

Revolutionen indenfor installation.
Uponor MLC Modulært Stigstrengssystem
MLC 63 - 110 mm

Nytænkning



Uponor MLC Stigstrengssystem MLC 63-110 mm – Modulsystemet, der klarer alle opgaver

Maksimal fleksibilitet med kun 27 dele

Uponor MLC stigstrengssystem 63 – 110 mm består af få komponenter, der alle er afstemt perfekt i forhold til hinanden. De dele, der er til rådighed dækker alle nødvendige størrelser, som er nødvendige for at opbygge et komplet stigstrengssystem

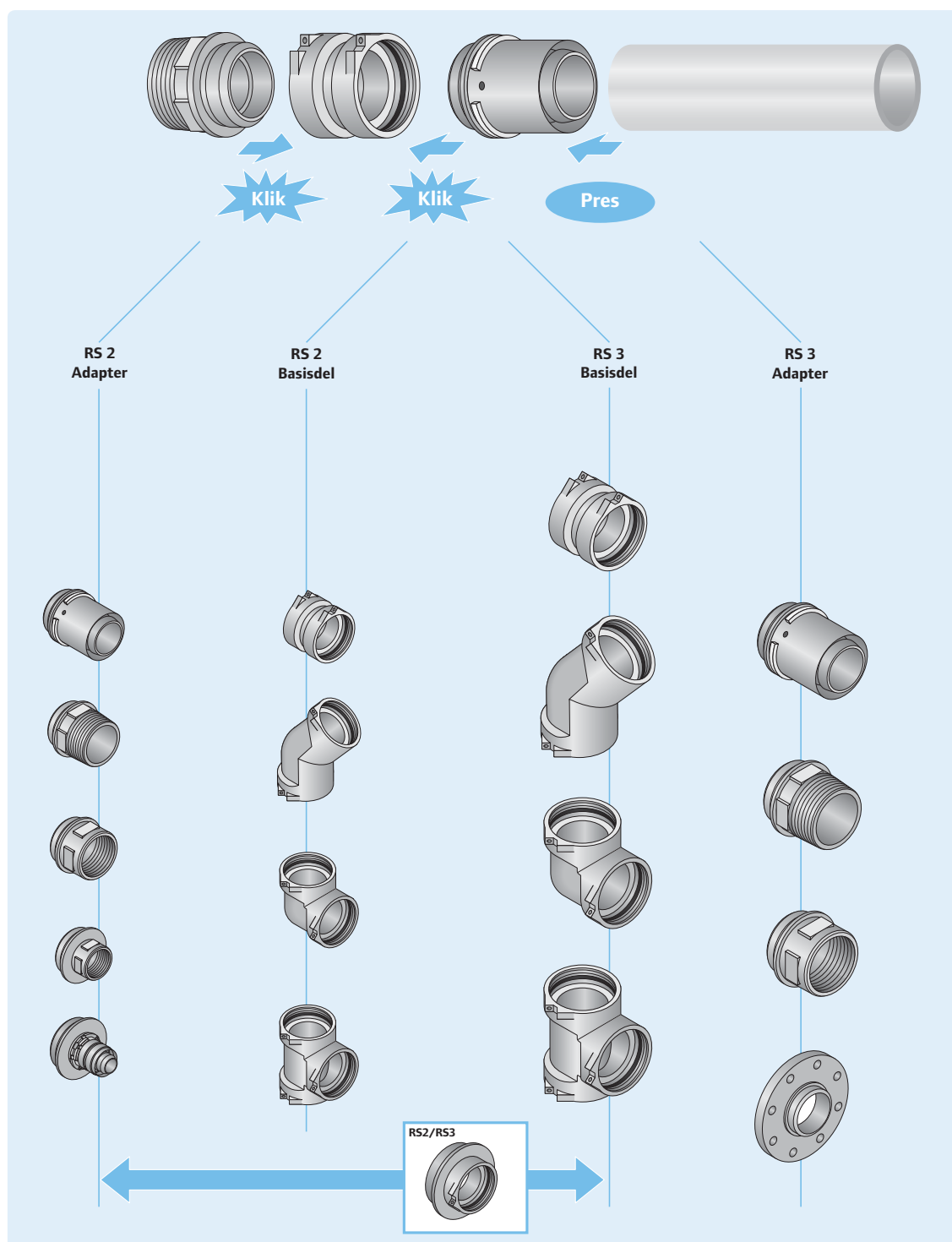

Det nye Uponor MLC Modulært Stigstrengssystem: Enkel montage, fleksibel planlægning og optimal indkøb

Enestående og innovativt stigstrengssystem revolutionerer installationsteknikken. Modulært fittingsystem med gennemprøvet presteknik for rørforbindelser op til Ø110 mm!

Det nye Uponor MLC Modulært Stigstrengssystem – Modulært design for alle tænkelige kombinationer:

- Kun 27 systemkomponenter muliggør hundredvis af variationer.
- Nyt koblingskoncept: Basisdele og dertil hørende adapterindsatse i forfinnet messing.
- Gennemprøvet presteknik for rørforbindelser.
- Ny type stikforbindelse mellem basisdel og adapter.
- Intet behov for ekstra værktøjer.
- Man kan bruge den velkendte Presmaskine UP 75 helt op til Ø 110 mm.



Uponor MLC Modulært Stigstrengssystem muliggør med kun 27 systemkomponenter alle mulige forbindelser og erstatter 300 fittings.



Basisdele og adapter muliggør alle tænkelige forbindelser.



Meget mere fleksibilitet med færre dele.



Sjældne forbindelsestyper udføres let med Uponor MLC Modulært Stigstrengssystem.

En procedure til alle opgaver

På grund af modulopbygningen består alle samlinger af de samme 5 trin. Presværktøjet bliver kun benyttet til pres og denne arbejdsgang kan derfor nemt foretages på arbejdsbordet. Det er ikke mere nødvendigt at stå i ubekvemme stillinger i hjørner med hænderne over hovedet for at få samlingerne færdiggjort.



Pres ganske enkelt det afgratede og kalibrerede Uponor MLC rør ind i presadapteren.



Pres.



Stik den forberedte rørforbindelse ind i basisdelen.



Selv på svært tilgængelige steder er monteringen nem.



Stik låsestiften ind i fittings.



Lås enden af låsestiften fast til fittings med et klik.

Kombinationsmulighederne gør systemet uovertruffen fleksibelt

Modulopbygningen giver altid en hurtig løsning. Uden lange leveringstider og ekstraomkostninger for specialdele.

Eksempler med T-stykke varianter

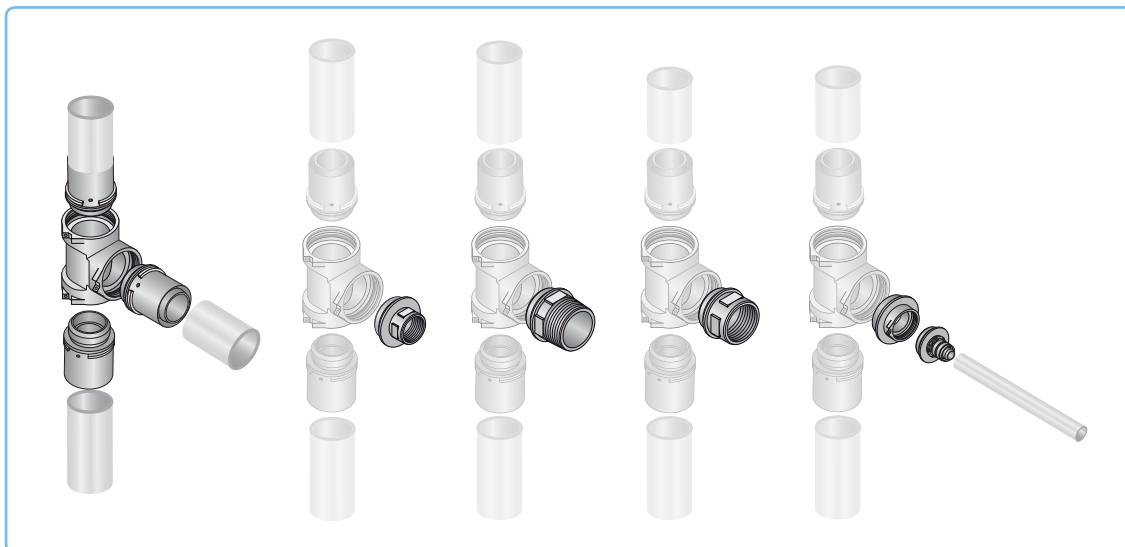

Eksempler med 45° bøjninger eller 90° vinkler



Eksempler med koblinger og reduceringer

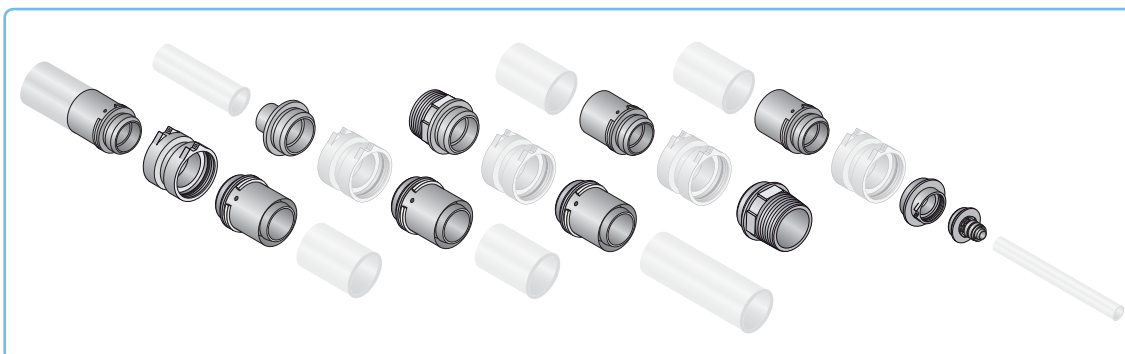



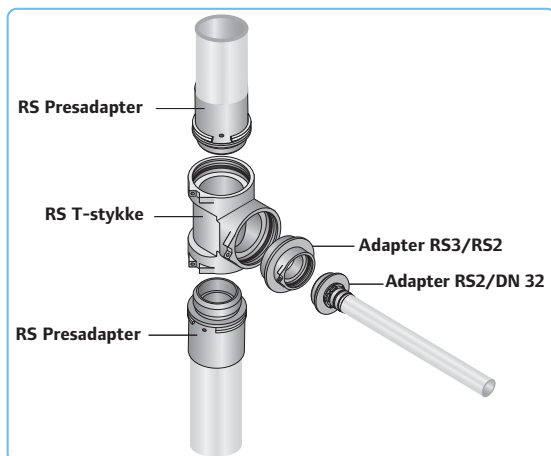

Eksempler

T-stykke med reduktion





Nødvendige dele til denne forbindelse

-  1 x Uponor RS T-Stykke
-  2 x Uponor RS Presadapter 40-110 MLC
-  1 x Uponor RS Kobling, reduktion
- 

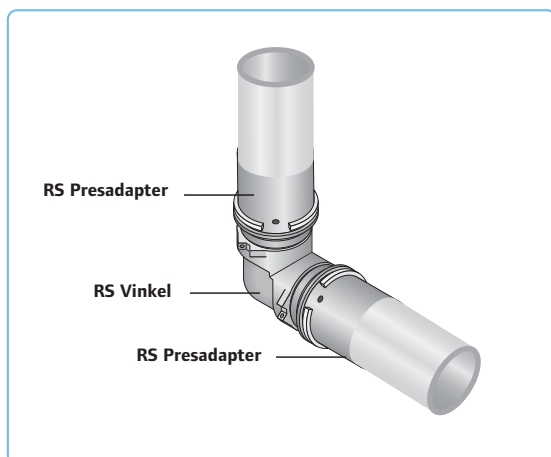
Uponor Pres-bøjning MLC





Nødvendige dele til denne forbindelse

-  1 x Uponor RS Vinkel 90°
-  2 x Uponor RS Presadapter 40-110 MLC

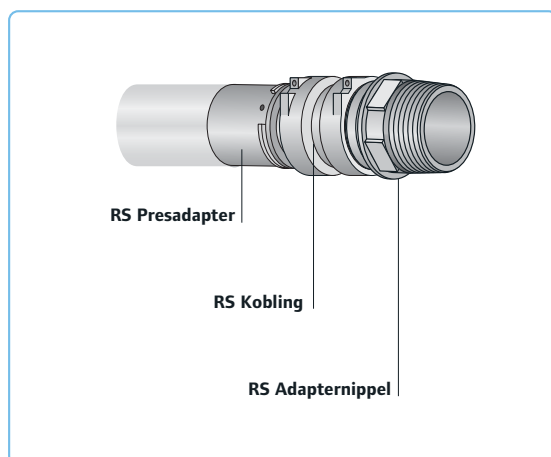
Uponor Pres-Reduktionsmuffe MLC



Nødvendige dele til denne forbindelse

-  1 x Uponor RS Kobling
-  1 Uponor RS Presadapter 40-110 MLC
-  1 Uponor RS Adapternippel

Kobling

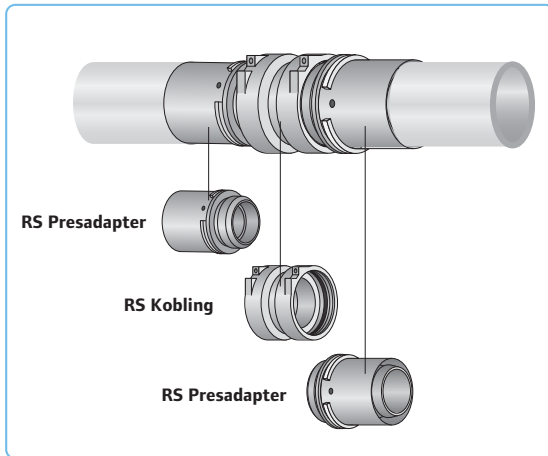



Nødvendige dele til denne forbindelse

-  1 x Uponor RS Kobling
-  2 x Uponor RS Presadapter

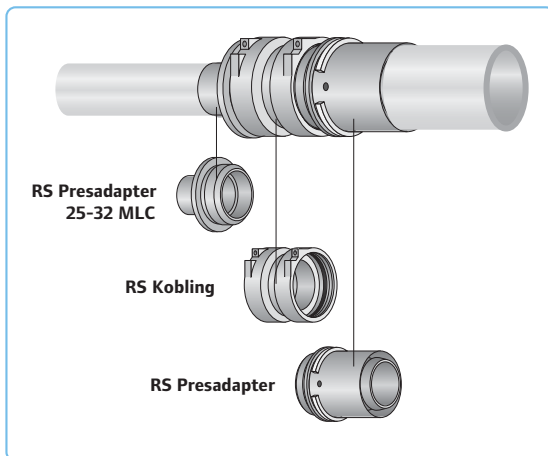
Kobling reduktion, 75-110



Nødvendige dele til denne forbindelse

-  1 x Uponor RS Kobling
-  1 x Uponor Presadapter
-  1 x RS Presadapter 25-32 MLC

Kobling reduktion, 110 - 25

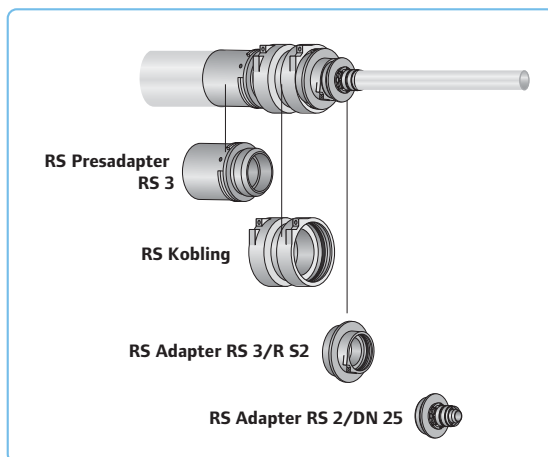









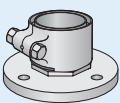

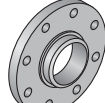
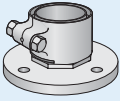

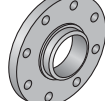
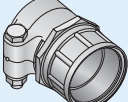



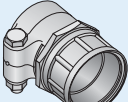

Nødvendige dele til denne forbindelse

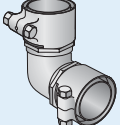
-  1 x Uponor RS Kobling
-  1 x Uponor Presadapter
-  1 x RS Presadapter 25-32 MLC
-  1 x RS Adapter RS3/RS2

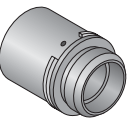
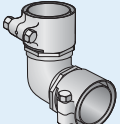

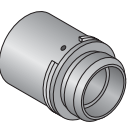
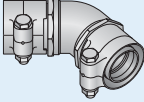
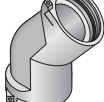







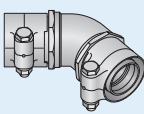

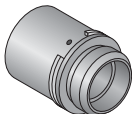
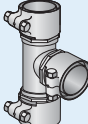

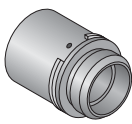
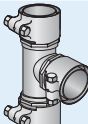

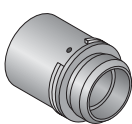
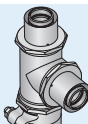
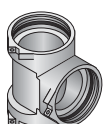
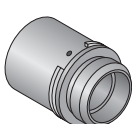
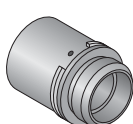
Konverteringsliste

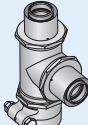
Uponor Presfittings MLC – Uponor Modulært Stigstrengssystem MLC

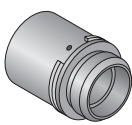
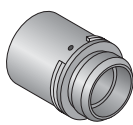
Gammel	Ny		
 <p>Art nr: 1014299 VVS nr: 04.5497.090</p> <p>Uponor Reduktionsflange MLC DN 80-90x8,5</p>	 <p>1029145 04.5456.114</p> <p>1 x Uponor RS Kobling RS 3</p>	 <p>1029127 04.5450.090</p> <p>1 x Uponor RS Presadapler RS 3/90</p>	 <p>1029129 04.5458.080</p> <p>1 x Uponor RS Flange RS 3/DN 80</p>
 <p>Art nr: 1014300 VVS nr: 04.5497.110</p> <p>Uponor Reduktionsflange MLC DN 100-110x10</p>	 <p>1029145 04.5456.114</p> <p>1 x Uponor RS Kobling RS 3</p>	 <p>1029128 04.5450.110</p> <p>1 x Uponor RS Presadapler RS 3/110</p>	 <p>1029130 04.5458.100</p> <p>1 x Uponor RS Flange RS 3/DN 100</p>
 <p>Art nr: 1014185 VVS nr: 04.5496.649</p> <p>Uponor Klemringskobling m/muffe MLC 90x3"</p>	 <p>1029145 04.5456.114</p> <p>1 x Uponor RS Kobling RS 3</p>	 <p>1029127 04.5450.090</p> <p>1 x Uponor RS Presadapler RS 3/90</p>	 <p>1029137 04.5452.114</p> <p>1 x Uponor RS adaptermuffe RS 3/Rp 3</p>
 <p>Art nr: 1014187 VVS nr: 04.5496.677</p> <p>Uponor Klemringskobling m/muffe MLC 110x3"</p>	 <p>1029145 04.5456.114</p> <p>1 x Uponor RS Kobling RS 3</p>	 <p>1029128 04.5450.110</p> <p>1 x Uponor RS Presadapler RS 3/110</p>	 <p>1029137 04.5452.114</p> <p>1 x Uponor RS adaptermuffe RS 3/Rp 3</p>
 <p>Art nr: 1014190 VVS nr: 04.5487.090</p> <p>Uponor Klemringsvinkel MLC 90-90</p>	 <p>1029139 04.5453.114</p> <p>1x Uponor RS Vinkel RS 3</p>	 <p>1029127 04.5450.090</p> <p>2 x Uponor RS Presadapler RS 3/90</p>	
 <p>Art nr: 1014191 VVS nr: 04.5487.110</p> <p>Uponor Klemringsvinkel MLC 110-110</p>	 <p>1029139 04.5453.114</p> <p>1x Uponor RS Vinkel RS 3</p>	 <p>1029128 04.5450.110</p> <p>2 x Uponor RS Presadapler RS 3/110</p>	
 <p>Art nr: 1014194 VVS nr: 04.5488.090</p> <p>Uponor Klemringsbøjning MLC 45Gr 90-9</p>	 <p>1029141 04.5454.114</p> <p>1 x Uponor RS Bøjning 45° RS 3</p>	 <p>1029127 04.5450.090</p> <p>2 x Uponor RS Presadapler RS 3/90</p>	

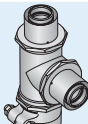
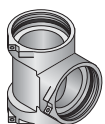
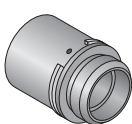
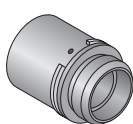

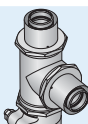
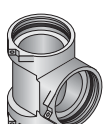
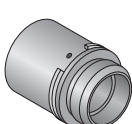
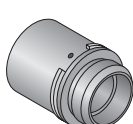
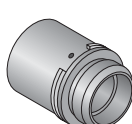
Konverteringsliste

Uponor Presfittings MLC – Uponor Modulært Stigstrengssystem MLC

Gammel	Ny				
 <p>Art nr: 1014195 VVS nr: 04.5488.110 Uponor Klemringsbøjning MLC 45Gr 110-110</p>	 <p>1029141 04.5454.114 1 x Uponor RS Bøjning 45° RS 3</p>	 <p>1029128 04.5450.110 2 x Uponor RS Presadapter RS 3/110</p>			
 <p>Art nr: 1014228 VVS nr: 04.5489.090 Uponor Klemrings-Tee 90-90-90</p>	 <p>1029143 04.5455.114 1 x Uponor RS T-stykke RS 3</p>	 <p>1029127 04.5450.090 3 x Uponor RS Presadapter RS 3/90</p>			
 <p>Art nr: 1014250 VVS nr: 04.5489.110 Uponor Klemrings-Tee MLC 110-110-110</p>	 <p>1029143 04.5455.114 1 x Uponor RS T-stykke RS 3</p>	 <p>1029128 04.5450.110 3 x Uponor RS Presadapter RS 3/110</p>			
 <p>Art nr: 1014234 VVS nr: 04.5490.689 Uponor Klemrings-Tee m/pres red. MLC 90-75-75</p>	 <p>1029143 04.5455.114 1 x Uponor RS T-stykke RS 3</p>	 <p>1029127 04.5450.090 1 x Uponor RS Presadapter RS 3/90</p>	 <p>1029126 04.5450.075 2 x Uponor RS Presadapter RS 2/75</p>	 <p>1029146 04.5456.180 2 x Uponor RS Kobling, reduceret RS 3/RS 2</p>	
 <p>Art nr: 1014230 VVS nr: 04.5490.648 Uponor Klemrings-Tee m/pres red. MLC 90-75-90</p>	 <p>1029143 04.5455.114 1 x Uponor RS T-stykke RS 3</p>	 <p>1029127 04.5450.090 2 x Uponor RS Presadapter RS 3/90</p>	 <p>1029126 04.5450.075 1 x Uponor RS Presadapter RS 2/75</p>	 <p>1029146 04.5456.180 1 x Uponor RS Kobling, reduceret RS 3/RS 2</p>	
 <p>Art nr: 1014233 VVS nr: 04.5490.690 Uponor Klemrings-Tee m/pres red. MLC 90-90-75</p>	 <p>1029143 04.5455.114 1 x Uponor RS T-stykke RS 3</p>	 <p>1029127 04.5450.090 2 x Uponor RS Presadapter RS 3/90</p>	 <p>1029126 04.5450.075 1 x Uponor RS Presadapter RS 2/75</p>	 <p>1029146 04.5456.180 1 x Uponor RS Kobling, reduceret RS 3/RS 2</p>	
 <p>Art nr: 1014237 VVS nr: 04.5490.691 Uponor Klemrings-Tee m/pres red. MLC 90-110-75</p>	 <p>1029143 04.5455.114 1 x Uponor RS T-stykke RS 3</p>	 <p>1029127 04.5450.090 1 x Uponor RS Presadapter RS 3/90</p>	 <p>1029128 04.5450.110 1 x Uponor RS Presadapter RS 3/110</p>	 <p>1029126 04.5450.075 1 x Uponor RS Presadapter RS 2/75</p>	 <p>1029146 04.5456.180 1 x Uponor RS Kobling, reduceret RS 3/RS 2</p>

Konverteringsliste

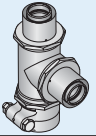
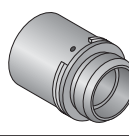
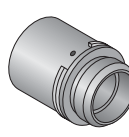
Uponor Presfittings MLC – Uponor Modulært Stigstrengssystem MLC

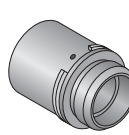
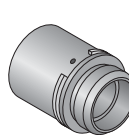
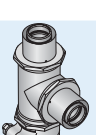
Gammel	Ny				
 <p>Art nr: 1014240 VVS nr: 04.5490.692</p> <p>Uponor Klemrings-Tee m/pres red. MLC 90-110-90</p>	 <p>1029143 04.5455.114</p> <p>1 x Uponor RS T-stykke RS 3</p>	 <p>1029127 04.5450.090</p> <p>2 x Uponor RS Presadapler RS 3/90</p>	 <p>1029128 04.5450.110</p> <p>1 x Uponor RS Presadapler RS 3/110</p>		
 <p>Art nr: 1014262 VVS nr: 04.5490.705</p> <p>Uponor Klemrings-Tee m/pres red. MLC 110-75-75</p>	 <p>1029143 04.5455.114</p> <p>1 x Uponor RS T-stykke RS 3</p>	 <p>1029128 04.5450.110</p> <p>1 x Uponor RS Presadapler RS 3/110</p>	 <p>1029126 04.5450.075</p> <p>2 x Uponor RS Presadapler RS 2/75</p>	 <p>1029146 04.5456.180</p> <p>2 x Uponor RS Kobling, reduceret RS 3/RS 2</p>	
 <p>Art nr: 1014268 VVS nr: 04.5490.706</p> <p>Uponor Klemrings-Tee m/pres red. MLC 110-75-90</p>	 <p>1029143 04.5455.114</p> <p>1 x Uponor RS T-stykke RS 3</p>	 <p>1029128 04.5450.110</p> <p>1 x Uponor RS Presadapler RS 3/110</p>	 <p>1029126 04.5450.075</p> <p>1 x Uponor RS Presadapler RS 2/75</p>	 <p>1029127 04.5450.090</p> <p>1 x Uponor RS Presadapler RS 3/90</p>	 <p>1029146 04.5456.180</p> <p>1 x Uponor RS Kobling, reduceret RS 3/RS 2</p>
 <p>Art nr: 1014254 VVS nr: 04.5490.676</p> <p>Uponor Klemrings-Tee m/pres red. MLC 110-75-110</p>	 <p>1029143 04.5455.114</p> <p>1 x Uponor RS T-stykke RS 3</p>	 <p>1029128 04.5450.110</p> <p>2 x Uponor RS Presadapler RS 3/110</p>	 <p>1029126 04.5450.075</p> <p>1 x Uponor RS Presadapler RS 2/75</p>	 <p>1029146 04.5456.180</p> <p>1 x Uponor RS Kobling, reduceret RS 3/RS 2</p>	
 <p>Art nr: 1014267 VVS nr: 04.5490.707</p> <p>Uponor Klemrings-Tee m/pres red. MLC 110-90-75</p>	 <p>1029143 04.5455.114</p> <p>1 x Uponor RS T-stykke RS 3</p>	 <p>1029128 04.5450.110</p> <p>1 x Uponor RS Presadapler RS 3/110</p>	 <p>1029127 04.5450.090</p> <p>1 x Uponor RS Presadapler RS 3/90</p>	 <p>1029126 04.5450.075</p> <p>1 x Uponor RS Presadapler RS 2/75</p>	 <p>1029146 04.5456.180</p> <p>1 x Uponor RS Kobling, reduceret RS 3/RS 2</p>
 <p>Art nr: 1014266 VVS nr: 04.5490.708</p> <p>Uponor Klemrings-Tee m/pres red. MLC 110-90-90</p>	 <p>1029143 04.5455.114</p> <p>1 x Uponor RS T-stykke RS 3</p>	 <p>1029128 04.5450.110</p> <p>1 x Uponor RS Presadapler RS 3/110</p>	 <p>1029127 04.5450.090</p> <p>2 x Uponor RS Presadapler RS 3/90</p>		
 <p>Art nr: 1014257 VVS nr: 04.5490.679</p> <p>Uponor Pres-T-stykke red. MLC 110-90-110</p>	 <p>1029143 04.5455.114</p> <p>1 x Uponor RS T-stykke RS 3</p>	 <p>1029128 04.5450.110</p> <p>2x Uponor RS Presadapler RS 3/110</p>	 <p>1029127 04.5450.090</p> <p>1 x Uponor RS Presadapler RS 3/90</p>		





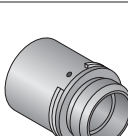



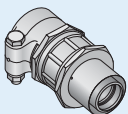

Konverteringsliste

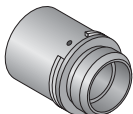
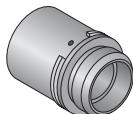
Uponor Presfittings MLC – Uponor Modulært Stigstrengssystem MLC

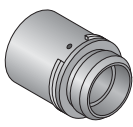
Gammel	Ny			
 <p>Art nr: 1014259 VVS nr: 04.5490.709</p> <p>Uponor Klemrings-Tee m/pres red. MLC 110-110-75</p>	 <p>1029143 04.5455.114</p> <p>1 x Uponor RS T-stykke RS 3</p>	 <p>1029128 04.5450.110</p> <p>2 x Uponor RS Presadapter RS 3/110</p>	 <p>1029126 04.5450.075</p> <p>1 x Uponor RS Presadapter RS 2/75</p>	 <p>1029146 04.5456.180</p> <p>1 x Uponor RS Kobling, reduceret RS 3/RS 2</p>
 <p>Art nr: 1014264 VVS nr: 04.5490.710</p> <p>Uponor Klemrings-Tee m/pres red. MLC 110-110-90</p>	 <p>1029143 04.5455.114</p> <p>1 x Uponor RS T-stykke RS 3</p>	 <p>1029128 04.5450.110</p> <p>2 x Uponor RS Presadapter RS 3/110</p>	 <p>1029127 04.5450.090</p> <p>1 x Uponor RS Presadapter RS 3/90</p>	
 <p>Art nr: 1014301 VVS nr: 04.5492.649</p> <p>Uponor Klemrings-Tee m/muffe MLC 90-Rp3-90</p>	 <p>1029143 04.5455.114</p> <p>1 x Uponor RS T-stykke RS 3</p>	 <p>1029127 04.5450.090</p> <p>2 x Uponor RS Presadapter RS 3/90</p>	 <p>1029137 04.5452.114</p> <p>1 x Uponor RS adaptermuffe RS 3/Rp 3</p>	
 <p>Art nr: 1014302 VVS nr: 04.5492.677</p> <p>Uponor Klemrings-Tee m/muffe MLC 110-Rp3-110</p>	 <p>1029143 04.5455.114</p> <p>1 x Uponor RS T-stykke RS 3</p>	 <p>1029128 04.5450.110</p> <p>2 x Uponor RS Presadapter RS 3/110</p>	 <p>1029137 04.5452.114</p> <p>1 x Uponor RS adaptermuffe RS 3/Rp 3</p>	
 <p>Art nr: 1014286 VVS nr: 04.5493.090</p> <p>Uponor Klemringsmuffe MLC 90-90</p>	 <p>1029145 04.5456.114</p> <p>1 x Uponor RS Kobling RS 3</p>	 <p>1029127 04.5450.090</p> <p>2 x Uponor RS Presadapter RS 3/90</p>		
 <p>Art nr: 1014288 VVS nr: 04.5493.110</p> <p>Uponor Klemringsmuffe MLC 110-110</p>	 <p>1029145 04.5456.114</p> <p>1 x Uponor RS Kobling RS 3</p>	 <p>1029128 04.5450.110</p> <p>2 x Uponor RS Presadapter RS 3/110</p>		
 <p>Art nr: 1014287 VVS nr: 04.5494.648</p> <p>Uponor Klemringsmuffe red. MLC 90-75</p>	 <p>1029145 04.5456.114</p> <p>1 x Uponor RS Kobling RS 3</p>	 <p>1029127 04.5450.090</p> <p>1 x Uponor RS Presadapter RS 3/90</p>	 <p>1029126 04.5450.075</p> <p>1 x Uponor RS Presadapter RS 2/75</p>	 <p>1029146 04.5456.180</p> <p>1 x Uponor RS Kobling, reduceret RS 3/RS 2</p>

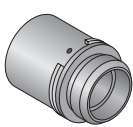

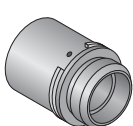

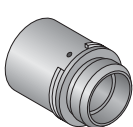
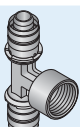
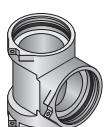
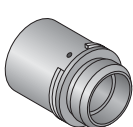
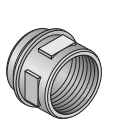
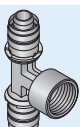
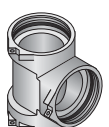
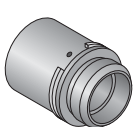
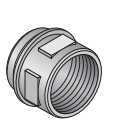







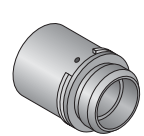

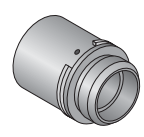
Konverteringsliste

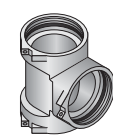
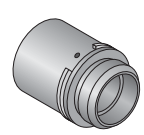
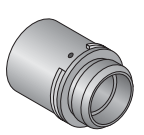
Uponor Presfittings MLC – Uponor Modulært Stigstrengssystem MLC

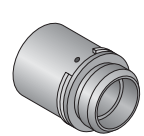
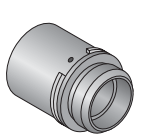
Gammel	Ny		
 <p>Art nr: 1014289 VVS nr: 04.5494.679</p> <p>Uponor Klemringsmuffe red. MLC 110-90</p>	 <p>1029145 04.5456.114</p> <p>1 x Uponor RS Kobling RS 3</p>	 <p>1029128 04.5450.110</p> <p>1 x Uponor RS Presadapter RS 3/110</p>	 <p>1029127 04.5450.090</p> <p>1 x Uponor RS Presadapter RS 3/90</p>
 <p>Art nr: 1014189 VVS nr: 04.5470.175</p> <p>Uponor Pres-vinkel MLC 75-75</p>	 <p>1029138 04.5453.112</p> <p>1 x Uponor RS Vinkel RS 2</p>	 <p>1029126 04.5450.075</p> <p>2 x Uponor RS Presadapter RS 2/75</p>	
 <p>Art nr: 1014188 VVS nr: 04.5470.163</p> <p>Uponor Pres-vinkel MLC 63-63</p>	 <p>1029138 04.5453.112</p> <p>1 x Uponor RS Vinkel RS 2</p>	 <p>1029125 04.5450.063</p> <p>2 x Uponor RS Presadapter RS 2/63</p>	
 <p>Art nr: 1014193 VVS nr: 04.5473.175</p> <p>Uponor Pres-bøjning MLC 45Gr 75-75</p>	 <p>1029140 04.5454.112</p> <p>1 x Uponor RS Bøjning 45° RS 2</p>	 <p>1029126 04.5450.075</p> <p>2 x Uponor RS Presadapter RS 2/75</p>	
 <p>Art nr: 1014192 VVS nr: 04.5473.063</p> <p>Uponor Pres-bøjning MLC 45Gr 63-63</p>	 <p>1029140 04.5454.112</p> <p>1 x Uponor RS Bøjning 45° RS 2</p>	 <p>1029125 04.5450.063</p> <p>2 x Uponor RS Presadapter RS 2/63</p>	
 <p>Art nr: 1014214 VVS nr: 04.5478.610</p> <p>Uponor Pres-T-stykke MLC 75-Rp1-75</p>	 <p>1029142 04.5455.112</p> <p>1 x Uponor RS T-stykke RS 2</p>	 <p>1029126 04.5450.075</p> <p>2 x Uponor RS Presadapter RS 2/75</p>	 <p>1029134 04.5452.165</p> <p>1 x Uponor RS adaptermuffe RS 2/Rp 1</p>
 <p>Art nr: 1014205 VVS nr: 04.5478.462</p> <p>Uponor Pres-T-stykke MLC 63-Rp1-63</p>	 <p>1029142 04.5455.112</p> <p>1 x Uponor RS T-stykke RS 2</p>	 <p>1029125 04.5450.063</p> <p>2 x Uponor RS Presadapter RS 2/63</p>	 <p>1029134 04.5452.165</p> <p>1 x Uponor RS adaptermuffe RS 2/Rp 1</p>

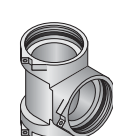
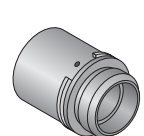
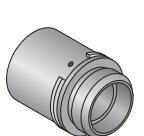

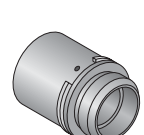
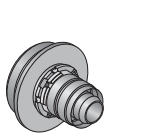
Konverteringsliste

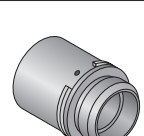
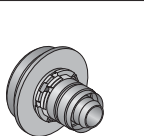
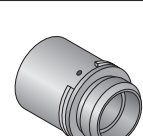
Uponor Presfittings MLC – Uponor Modulært Stigstrengssystem MLC

Gammel	Ny			
 <p>Art nr: 1014211 VVS nr: 04.5476.175 Uponor Pres-T-stykke MLC 75-75-75</p>	 <p>1029142 04.5455.112 1 x Uponor RS T-stykke RS 2</p>	 <p>1029126 04.5450.075 3 x Uponor RS Presadapter RS 2/75</p>		
 <p>Art nr: 1011498 VVS nr: 04.5476.063 Uponor Pres-T-stykke MLC 63-63-63</p>	 <p>1029142 04.5455.112 1 x Uponor RS T-stykke RS 2</p>	 <p>1029125 04.5450.063 3 x Uponor RS Presadapter RS 2/63</p>		
 <p>Art nr: 1014212 VVS nr: 04.5476.616 Uponor Pres-T-stykke red. MLC 75-50-75</p>	 <p>1029142 04.5455.112 1 x Uponor RS T-stykke RS 2</p>	 <p>1029126 04.5450.075 2 x Uponor RS Presadapter RS 2/75</p>	 <p>1029124 04.5450.050 1 x Uponor RS Presadapter RS 2/50</p>	
 <p>Art nr: 1014213 VVS nr: 04.5476.614 Uponor Pres-T-stykke red. MLC 75-40-75</p>	 <p>1029142 04.5455.112 1 x Uponor RS T-stykke RS 2</p>	 <p>1029126 04.5450.075 2 x Uponor RS Presadapter RS 2/75</p>	 <p>1029123 04.5450.040 1 x Uponor RS Presadapter RS 2/40</p>	
 <p>Art nr: 1014199 VVS nr: 04.5476.464 Uponor Pres-T-stykke red. MLC 63-40-63</p>	 <p>1029142 04.5455.112 1 x Uponor RS T-stykke RS 2</p>	 <p>1029125 04.5450.063 2 x Uponor RS Presadapter RS 2/63</p>	 <p>1029123 04.5450.040 1 x Uponor RS Presadapter RS 2/40</p>	
 <p>Art nr: 1014201 VVS nr: 04.5476.463 Uponor Pres-T-stykke red. MLC 63-32-63</p>	 <p>1029142 04.5455.112 1 x Uponor RS T-stykke RS 2</p>	 <p>1029125 04.5450.063 2 x Uponor RS Presadapter RS 2/63</p>	 <p>1029122 04.5450.032 1 x Uponor RS Presadapter RS 2/32</p>	
 <p>Art nr: 1014216 VVS nr: 04.5476.609 Uponor Pres-T-stykke red. MLC 75-25-63</p>	 <p>1029142 04.5455.112 1 x Uponor RS T-stykke RS 2</p>	 <p>1029126 04.5450.075 1 x Uponor RS Presadapter RS 2/75</p>	 <p>1029121 04.5450.025 1 x Uponor RS Presadapter RS 2/25</p>	 <p>1029125 04.5450.063 1 x Uponor RS Presadapter RS 2/63</p>

Konverteringsliste

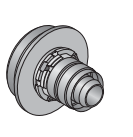
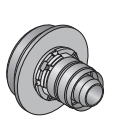
Uponor Presfittings MLC – Uponor Modulært Stigstrengssystem MLC

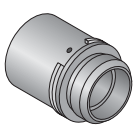
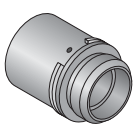
Gammel	Ny			
 <p>Art nr: 1014200 VVS nr: 04.5476.462 Uponor Pres-T-stykke red. MLC 63-25-63</p>	 <p>1029142 04.5455.112 1 x Uponor RS T-stykke RS 2</p>	 <p>1029125 04.5450.063 2 x Uponor RS Presadapter RS 2/63</p>	 <p>1029121 04.5450.025 1 x Uponor RS Presadapter RS 2/25</p>	
 <p>Art nr: 1014203 VVS nr: 04.5476.461 Uponor Pres-T-stykke red. MLC 63-25-50</p>	 <p>1029142 04.5455.112 1 x Uponor RS T-stykke RS 2</p>	 <p>1029125 04.5450.063 1 x Uponor RS Presadapter RS 2/63</p>	 <p>1029121 04.5450.025 1 x Uponor RS Presadapter RS 2/25</p>	 <p>1029124 04.5450.050 1 x Uponor RS Presadapter RS 2/50</p>
 <p>Art nr: 1014282 VVS nr: 04.5480.175 Uponor Pres-muffe MLC 75-75</p>	 <p>1029144 04.5456.112 1 x Uponor RS Kobling RS 2</p>	 <p>1029126 04.5450.075 2 x Uponor RS Presadapter RS 2/75</p>		
 <p>Art nr: 1014271 VVS nr: 04.5480.063 Uponor Pres-muffe MLC 63-63</p>	 <p>1029144 04.5456.112 1 x Uponor RS Kobling RS 2</p>	 <p>1029125 04.5450.063 2 x Uponor RS Presadapter RS 2/63</p>		
 <p>Art nr: 1014283 VVS nr: 04.5480.618 Uponor Pres-muffe red. MLC 75-63</p>	 <p>1029144 04.5456.112 1 x Uponor RS Kobling RS 2</p>	 <p>1029126 04.5450.075 1 x Uponor RS Presadapter RS 2/75</p>	 <p>1029125 04.5450.063 1 x Uponor RS Presadapter RS 2/63</p>	
 <p>Art nr: 1014284 VVS nr: 04.5480.616 Uponor Pres-muffe red. MLC 75-50</p>	 <p>1029144 04.5456.112 1 x Uponor RS Kobling RS 2</p>	 <p>1029126 04.5450.075 1 x Uponor RS Presadapter RS 2/75</p>	 <p>1029124 04.5450.050 1 x Uponor RS Presadapter RS 2/50</p>	
 <p>Art nr: 1014275 VVS nr: 04.5480.465 Uponor Pres-muffe red. MLC 63-50</p>	 <p>1029144 04.5456.112 1 x Uponor RS Kobling RS 2</p>	 <p>1029125 04.5450.063 1 x Uponor RS Presadapter RS 2/63</p>	 <p>1029124 04.5450.050 1 x Uponor RS Presadapter RS 2/50</p>	

Konverteringsliste

Uponor Presfittings MLC – Uponor Modulært Stigstrengssystem MLC

Gammel	Ny		
 <p>Art nr: 1014285 VVS nr: 04.5480.614 Uponor Pres-muffe red. MLC 75-40</p>	 <p>1029144 04.5456.112 1 x Uponor RS Kobling RS 2</p>	 <p>1029126 04.5450.075 1 x Uponor RS Presadapter RS 2/75</p>	 <p>1029123 04.5450.040 1 x Uponor RS Presadapter RS 2/40</p>
 <p>Art nr: 1014279 VVS nr: 04.5480.464 Uponor Pres-muffe red. MLC 63-40</p>	 <p>1029144 04.5456.112 1 x Uponor RS Kobling RS 2</p>	 <p>1029125 04.5450.063 1 x Uponor RS Presadapter RS 2/63</p>	 <p>1029123 04.5450.040 1 x Uponor RS Presadapter RS 2/40</p>
 <p>Art nr: 1014182 VVS nr: 04.5482.618 Uponor Pres-reduktionsmuffe MLC 75-Rp2½</p>	 <p>1029144 04.5456.112 1 x Uponor RS Kobling RS 2</p>	 <p>1029126 04.5450.075 1 x Uponor RS Presadapter RS 2/75</p>	 <p>1029136 04.5452.167 1 x Uponor RS adaptermuffe RS 2/Rp 2½</p>
 <p>Art nr: 1014178 VVS nr: 04.5482.467 Uponor Pres-reduktionsmuffe MLC 63-Rp2</p>	 <p>1029144 04.5456.112 1 x Uponor RS Kobling RS 2</p>	 <p>1029125 04.5450.063 1 x Uponor RS Presadapter RS 2/63</p>	 <p>1029135 04.5452.112 1 x Uponor RS adaptermuffe RS 2/Rp 2</p>
 <p>Art nr: 1014180 VVS nr: 04.5481.618 Uponor Pres-reduktionsnippel MLC 75-R2</p>	 <p>1029144 04.5456.112 1 x Uponor RS Kobling RS 2</p>	 <p>1029126 04.5450.075 1 x Uponor RS Presadapter RS 2/75</p>	 <p>1029132 04.5451.167 1 x Uponor RS adapternippel RS 2/Rp 2</p>
 <p>Art nr: 1014174 VVS nr: 04.5481.467 Uponor Pres-reduktionsnippel MLC 63-R2</p>	 <p>1029144 04.5456.112 1 x Uponor RS Kobling RS 2</p>	 <p>1029125 04.5450.063 1 x Uponor RS Presadapter RS 2/63</p>	 <p>1029131 04.5451.112 1 x Uponor RS adapternippel RS 2/R 2</p>

Uponor A/S
Uponor VVS
Banemarksvej 2 A
2600 Glostrup

T 43 26 34 00
F 43 43 10 11
F 43 26 34 84, teknisk service
W www.uponor.dk

uponor