

# Heat-only Thermostat with Touchscreen

## technical bulletin

### Affected product

Heat-only Thermostat with Touchscreen (A3100101)

### Issue

Uponor designed the thermostat for simple installation using two wires. The connection is not polarity sensitive, so any wiring combination will work. However, incompatibility with certain third-party devices (e.g., relay panels) may require a bypass resistor.

**Note:** During the development process, Uponor performed comprehensive testing on most common devices. At that time, only Caleffi panels required the bypass resistor. However, recent findings reveal the Taco EXP panels may require the bypass resistor as well.

### How to identify

The relay buzzes or there is a constant call for heating that will not go away.

### Cause

Due to the thermostat's power-stealing design, it is "leaking" a minimal amount of current through the thermostat. Depending on the rating or sensitivity of the relay coil, this could be enough current to start a call for heating, but not hold it (hence, the buzzing), or bring it on constantly with no call for heating.

### Resolution

Wire in the bypass resistor as shown in **Figure 1**.

**Note:** Check the packaging for an incorrect resistor. Uponor's specification is for a 1,000 Ohm resistor. However, there have been 10,000 Ohm resistors in some packaging. The color coding is very close between the values and could also be the cause for the error. In repeating compatibility testing, the 10,000 Ohm resistor works half the time. Refer to **Figure 2** for the correct color code.

If the relay buzzing remains after installing the correct resistor, return the thermostat through Uponor's Return Material Authorization (RMA) process for replacement.

For further assistance, contact Uponor Technical Services at 888.594.7726 (U.S.) or 888.994.7726 (Canada).

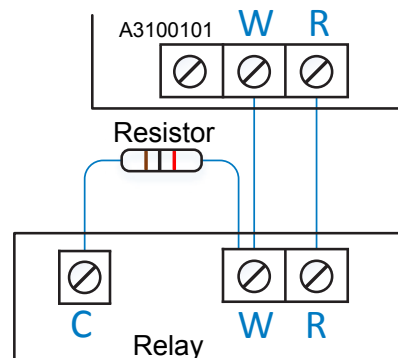

**Figure 1:** Bypass resistor wiring

1K resistor (correct)



10K resistor (incorrect)



**Figure 2:** Correct color code

**Uponor Inc.**  
5925 148th Street West  
Apple Valley, MN 55124  
USA

T 800.321.4739  
F 952.891.2008

**Uponor Ltd.**  
6510 Kennedy Road  
Mississauga, ON L5T 2X4  
CANADA

T 888.994.7726  
F 800.638.9517