

Uponor sistem ometa za stropno in stensko hlajenje/ogrevanje

MONTAŽNA NAVODILA

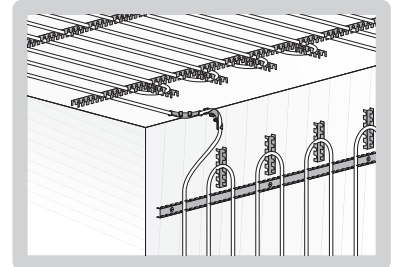

Vgradnjo lahko izvede le pooblaščen izvajalec!



Vgradnja cevnega sistema

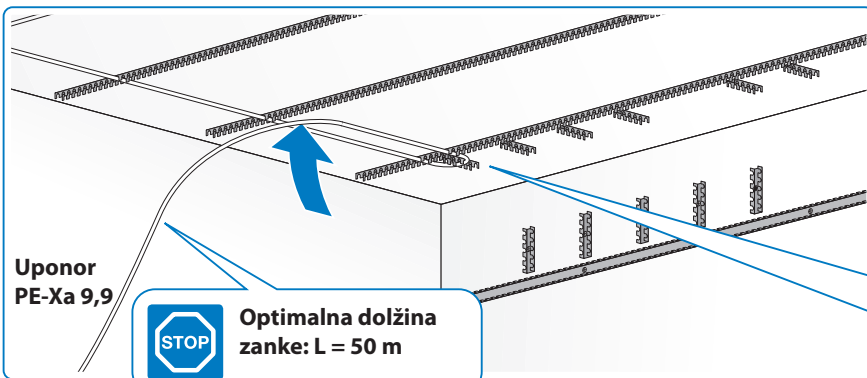
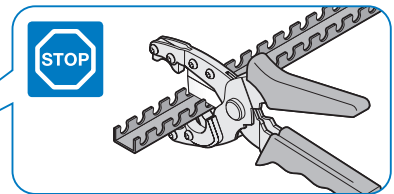
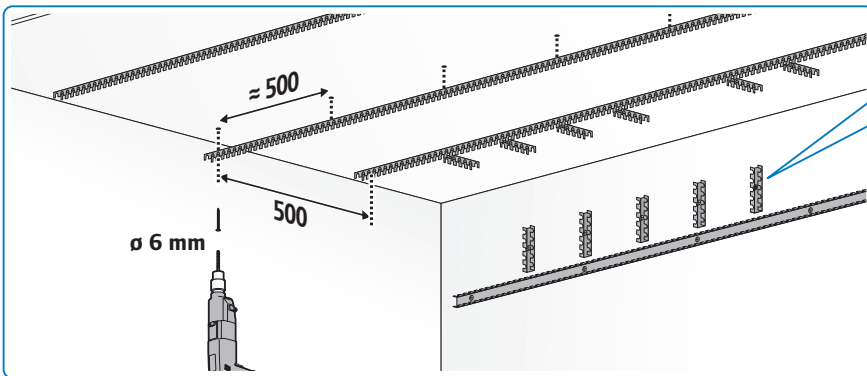

T	a
80	60
100	70
140	90

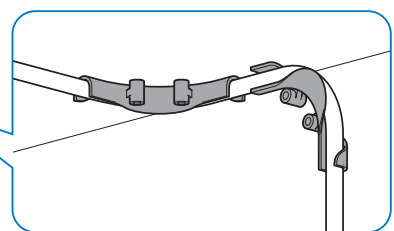
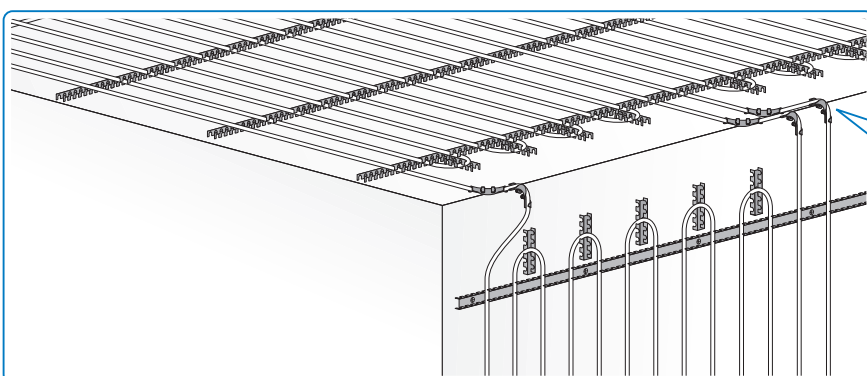

Uponor
PE-Xa 9,9



Optimalna dolžina
zanke: L = 50 m

Vgradnja dovodnih cevi



Sledite dodatnim navodilom:
Uponor Q&E instalacija/montaža

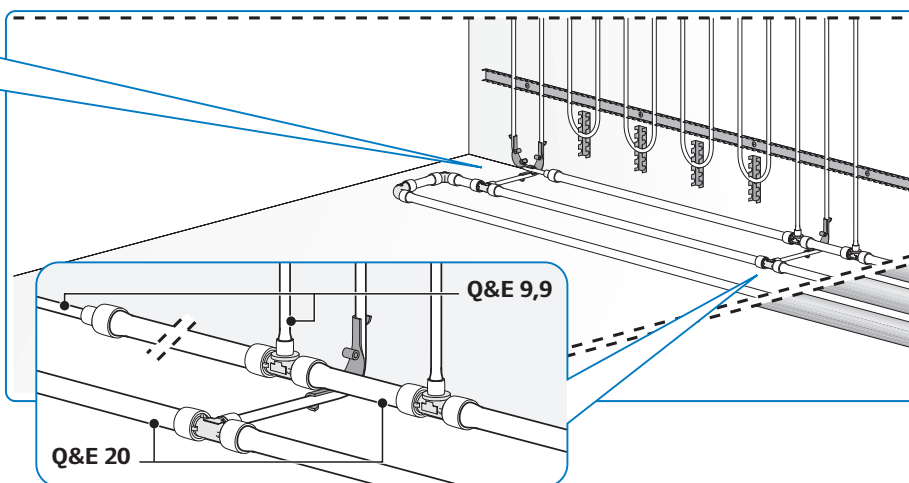
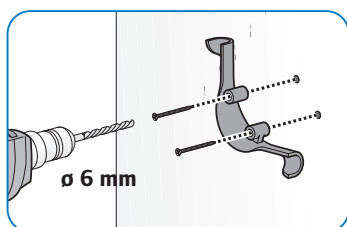
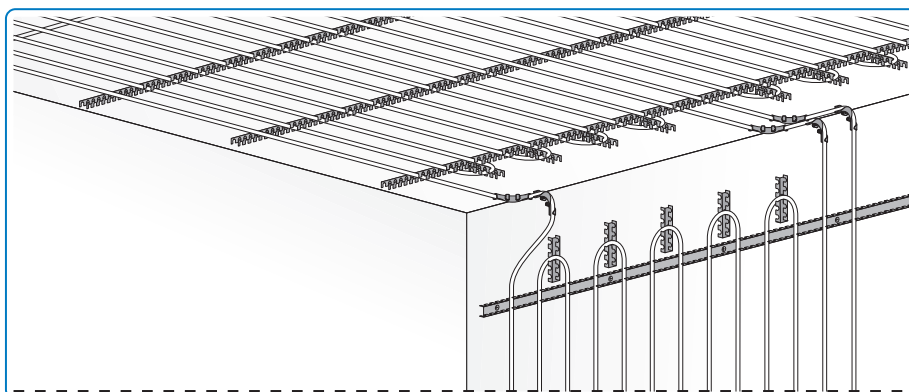

Polnjenje cevne sistema/tlačni preizkus

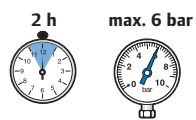
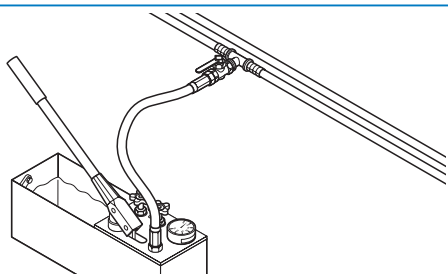

Po 2 urah preizkus tesnosti



DIN 1264-4



Montažna/obratovalna navodila
za Uponor razdelilce



Izdelava ometa

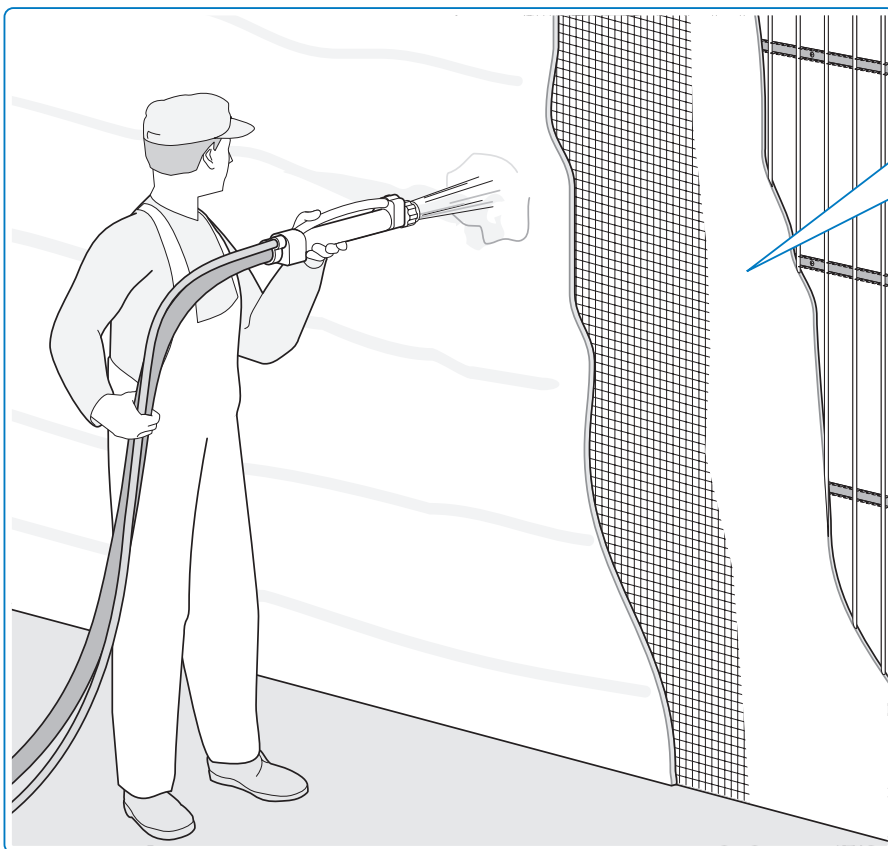

npr. Knauf MP75 G/F-Light

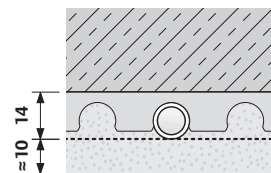

npr. Knauf MP75 Diamant

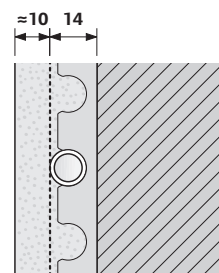

Med ometavanjem morajo biti vsi krogotoki obremenjeni z obratovalnim tlakom. Sistem mora biti zaščiten proti zmrzali.

Preizkus obratovanja

Delovanje sistema mora biti preizkušeno s funkcionalnim ogrevanjem. Za dokumentacijo uporabite Uponorjev formular za funkcionalno ogrevanje.

Čakalna doba, po izdelavi ometa, mora biti:

- Omet na osnovi cementa: > 21 dni
- Omet na osnovi gipsa: > 7 dni

Upoštevati je potrebno navodila proizvajalca ometov.

Obratovanje

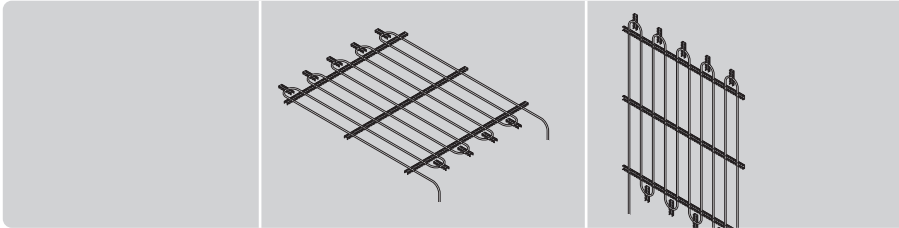

Ø dovoda

16 – 40° C

16 – 50° C

Ø površine

< 35° C

< 40° C

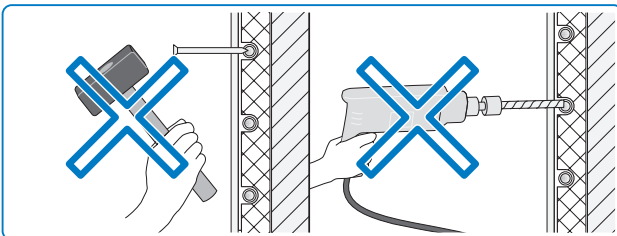

Upravnik zgradbe mora biti obveščen o položaju cevi in celotnega sistema.

Uponor GmbH
International Sales
P.O. Box 1641
97433 Hassfurt
Germany
T +49-(0)9521 690 783
F +49-(0)9521 690 750
E international@uponor.com
W www.uponor.si

TITAN d.d.
Kovinarska 28
SI-1241 Kamnik
Slovenija
T (01) 8309 170 prodaja
(01) 8309 169
(01) 8309 168 tehnična služba
F (01) 8309 171
E pc5@titan.si
W www.titan.si

Uponor
simply more

