

© Copyright Uponor Limited

Copyright in this drawing belongs to Uponor Limited. This drawing may not be used, sold, licensed, transferred, copied or reproduced in whole or in part or in any manner or form other than with the prior written consent of Uponor Limited.



Mechanical Schematic

PPG Pump Set

Ref: PPG-1.0A

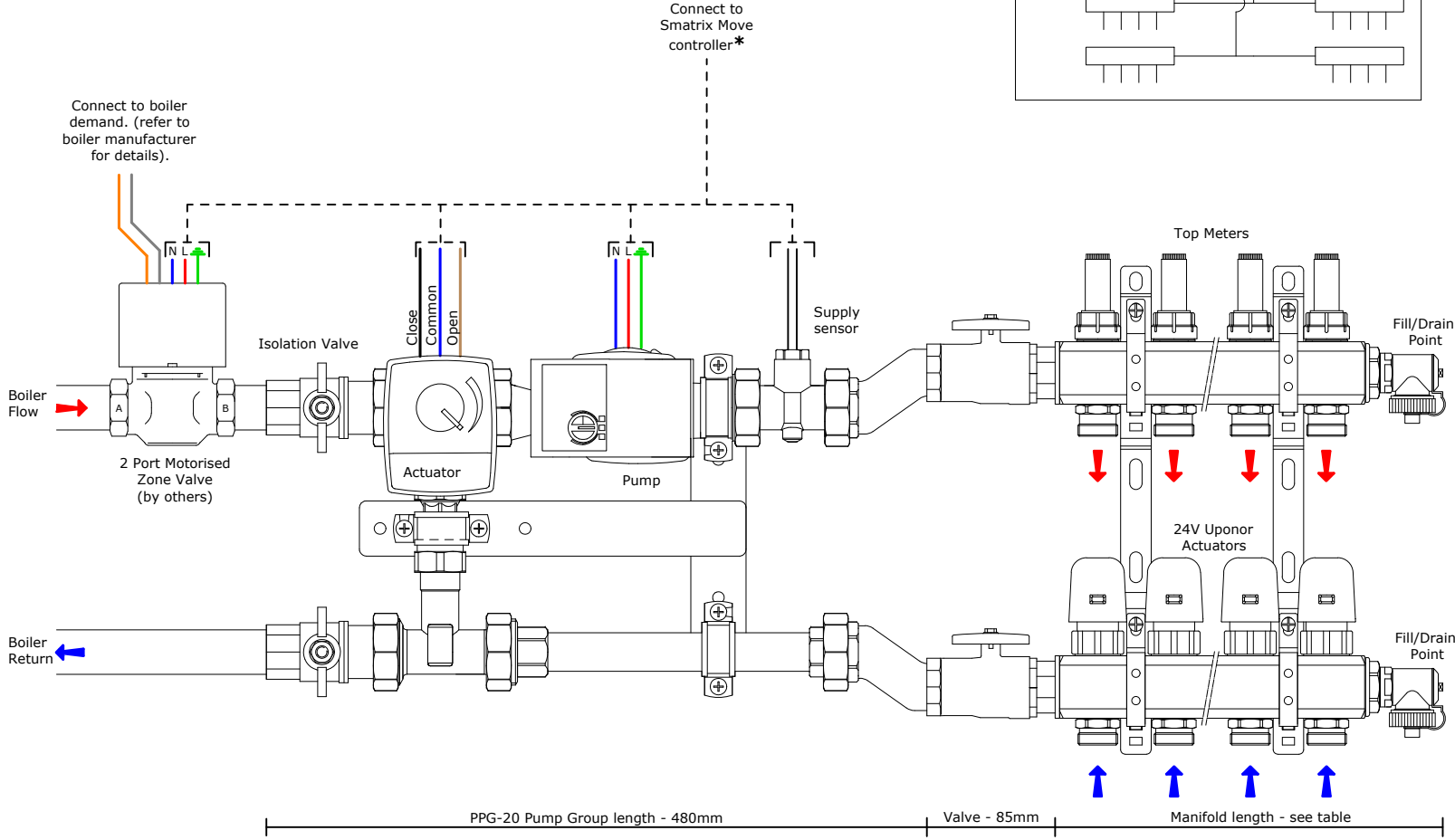
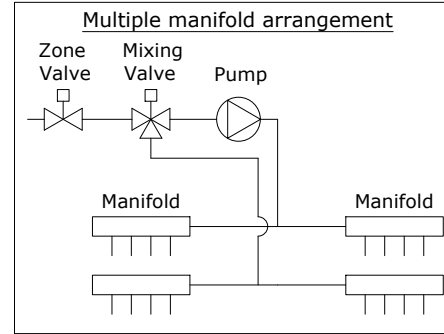

* Refer to Smatrix Move electrical schematic for connections.

Manifold	Length
2 Port	147mm
3 Port	197mm
4 Port	247mm
5 Port	297mm
6 Port	347mm
7 Port	397mm
8 Port	447mm
9 Port	497mm
10 Port	547mm
11 Port	597mm
12 Port	647mm

The height of the manifold is 340mm and needs to be mounted at least 300mm from the floor.

Notes,

- 1) A bypass is recommended on the primary circuit.
- 2) The drawing excludes isolating & regulating valves for clarity.
- 3) All items to be installed in accordance with manufacturer's instructions and current best practices.
- 4) If limited space is available the manifold and pump set may be split and installed in different locations to save space.

Uponor reserve the right to alter specifications and operating parameters for all their systems at any time as part of their policy of continuous product development.