

Mounting instructions

Uponor Metallic Pipe PLUS 16 – 20 mm

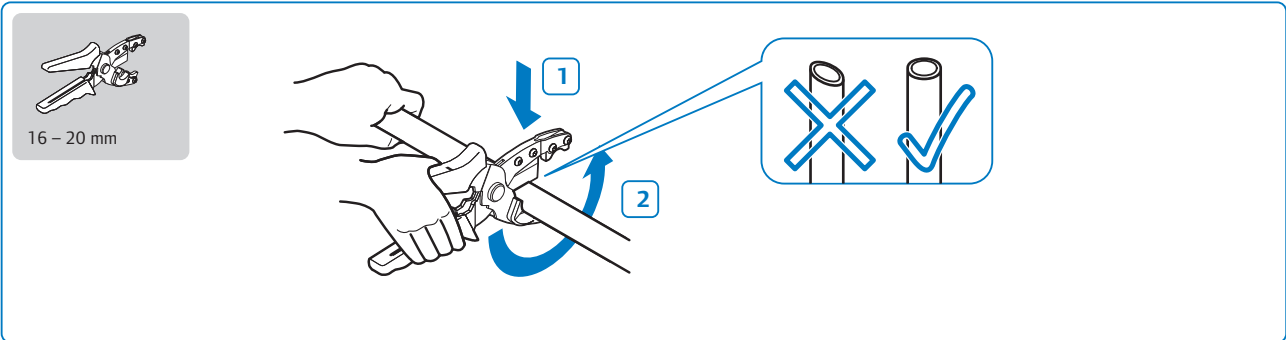

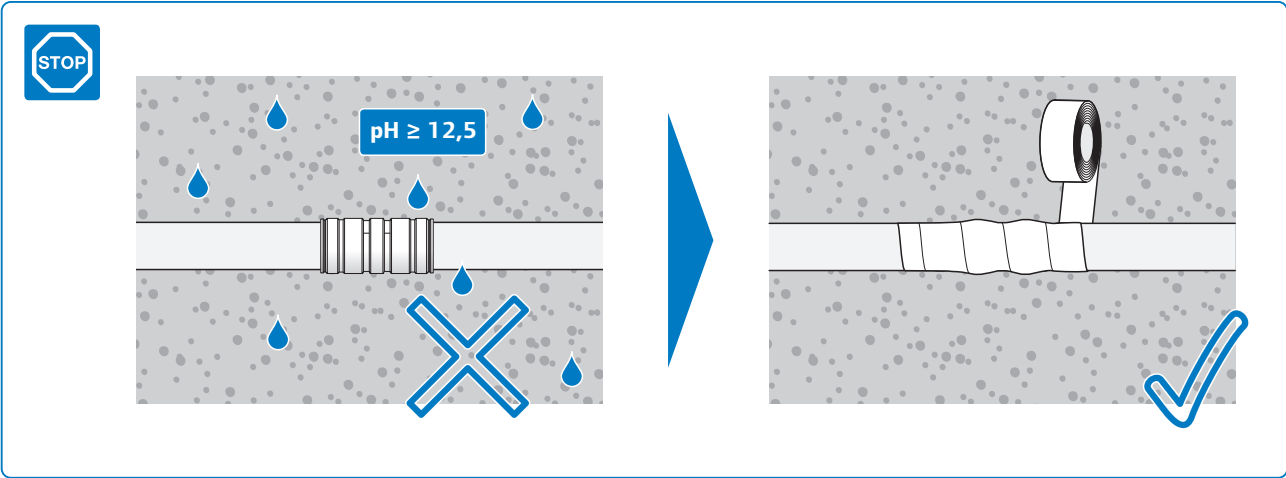
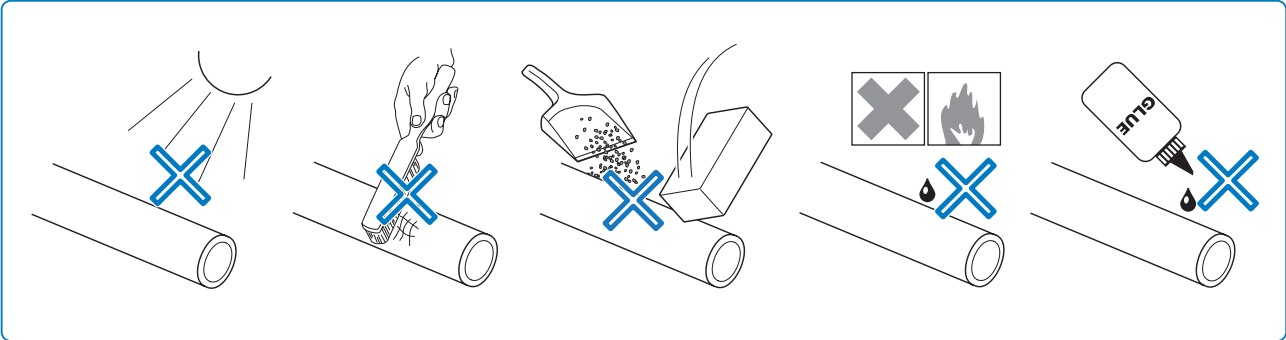

d_a [mm]	R_{min} [mm]
16	80
20	100

16 - 20 mm

d_a [mm]	R_{min} [mm]
16	64
20	80

d_a [mm]	R_{min} [mm]
16	46
20	80

$$\Delta l \text{ [mm]} = \Delta\theta \text{ [K]} \cdot 0,025 \left[\frac{\text{mm}}{\text{m} \cdot \text{K}} \right] \cdot L \text{ [m]}$$

$$BS \text{ [mm]} = 30 \cdot \sqrt{d_a \text{ [mm]} \cdot \Delta l \text{ [mm]}}$$

Dim. [mm]	L, max
16 × 2,0	2,00
20 × 2,25	2,30

Dim. [mm]	H, max
16 × 2,0	2,30
20 × 2,25	2,60

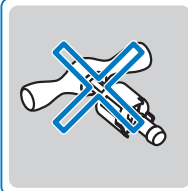

16 - 20 mm

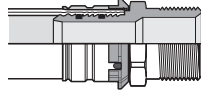



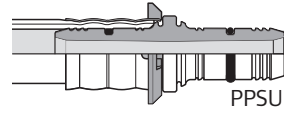



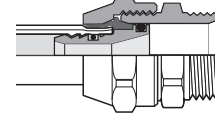

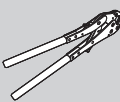
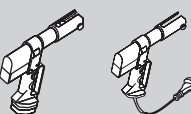
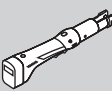
16 - 20 mm



16 - 20mm



				
				
PPSU	16 - 20	16 - 20	16 - 20	-
	16 - 20	16 - 20	16 - 20	-
	-		-	-
		16 - 20		
	-	-	-	16 - 20

16 - 20 mm

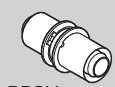

PPSU

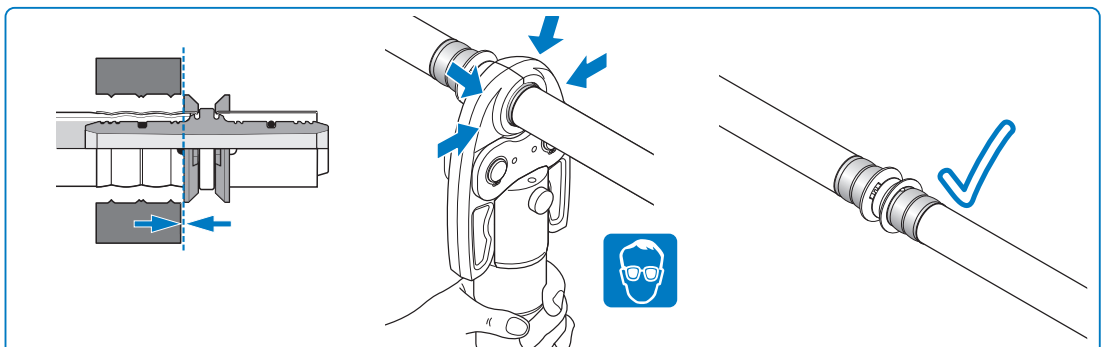
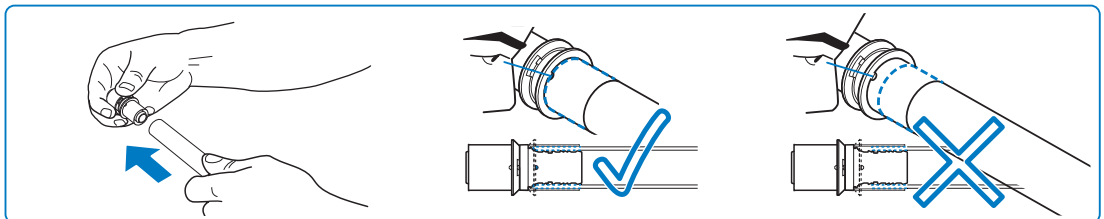

16 – 20 mm

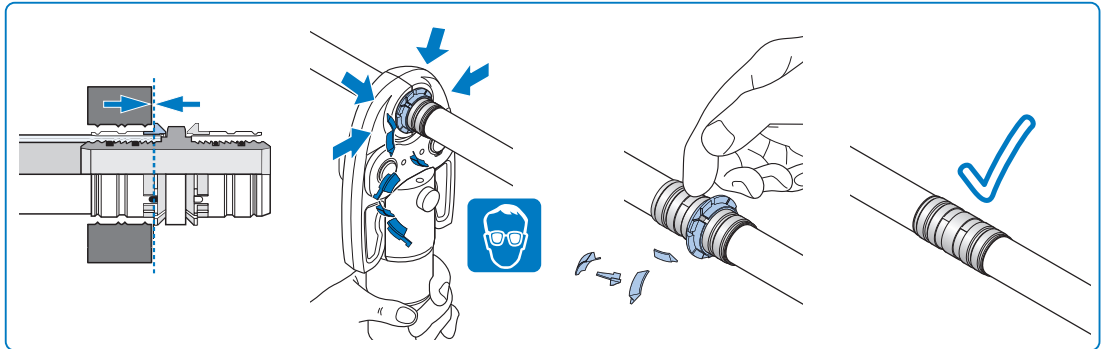
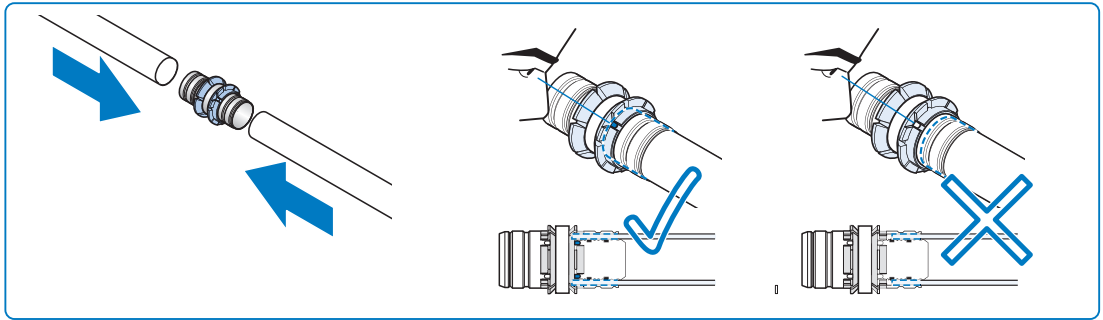

16 – 20 mm

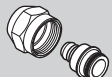

Metal

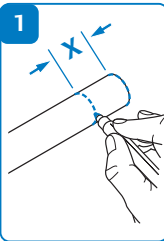

Fitting Dim.	X [mm]
16 – 1/2"	8
20 – 1/2"	10

Fitting Dim.	X [mm]
16 – 3/4"	10
20 – 3/4"	10

Fitting Dim.	X [mm]
16 – 1/2"	9
Geberit	

