

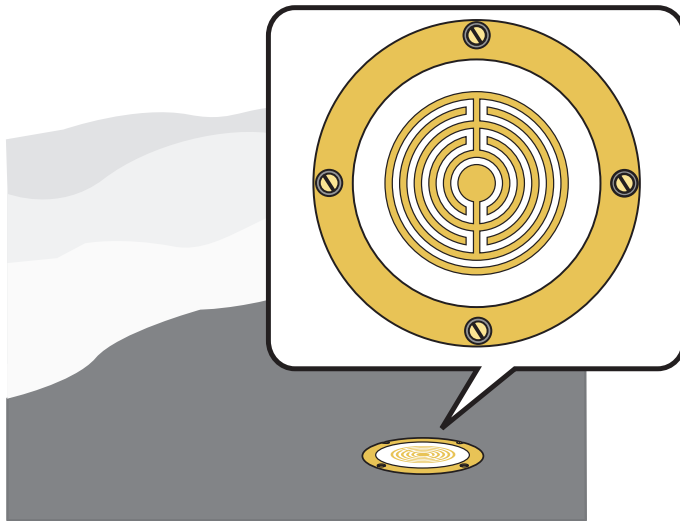

RADIANT HEATING SYSTEMS
PAVEMENT
SNOW AND ICE SENSOR

INSTALLATION AND
OPERATION MANUAL



Pavement Snow and Ice Sensor (A3040090)

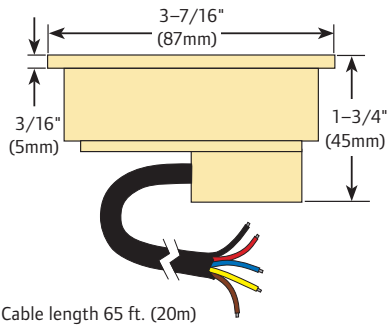

Pavement Snow and Ice Sensor Installation and Operation Manual

The Uponor Pavement Snow and Ice Sensor (A3040090) and Pavement Snow and Ice Sensor Cup (A3040091) are used with the Uponor Single-zone Snow Melt Control (A3040654).

The sensor is designed to sit flush with the slab surface after being mounted into the cup. The cup is

installed directly into the snow melt slab halfway between the heating elements or pipes.

The sensor, which comes with a 65-ft. (20m) cable, measures the slab temperature, sensor surface temperature and sensor surface moisture level.

Pavement Snow and Ice Sensor Cup (A3040091)

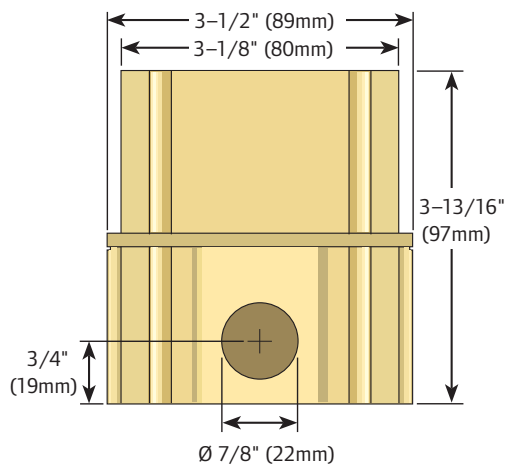

Pavement Snow and Ice Sensor (A3040090)

- Automatic snow and ice detection
- Slab temperature sensing
- 65-ft. cable eliminates in-field splicing
- Durable for driveway and walkway installations
- For use with Uponor Single-zone Snow Melt Control (A3040654)

Pavement Snow and Ice Sensor Cup (A3040091)

- Provides mounting solution for Pavement Snow and Ice Sensor (A3040090)
- Includes mounting plate

Important Safety Information



Warning

It is your responsibility to ensure that this control is safely installed according to all applicable codes and standards. Uponor is not responsible for damages resulting from improper installation and/or maintenance.

To avoid serious personal injury and damage to the equipment:



- Read manual and all product labels before using the equipment. Do not use unless you know the safe and proper operation of this equipment.
- Keep this manual available for easy access by all users.
- Replacement manuals are available at www.uponorpro.com.



- Disconnect all power before opening the control.

- It is the installer's responsibility to safely install this control according to all applicable codes and standards.
- Improper installation and operation of this control could result in damage to the equipment and possibly even personal injury or death.
- This electronic control is not intended for use as a primary limit control. Only place controls that are intended and certified as safety limits into the control circuit.
- Do not attempt to service the control. There are no user serviceable parts inside the control. Attempting to do so voids the warranty.

Radio Frequency Interference

The installer must ensure this control and its wiring are isolated and/or shielded from strong sources of electromagnetic noise. Conversely, this Class B digital apparatus complies with Part 15 of the FCC Rules and meets all requirements of

the Canadian Interference-Causing Equipment Regulations. However, if this control causes harmful interference to radio or television reception, (determined by turning the control off and on) try to correct the interference by re-orientating

or relocating the receiving antenna, relocating the receiver with respect to this control, and/or connecting the control to a different circuit connected to the receiver.

Uponor Pavement Snow and Ice Sensor Installation and Operation Manual

is published by

Uponor, Inc.
5925 148th Street West
Apple Valley, MN 55124 USA
Tel: 800.321.4739
Fax: 952.891.2008
www.uponorpro.com

Uponor Ltd.
2000 Argentia Rd., Plaza 1, Ste. 200
Mississauga, ON L5N 1W1 CANADA
Tel: 888.994.7726
Fax: 800.638.9517
www.uponorpro.com

© 2014 Uponor. All rights reserved.

First Edition
First Printing September 2014
Printed in Canada

Uponor has used reasonable efforts in collecting, preparing and providing quality information and material in this manual. However, system enhancements may result in modification of features or specifications without notice.

Uponor is not liable for installation practices that deviate from this manual or are not acceptable practices within the mechanical trades.

Package Contents

Check the contents of this package. If any of the contents listed are missing or damaged, please contact your wholesaler or Uponor sales representative for assistance.

Sensor package includes:

- One Pavement Snow and Ice Sensor (A3040090) with O-ring
- Four, #6-32 x $\frac{3}{8}$ " screws
- Four, #4-40 x $\frac{7}{16}$ " screws
- One manual

Sensor cup package includes:

- One Pavement Snow and Ice Sensor Cup (A3040091)
- One protective plastic plug
- One plastic mounting plate
- Eight, #6-32 x $\frac{3}{8}$ " screws
- One manual

Sensor Installation

Sensor Location

The location of the sensor determines how well the snow melt detector responds to conditions on the snow melting slab. The sensor measures the temperature of the slab surface. It should normally be installed in a location that is representative of the average surface temperature and moisture conditions. The only exception to this practice would be those applications where the sensor is placed in a specific problem area where ice or snow often forms first.

The installer should be careful to place the sensor in a location where it will not be affected by abnormal temperature conditions that may occur near buildings, hot-air exhaust ducts or other heat sources, or sunny areas within a larger slab area.

As well as reading temperatures, the sensor also detects surface water. The installer should be careful not to place the sensor where standing water could accumulate on its surface. Standing water in the cup may cause the snow melt system to activate far longer than necessary, as

the control will be receiving a signal that water is present even though the rest of the slab surface may be dry. Conversely, do not place the sensor in areas where drainage is considerably better than the surrounding area.

Do not install the sensor in locations where vehicles park, near building overhangs or near trees since this may interfere with snow fall accumulation. If in doubt about the location of these obstacles, a second spare cup and conduit can be installed to provide a backup sensor location.

Vehicle tire and pedestrian traffic can track water and contaminants onto the snow melt area. If the sensor is located in the traffic area, snow melting will be triggered by the passing traffic. This may be desirable in commercial areas where excessive traffic can cause the surface to become icy. In residential installations, the amount of traffic is usually limited, and it may be desirable to locate the sensor away from the traffic area. This will reduce the number of snow melt events

that occur and thereby reduce the annual energy consumption. Be sure to locate the sensor midway between the heating pipes or elements.

Conduit

Place the sensor cup at the chosen location and run a conduit for the cable from the cup to the snow melting control. If more than the included length of cable is required to reach the control, run the conduit to a weatherproof junction box. The sensor cable should be run in its own conduit and not in combination with high-voltage wiring. The conduit length from the sensor to the junction box should be less than the length of cable supplied with the sensor. At the junction box, additional 18 AWG, 5-conductor cable can be spliced on to increase the total length to 500 ft. (150m) from the sensor to the control.

Avoid tying the conduit to the rebar within 6 ft. (2m) of the cup. This allows the rebar grid to move without disturbing the position of the cup.

Sloped Surfaces

The top of the sensor should be flush and parallel to the snow melt surface. When installing the sensor on a sloped driveway, ensure the sensor is installed near the lowest elevation of the slope. This is necessary since the melting snow or ice runoff water will drain toward the lowest point on the driveway and keep this area wet for longer periods of time.

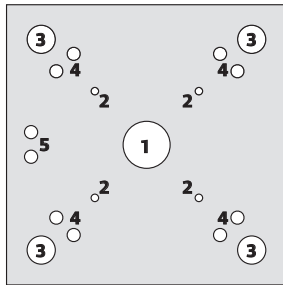
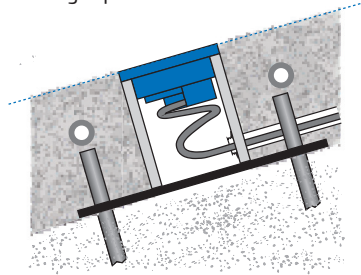
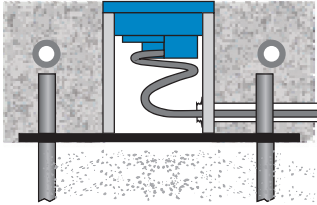

Mounting Plate

1. Drainage hole
2. Socket screw holes
3. Rebar holes
4. Rebar tie holes
5. Conduit tie holes

Installing the Cup

A mounting plate is included to simplify the installation of the sensor cup. When possible, locate the mounting plate directly on top of gravel to provide good drainage. If the slab is more than 4" thick, use a mound of crushed rock or a styrofoam or wooden block to elevate the cup. Punch or drill a hole in the styrofoam or wooden block to provide drainage.

Note: Failure to provide adequate drainage under the cup may reduce the life expectancy of the sensor.

Fasten the mounting plate to the ground using 1/2" (12.7mm) rebar through the four holes located on each of the four corners. Then, tie the mounting plate to the rebar.

1. Cut four pieces of rebar at least 12" (300 mm) long.
2. Drive the rebar into the ground through each of the mounting plate rebar holes. Leave approximately 2" (50 mm) of rebar above the ground.
3. Cut several 12" (300 mm) pieces of steel wire.
4. Form a "U" shape and pull wire through the rebar tie hole from the bottom to the top side.
5. Repeat by pulling the "U" shape from the top to the bottom side.
6. Repeat Steps 4 and 5 for each of the four corners.
7. Cross the wire, then wrap around the rebar.
8. Twist wire using pliers to tighten.

The mounting plate also has conduit tie holes to allow a cable tie or steel wire to fasten the conduit to the mounting plate.

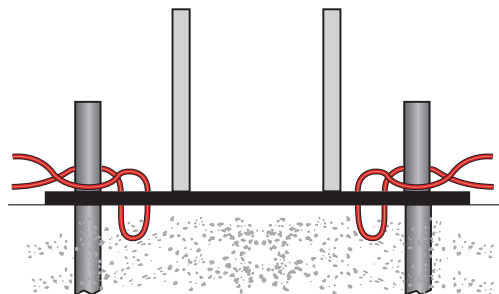
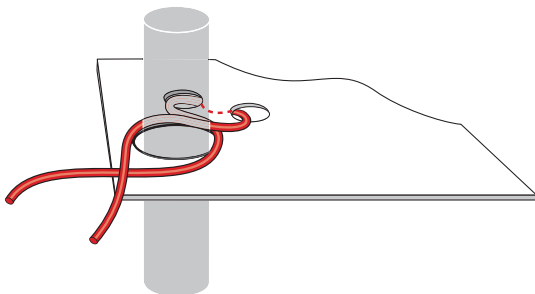

Placing Concrete

A plastic plug is provided with the cup to prevent it from being accidentally filled with concrete. The plastic plug is the same thickness as the sensor flange. This allows the finished surface of the concrete (asphalt, etc.) to be troweled flush with the plug. The plug must be installed prior to placing the concrete. Also, ensure the mounting plate drainage hole remains unplugged once the concrete has cured.

Installing Brick Pavers

If using brick pavers instead of concrete, it is recommended to mortar surrounding brick pavers to the side of the cup. This ensures good thermal conduction from the brick pavers to the cup. The top of the brick pavers should be level with the cup when the plastic plug is installed.

Install the Sensor and Cable

When the snow melt surface is finished, remove the plastic plug from the cup and fish the cable through the conduit until there is only 6" to 12" (150 to 300mm) of cable between the sensor and conduit. Loop this remaining extra wire in a loose coil so as to not twist it, and place it and the sensor into the cup. Secure the sensor to the cup with the four screws provided, making sure the O-ring is in place and properly seated.

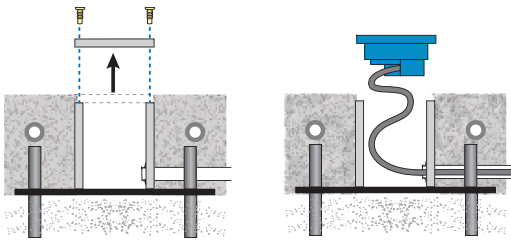

Placement in Existing Sensor Cup

Current versions of the sensor cup use #6-32 screws. Previous versions of the cup used smaller #4-40 screws. When replacing the sensor, both sets of screws are provided. It is recommended to try the smaller screws first to avoid cross threading.

Salt and Brine Contamination

The performance of the sensor's water detection can be compromised when exposed to de-icing agents such as road salt, magnesium chloride or calcium chloride. These contaminants can permanently damage the sensor. It is recommended to locate the sensor away from areas exposed to these deicing agents when at all possible. Locations to avoid could include tire track areas or areas close to a curb where traveling vehicles may splash contaminated water onto the sensor.

Maintenance

The sensor is installed in a harsh environment. Accumulation of dirt, salty grime, etc., on its surface will inhibit proper water detection. Check the sensor on a regular basis and, when necessary, clean it. Before cleaning, shut off the control power to prevent the control from entering the snow melt mode. Next, use a soft bristle brush and warm soapy water to clean the sensor surface. Do not use a steel wire brush as this will damage the sensor. Use a paper towel to thoroughly dry the sensor surface. After cleaning, re-power the control.

Electrical Connections

The sensor cable has five wires: red, black, blue, yellow and brown. The wires connect to the respective red, black, blue, yellow and brown terminals on the Uponor Single-zone Snow Melt Control (A3040654).

Uponor Single-zone Snow Melt Control (A3040654)

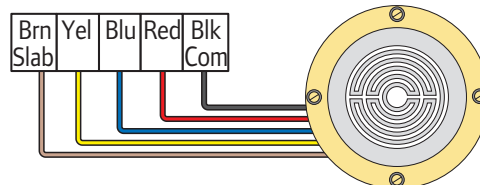

Pavement Snow and Ice Sensor (A3040090)

Sensor Testing

When performing these tests:

- The sensor head should be installed in the slab.
- The five cable wires at the control should be disconnected.
- Use a good quality electrical testing meter with an ohm scale range of 0 to 2,000,000 Ohms.

The sensor has two 10k Ohm thermistors. One reads slab surface temperature and the other checks sensor heater temperature. If the sensor has been disconnected from the control for an hour or more, the

readings for both thermistors should be very close. Using the ohmmeter and standard testing practices, measure the resistance between:

- (a) The yellow and black sensor wires (sensor temperature), and
- (b) The brown and black sensor wires (slab temperature).

The table below lists the expected resistance values at various sensor temperatures. Measure the resistance between the blue and black wires. When the sensor surface is dry, the reading should be 2,000,000

Ohms. When the sensor surface is wet, it should be between 10,000 and 300,000 Ohms. Measure the resistance between the red and black wires of the heating element. This reading should be close to 50 Ohms.

Temperature vs. Resistance Table

Temperature		Resistance
°F	°C	Ω
-50	-46	490,813
-45	-43	405,710
-40	-40	336,606
-35	-37	280,279
-30	-34	234,196
-25	-32	196,358
-20	-29	165,180
-15	-26	139,402
-10	-23	118,018
-5	-21	100,221
0	-18	85,362
5	-15	72,918
10	-12	62,465
15	-9	53,658
20	-7	46,218
25	-4	39,913

Temperature		Resistance
°F	°C	Ω
30	-1	34,558
35	2	29,996
40	4	26,099
45	7	22,763
50	10	19,900
55	13	17,436
60	16	15,311
65	18	13,474
70	21	11,883
75	24	10,501
80	27	9,299
85	29	8,250
90	32	7,334
95	35	6,532
100	38	5,828
105	41	5,210

Technical Data

Pavement Snow and Ice Sensor (A3040090)

Packaged weight	4.4 lb (2000 g)
Dimensions	1 ³ / ₄ " H x 3 ⁷ / ₁₆ " OD (45mm H x 87mm OD)
Sensor material	Silicon brass
Cable Material	65 ft. (20m) 5-conductor stranded wire with polyethylene jacket
Approvals	CSA C US with Uponor Single-zone Snow Melt Control (A3040654)
Operating range	-30 to 170°F (-34 to 77°C)
Included	4 #4-40, ⁷ / ₁₆ " machined, stainless steel screws 4 #6-32, ³ / ₈ " flathead, slotted, stainless steel screws

Pavement Snow and Ice Sensor Cup (A3040091)

Packaged weight	1.5 lbs (670 g)
Socket material	Silicon brass
Dimensions	3 ¹³ / ₁₆ " H x 3 ¹ / ₂ " OD (97mm H x 89mm OD)
Approvals	CSA C US with Uponor Pavement Snow and Ice Sensor (A3040090)
Included	One polyethylene protective cap, one polyethylene mounting plate and eight #6-32 x ³ / ₈ " screws

Notice

The Pavement Snow and Ice Sensor (A3040090) must be operated by an Uponor Single-zone Snow Melt Control (A3040654). Operation of the sensor by third-party control systems may result in electrolysis failures not covered by the warranty.

Uponor, Inc.
5925 148th Street West
Apple Valley, MN 55124 USA
Tel: 800.321.4739
Fax: 952.891.2008

Uponor Ltd.
2000 Argentia Rd., Plaza 1, Ste. 200
Mississauga, ON L5N 1W1 CANADA
Tel: 888.994.7726
Fax: 800.638.9517



www.uponorpro.com