

uponor



Smatrix

The intelligent control system
for radiant heating and cooling

More comfort for less energy



Uponor Smatrix: the smartest way to optimise comfort, energy management and cost

Smatrix is a fully integrated control system for radiant heating and cooling – from water supply all the way to air temperature monitoring on the wall.

Self-learning and **intelligent**, Smatrix features **autobalancing** technology that constantly anticipates and adjusts the exact amount of energy needed to ensure optimal comfort at all times.

Smatrix is designed specifically for radiant heating and cooling.

- **Easy to install:**
Less wiring – or completely wireless
- **Easy to use:**
Intelligent algorithms optimise the system automatically and constantly for both wired and wireless controls
- **Easy to control:**
Optimum energy output for individual comfort

Smatrix creates value

Smatrix is easy to install, set up and maintain. The intelligent modular system offers invaluable benefits for everyone.

Smatrix is the most comfortable way to save energy and costs **in your home** – and at the same time improve individual comfort.

Smatrix is ideal for **specification** because it offers a fully integrated and easily expandable system with outstanding service before and after installation.

Less wiring and easy setup on **installation** save time and money. And there is no need for time-consuming commissioning anymore.

Distributors can be sure that the complete, integrated Smatrix portfolio is a perfect fit for installers' and householders' needs.



Smatrix Wave PLUS, featuring easily programmable thermostats and central control with touchscreen interface

Autobalancing: continuously self-optimising temperature control

A unique technology that eliminates the need for manual balancing



Learning

open
closed



Balancing short loops

open
closed



Balancing long loops

open
closed

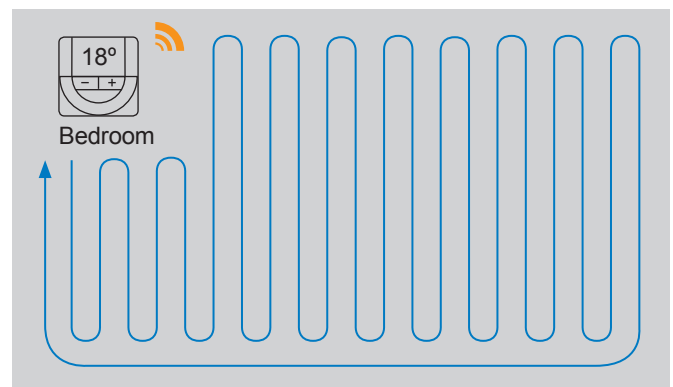
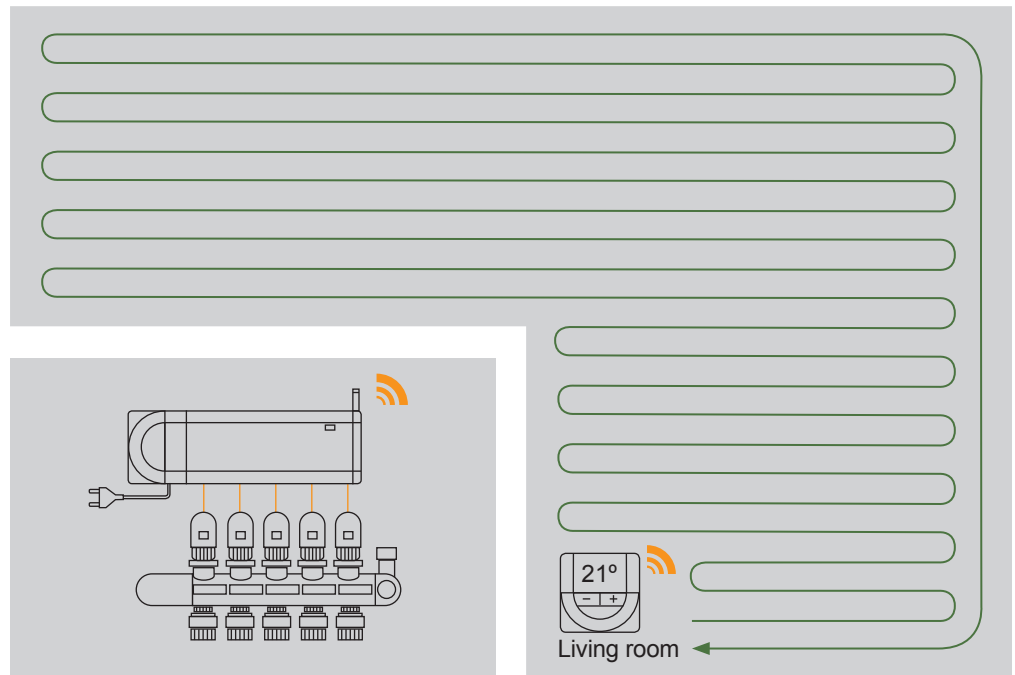

Example settings
Autobalancing heat circuits means short and long loops are opened and closed at just the right time with the exact amount of energy needed.

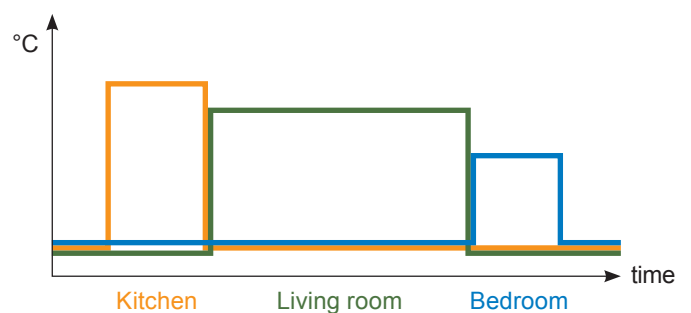



Autobalancing constantly monitors changes in conditions inside and outside the building. By intelligently adjusting and adapting, Uponor Smatrix ensures that just the right amount of energy is used at just the right time.

With traditional controls, radiant heating and cooling needs balancing to fixed design conditions. This is a manual process that needs later adjustment to suit the actual building and occupiers preferences - a time consuming trial and error procedure. Autobalancing not only eliminates this initial commissioning adjustment - periodically the system optimises the circuit of each room, continuously calculating the energy required for your comfort. Even if you change floor coverings, autobalancing will adapt automatically to ensure the right comfort levels with the most efficient energy use.

For renovation

Using Smatrix, autobalancing can also be retrofitted in existing radiant heating and cooling systems in renovation, optimising comfort and energy consumption. Even with no prior knowledge of the existing system, Smatrix allows you to improve the performance of your overall system easily and instantly. To sum up, autobalancing means perfect intelligent heat distribution – permanently.

- Retrofit optimises existing installations
- Improved comfort without manual adjustments
- Fully automatic, 24/7
- Up to 25% faster reaction
- Energy saving:
 - Up to 6% compared to other single-room controls
 - Up to 12% compared to unbalanced systems
 - Up to 20% compared to unbalanced multi-zone systems

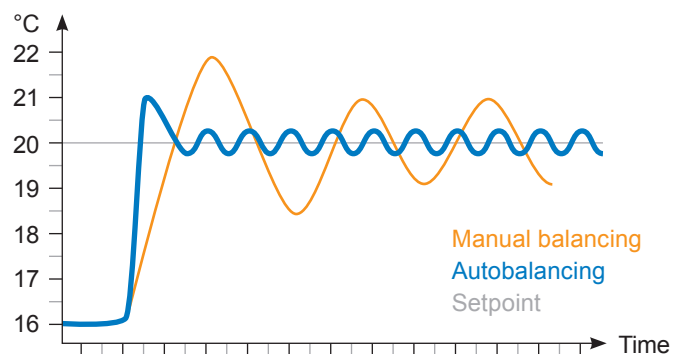

While manual balancing reflects a certain point in time of your system, autobalancing adapts to every change in your system or building – without the additional calculations manual balancing requires. This saves energy and leads to an exact room temperature for your optimal comfort.

Less wires, more efficiency

Uponor Smatrix is ideal for renovation and reduces installation time in new buildings too

Smatrix easily adapts to existing installations. It even balances older systems automatically – improving room comfort and maximising efficiency. Due to robust radio communication, the installation process is perfect for renovation. Of course Smatrix also reduces the installation time in new buildings.

Extra flexibility is provided by the modular system architecture, which allows you to add functionalities or outputs when needed – and not before.

- **Wireless transmission with Uponor Smatrix Wave and Wave PLUS**
- **Works with existing installations**
- **Fast and easy installation**





Smart controls, intelligent features

Room check detects whether the thermostats are properly assigned to the loops.

- Avoids trouble after installation
- Informs in case of a thermostat mix-up
- Helps in renovation when system knowledge is limited

Room bypass secures the necessary water flow for the heat pump with a single-room control if a buffer tank is too small for the system.

- Increases the life span of the heat pump
- Ensures performance

Comfort setting maintains the comfort by providing a warmed floor even if alternative heat sources are in use.

- Avoids a cooling down of the floor
- Reacts fast
- Saves energy during reactivation

Cooling function increases your options and comfort.

- Fewer devices to install, lower costs
- Higher protection to avoid condensation

Data storage: with a micro SD card for Uponor Smatrix Wave PLUS, you can keep the system up to date.

- Data cloning
- Software updates
- Long-term data logging
- System backup

Trend visualisation displays and compares temperature settings room by room – the fastest way to improve energy consumption.

- Visualisation of values
- Direct user feedback

System diagnostic

Detects difficulties with ease

Like life itself, comfort and convenience are dynamic. The Uponor Smatrix diagnostic functions detect difficulties in reaching the comfort temperature. And that makes troubleshooting quick and easy. Even better: it improves energy consumption.



- Touchscreen interface with Smatrix Wave PLUS
- Continuous system monitoring
- Improved energy management

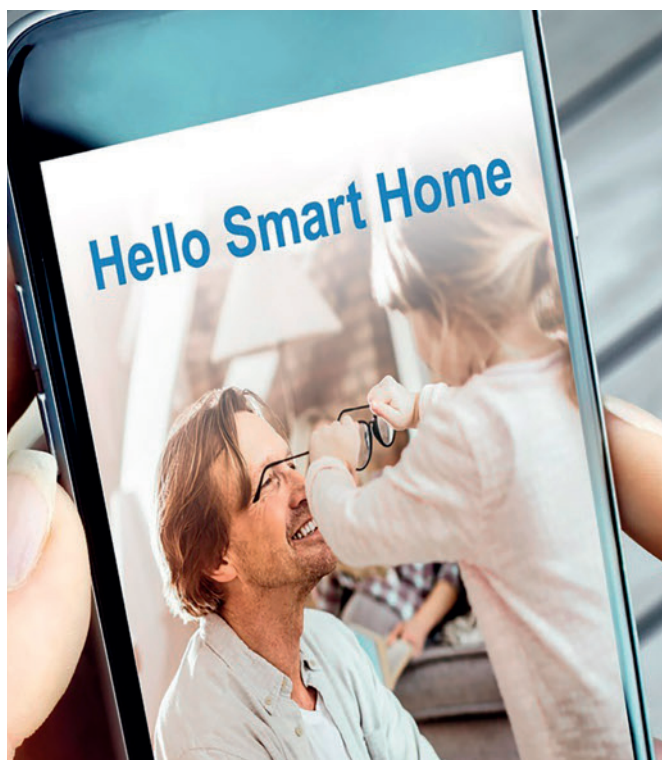

Smatrix App

Controlled comfort at home or away

The Smatrix App allows you to manage the indoor climate from anywhere – via app or web. If you're away for longer than expected, you can save energy and money by remotely adjusting the system to extend ECO settings.

- Plug & play installation
- Real time control and alarm notification
- Energy optimisation with user-friendly visualisation



Uponor Smatrix product range

Multi-zone controls

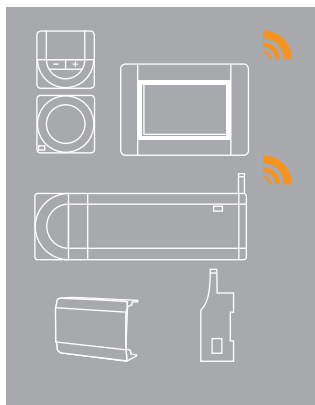

Smatrix Wave

Wireless controller with touchscreen interface and full functionality

- Autobalancing
- Smatrix App
- System diagnostic
- Room bypass
- Cooling function
- Data storage

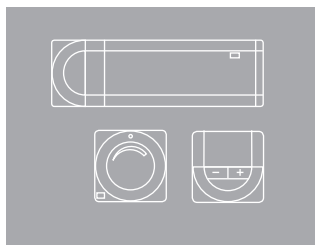

Smatrix Base

Wired room control

- Autobalancing
- Cooling function

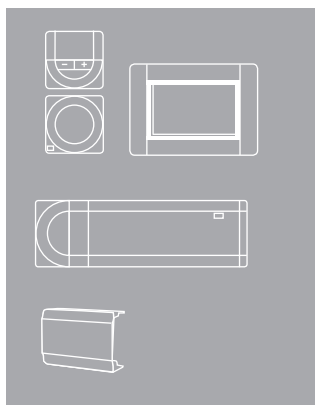

Smatrix Base PRO

Wireless controller with touchscreen interface and full functionality.

- BMS control possible
- Central point of control for up to 192 thermostats
- Autobalancing
- System diagnostic
- Room bypass
- Cooling function
- Data storage

Remote-access controls



Smatrix app

Smartphone app interface

- Smartphone App
- Web access
- Remote monitoring and control

Supply-water controls

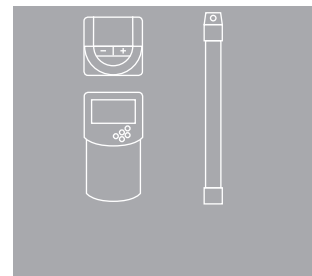

Smatrix Move PLUS

Supply-water control for heating and cooling

- Indoor and outdoor compensation
- Wireless sensors



Uponor: sustainable solutions for a better future

Having started in 1918 in Finland, Uponor today is not only an international plastic pipe specialist, but also one of the leading product and solution suppliers for buildings and infrastructures across Europe, North America and selected markets. Around 4,000 employees at 30 international locations are striving to deliver new technologies and solutions to sustainably enrich people's way of life.

We focus on safe potable water supply as well as comfortable indoor climate. For the various target groups including installers, distributors and investors, Uponor offers a uniquely broad portfolio and turnkey solutions for public, commercial and residential buildings alike.

Who we are

- A leading international supplier of building and infrastructure solutions
- Technologies and solutions for safe potable water supply and comfortable indoor climate
- Approx. 3,700 employees in 30 countries
- Sales and service in more than 100 countries
- Listed on NASDAQ OMX Helsinki in Finland

uponor



www.uponor.co.uk

Uponor UK

The Pavilion, Blackmoor Lane
Watford
Hertfordshire
WD18 8GA

+44 (0)1923 927000
enquiries.uk@uponor.com
www.uponor.co.uk