



# FLOOR HEATING CONTROLS WIRING INSTRUCTIONS FOR BA CONTROLS



## FIRST FIX FOR velta WLM CONTROLS

### CONTROL BOXES

#### BA MASTER

- 230V switch fuse spur to each manifold
- 2 core wire to boiler location – to signal boiler (if required)
- 3 core wire to secondary pump (if required)
- 2 core wire from volt free contact for external timer/signal (if required) (Terminals 17/18)
  
- Additional add on units require 230V power supply and linking to the main master controller (requires 4 core data wire).

### NETWORK

4 core cable between all manifolds, maximum size of cable is 1.0mm solid core or 0.75mm multi strand. Terminations are RJ11/RJ14 connections. Extension box link cable between boxes supplied by others, as shown on network diagram (Connection boxes can be purchased from velta)

Refer to WLM2 installation instructions for set up (See page 5 of WLM2 instructions).

Maximum cable length - 600 metres. Please do not connect these network links to the box terminals until a velta engineer is present to commission.

### SENSORS

Can be wired either in series (daisy chain) or star wired. Refer to figures 3A & 3B of these instructions.

The maximum size of cable for the sensors is 1.0mm solid core or 0.75mm multi strand.

**Do NOT use larger dimension cable, as this will stress the terminals and p.c.b's of the thermostats.**

The thermostat connections are all 2 core, so remember to identify and maintain the + and – continually throughout. Each sensor has loop terminals for incoming and outgoing cables.

Note that if the sensors are run in series (daisy chain), a return cable from the last sensor to the master control box is required.

### BEAD SENSORS

These must be connected back to a thermostat (WLTm) only, using terminals 5 & 6 (25m max. cable run). The jumper connection must be made in the thermostat.

### LIMIT SENSORS

Jumper connection made = maximum limit – jumper connection removed = minimum limit

### WIRELESS RECEIVER

If using wireless control thermostats, please note a receiver is required to each master controller. This is a simple plug and play connection. (Lead supplied).

If there is difficulty in reaching each wireless room sensor, more than one receiver can be used i.e. 1no. to a master & 1no. to an add-on module.



NOTE: Do not place the receiver near to power cables and metal/stud work. In case of communication problems, it may be necessary to move the location of the receiver, or to add an additional receiver.

Communication frequency .....868 MHz

## **HEATING & COOLING**

**NOTE: We do not provide automatic change over**

BA cooling kit is required when a BA master is the network master. BA cooling kit contains the following items:

1 x WLAC Heating & Cooling Switch – manual or signal operated This sensor can be wired in series with the thermostats or alternatively, can be wired directly back to the sensor control bus in the master, depending on preferred method

Signal operated from any control provided by others. This is a volt free, make or break connection and will require a 2 core cable maximum size of cable is 1.0mm solid core or 0.75mm multi strand from source. This is connected directly to the WLAC. Please note that that the manual select switch must be heating mode when other supplies signal.

Manual operation this is by use of the select switch on the WLAC. We will require a 2 core power cable from the X Output in the master to heating/cooling source. Please note a K module maybe require if you are operating a separated boiler/chiller.

1 x WLH – Humidity Sensor, This sensor can be wired in series with the thermostats or alternatively, can be wired directly back to the sensor control bus in the master, depending on preferred method

1 x ETF1899A – Flow Sensor connected to the return pipe on manifold. This sensor is wired to the supply sensor, terminals 49/50.

**FOR SECOND FIX INFORMATION, PLEASE REFER TO INSTALLATION & OPERATION MANUALS**

# WIRING DIAGRAM FOR WLM2 - BA MASTER

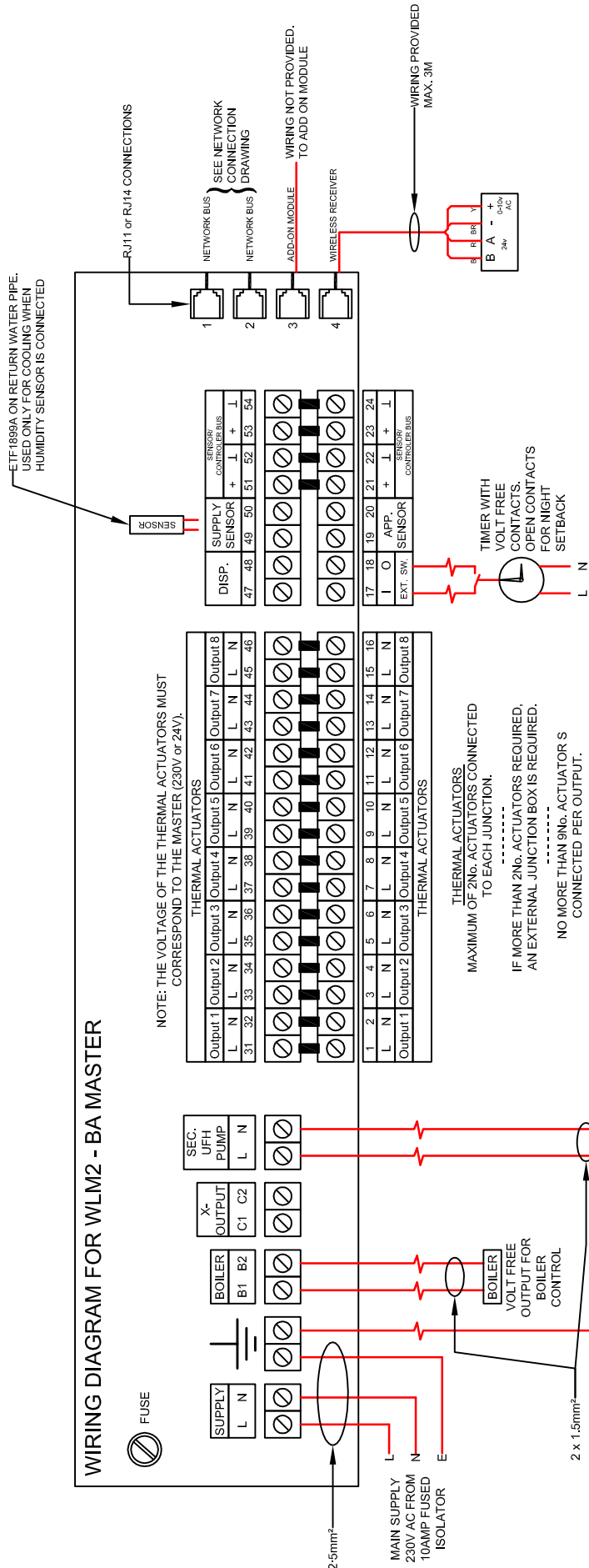

NOTE: THE VOLTAGE OF THE THERMAL ACTUATORS MUST CORRESPOND TO THE MASTER (230V or 24V).

THERMAL ACTUATORS  
 MAXIMUM OF 2No. ACTUATORS CONNECTED TO EACH JUNCTION.  
 IF MORE THAN 2No. ACTUATORS REQUIRED, AN EXTERNAL JUNCTION BOX IS REQUIRED.  
 NO MORE THAN 9No. ACTUATOR S CONNECTED PER OUTPUT.

ALL WIRE TO SENSOR BUS TO BE Max. 2 x 0.5mm², Max. 100m LONG.

- W/LAC SWITCH MODULE
- W/LOC - OUTDOOR COMPENSATION MODULE, TO BE LOCATED ON NORTH FACING ELEVATION
- W/LH HUMIDITY SENSOR
- SENSORS (W/LTA, TM, TD)
- W/LCT

UP TO 8 DIFFERENT ZONES CAN BE CONTROLLED BY THE MASTER. CONNECT THE THERMAL ACTUATORS ON THE LOOP(S) FOR EACH ZONE TO THE CORRESPONDING TERMINALS ON THE MASTER.

# PLEASE MATCH THE NUMBER ON THE DRAWING INSIDE THE SENSOR SYMBOL TO THE OUTPUT USED ON THE CONTROL LOOP

MULTIPLE MASTERS / ADD ON CONTROL BOXES OPERATING A SINGLE PUMP:  
 CONSIDERATION IS TO BE TAKEN WHEN YOU HAVE A 3 PHASE ELECTRICAL SPLIT.  
 IF IN DOUBT, PLEASE CALL velta TO DISCUSS

ALL ELECTRICAL WIRING TO BE CARRIED OUT BY A QUALIFIED ENGINEER, IN ACCORDANCE WITH MANUFACTURERS DOCUMENTS AND LAST I.E.E. REGULATIONS

PLEASE CONTACT velta FOR ALTERNATIVES

Figure 1.

# WIRING DIAGRAM FOR WLM2 - ADD ON

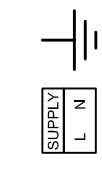

THERMAL ACTUATORS		Output 1	Output 2	Output 3	Output 4	Output 5	Output 6
L	N	L	N	L	N	L	N
31	32	33	34	35	36	37	38
39	40	41	42				

NOTE:  
THE VOLTAGE OF THE THERMAL ACTUATORS MUST CORRESPOND TO THE MASTER (230V or 24V).

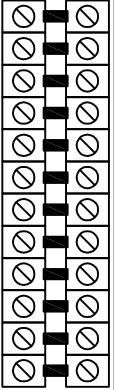

THERMAL ACTUATORS		Output 1	Output 2	Output 3	Output 4	Output 5	Output 6
L	N	L	N	L	N	L	N
21	22	23	24				

THERMAL ACTUATORS  
MAXIMUM OF 2No. ACTUATORS CONNECTED TO EACH JUNCTION.

IF MORE THAN 2No. ACTUATORS REQUIRED, AN EXTERNAL JUNCTION BOX IS REQUIRED.

NO MORE THAN 9No. ACTUATOR S CONNECTED PER OUTPUT.

SENSOR/CONTROLLER BUS		+	-	+	-
51	52	53	54		

2 WIRE LOW VOLTAGE BUS BETWEEN THE SENSOR/CONTROLLERS. CONNECT + to + & - to -. THERMOSTATS CAN BE WIRED AS CONVENTIONAL STAR OR AS BUS CONNECTED MODE (DAISY CHAIN). SEE INSTRUCTIONS FOR FURTHER EXPLANATION.

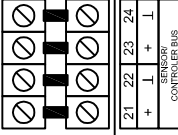

RJ11 or RJ14

MASTER MODULE

WIRING NOT PROVIDED TO MASTER MODULE

WIRELESS RECEIVER

WIRING PROVIDED MAX. 3M

2.5mm<sup>2</sup>

MAIN SUPPLY  
230V AC FROM  
10AMP FUSED  
ISOLATOR PE



UP TO 6 DIFFERENT ZONES CAN BE CONTROLLED BY THE ADD-ON.  
CONNECT THE THERMAL ACTUATORS ON THE LOOP(S) FOR EACH ZONE TO THE CORRESPONDING TERMINALS ON THE ADD-ON.



PLEASE MATCH THE NUMBER ON THE DRAWING INSIDE THE SENSOR SYMBOL, TO THE OUTPUT USED ON THE CONTROL LOOP

ALL WIRE TO SENSOR BUS  
TO BE Max. 2 x 0.5mm<sup>2</sup> Max. 100m LONG.

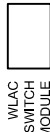

W/LAC - OUTDOOR COMPENSATION MODULE.  
TO BE LOCATED ON A NORTH FACING ELEVATION



W/LH HUMIDITY SENSOR

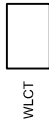

W/LTA SENSORS (W/LTA, TM, TD)



W/LCT

MULTIPLE MASTERS / ADD ON CONTROL BOXES OPERATING A SINGLE PUMP:

CONSIDERATION IS TO BE TAKEN WHEN YOU HAVE A 3 PHASE ELECTRICAL SPLIT.

IF IN DOUBT, PLEASE CALL *velta* TO DISCUSS

ALL ELECTRICAL WIRING TO BE CARRIED OUT BY A QUALIFIED ENGINEER, IN ACCORDANCE WITH MANUFACTURERS DOCUMENTS AND LAST I.E.E. REGULATIONS

PLEASE CONTACT *velta* FOR ALTERNATIVES

Figure 2.

FIRST FLOOR

GROUND FLOOR

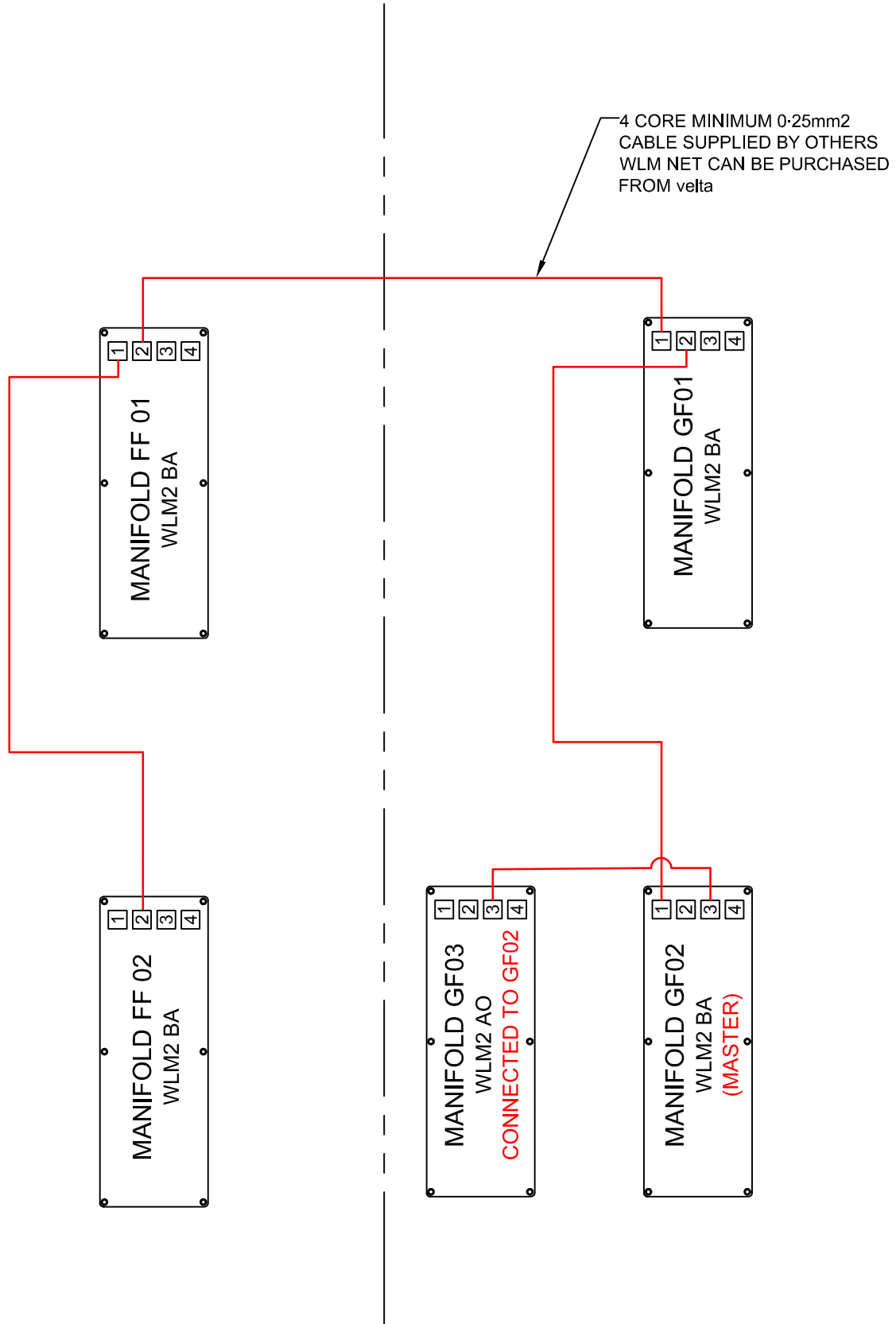

**IMPORTANT NOTE:**

**INTER BOX CONNECTIONS MUST NOT BE MADE UNTIL TIME OF COMMISSIONING.  
FAILURE TO DO SO MAY RESULT IN P.C.B. FAILURE WITHIN THE BOXES**

WLM2 TYPICAL NETWORK CONNECTIONS

Figure 3.

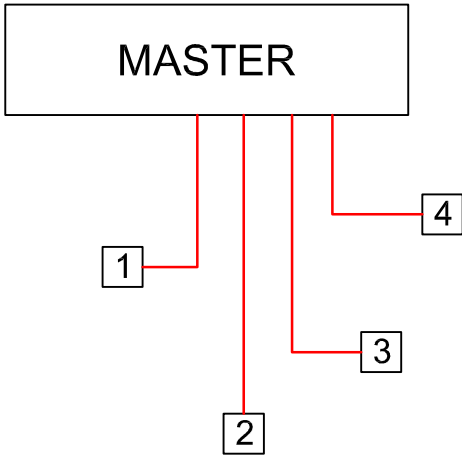

SENSORS  
CONNECTED IN STAR

Figure 3a.

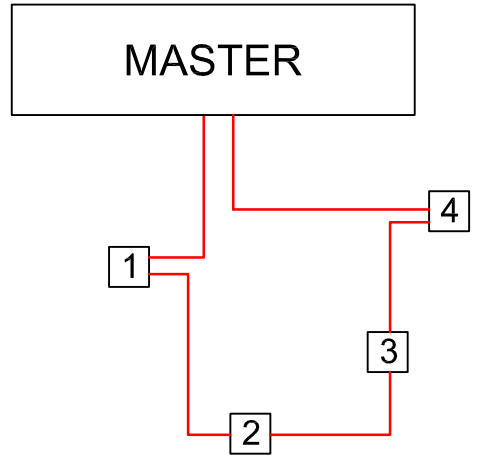

SENSORS  
CONNECTED IN BUS  
MODE  
(DAISY CHAIN)

Figure 3b.

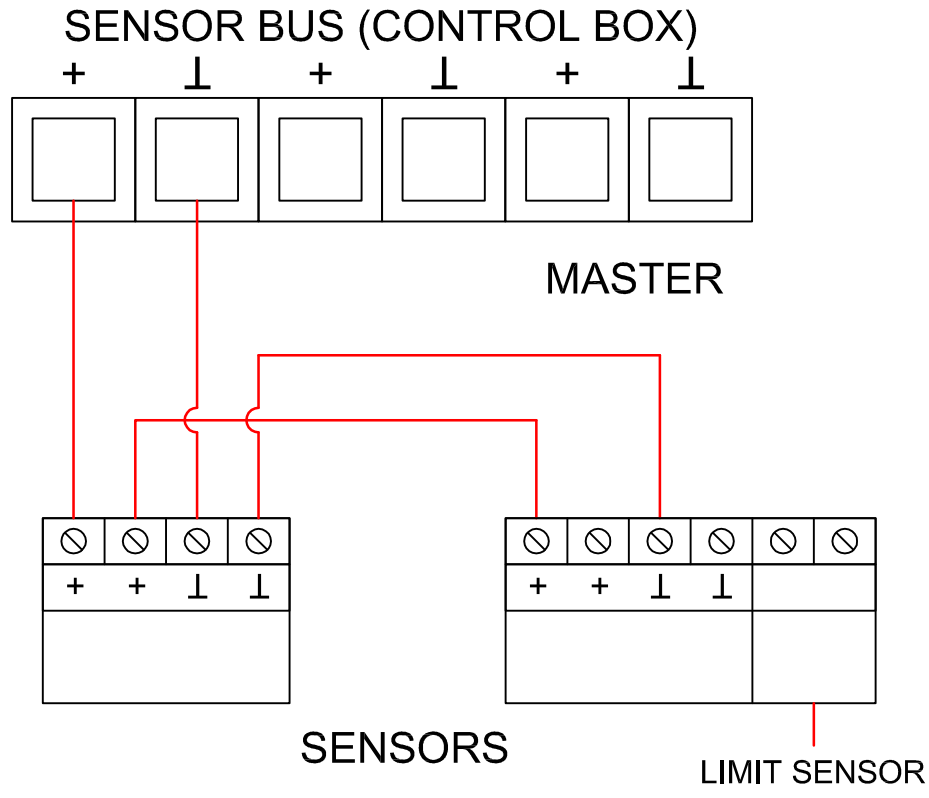

SENSORS - BUS CONNECTION

Figure 4.

# TYPICAL ACTUATOR to CONTROL BOX WIRING SCHEMATIC (SEE Figure 5b)

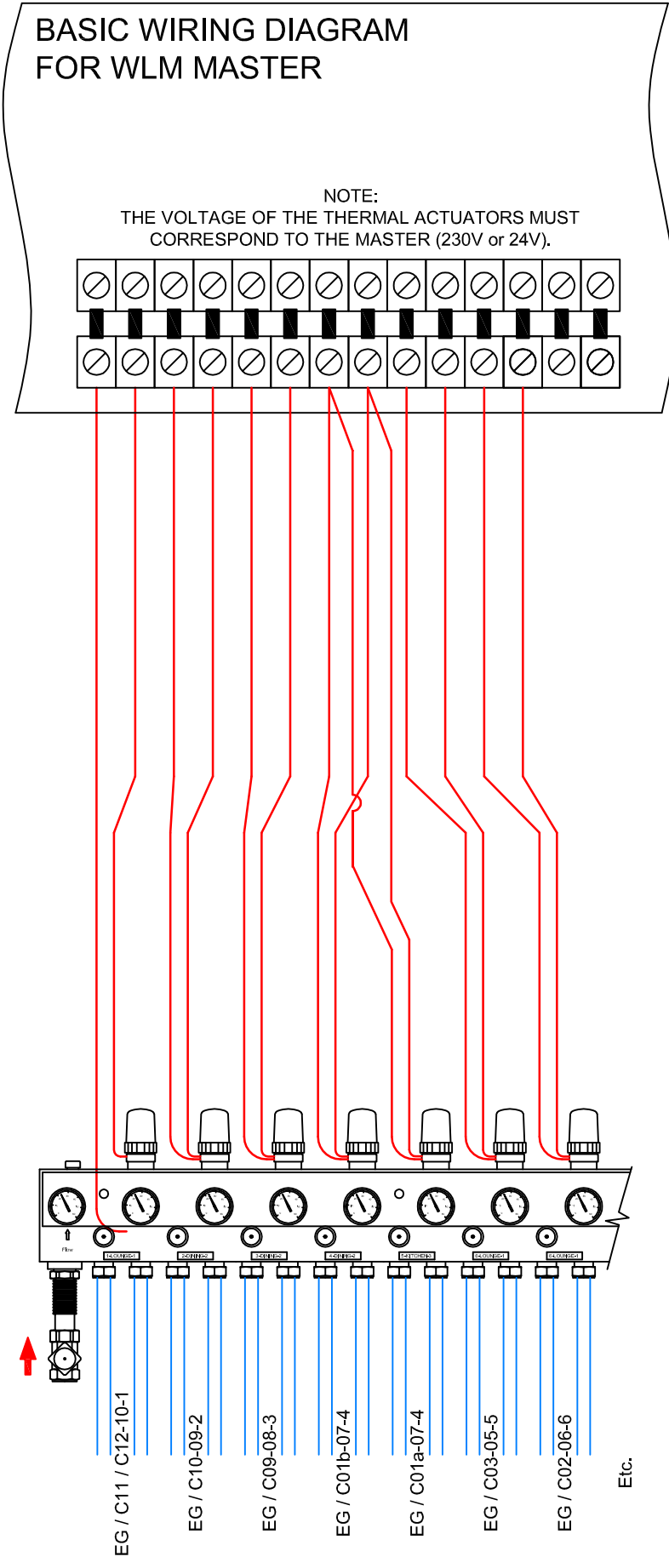

**LABEL KEY** (Example - EG / C09-08-3)  
 EG / C09 = CIRCUIT No.  
 08 = ROOM SERVED  
 3 = CONNECTION NUMBER IN CONTROL BOX (No. AS SHOWN ON THERMOSTAT SYMBOL ON Figure 6b).

-----  
 Figure 5a.  
 -----



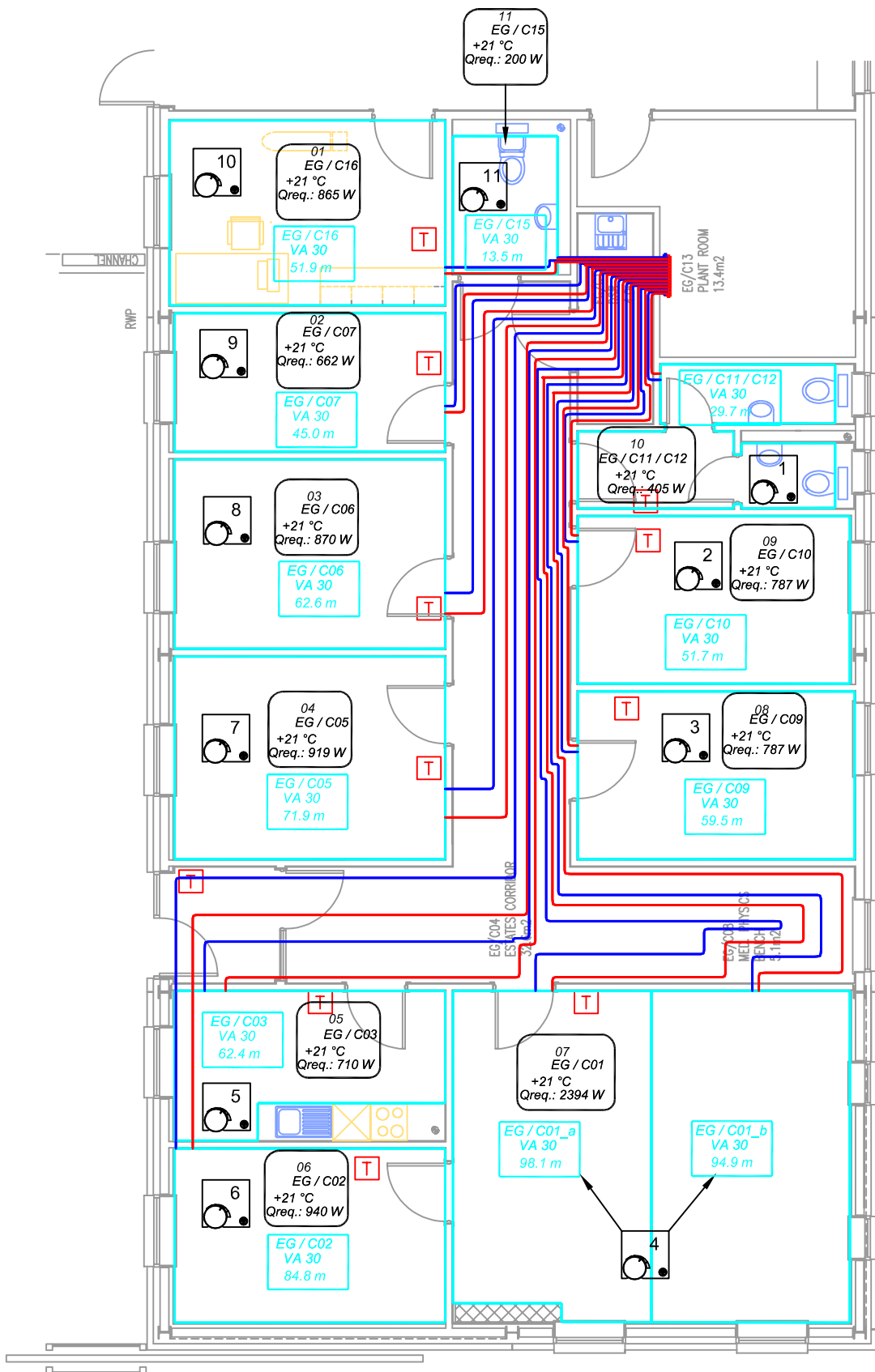

**TYPICAL EXAMPLE (SEE Figure 5a)**

**SEE velta PROJECT SPECIFIC DRAWING FOR RELEVANT LAYOUT.**

Figure 5b.

# velta MANIFOLD & GRUNDFOS PUMPING STATION

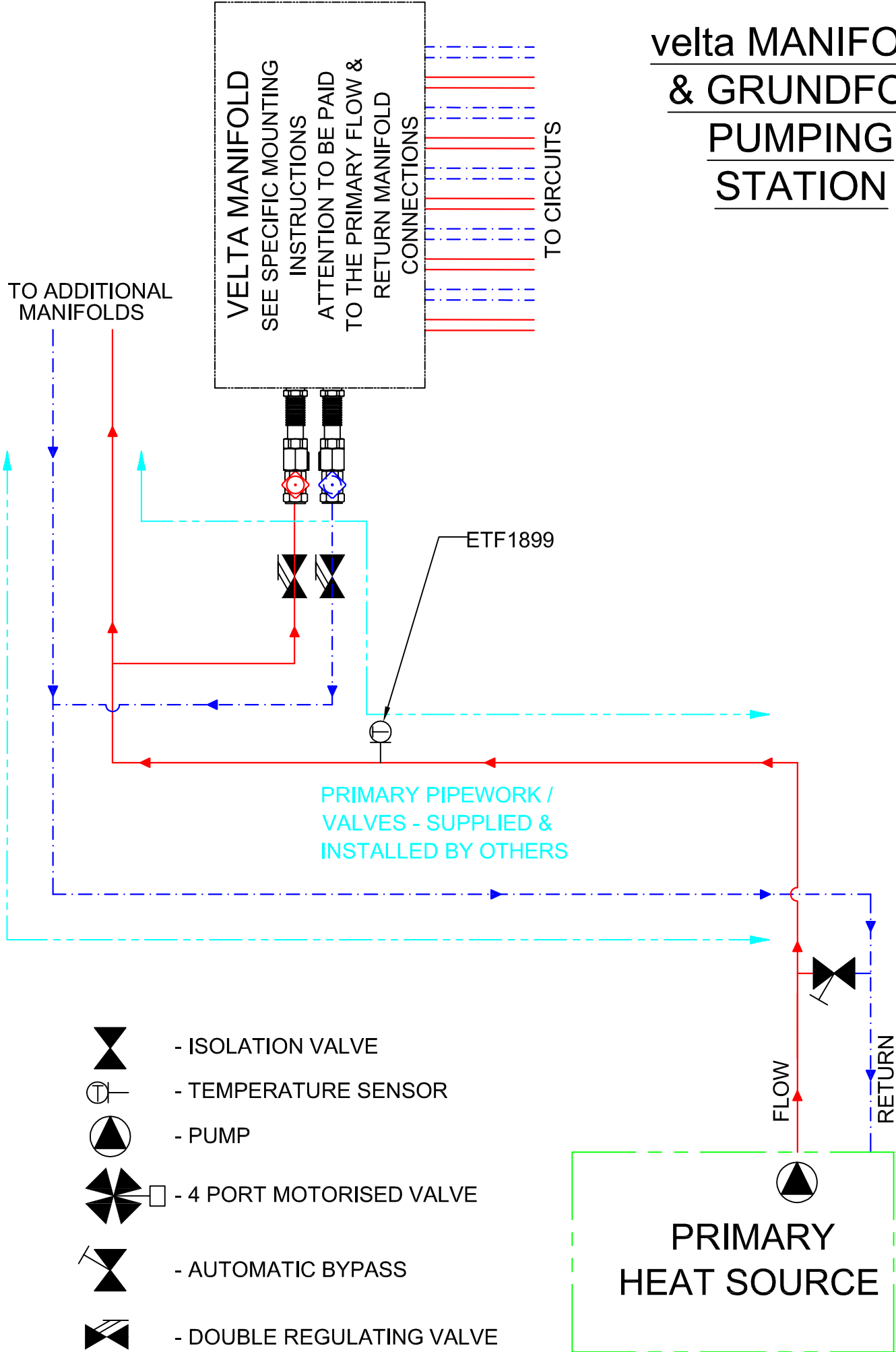

- ISOLATION VALVE
- TEMPERATURE SENSOR
- PUMP
- 4 PORT MOTORISED VALVE
- AUTOMATIC BYPASS
- DOUBLE REGULATING VALVE

Figure 6.

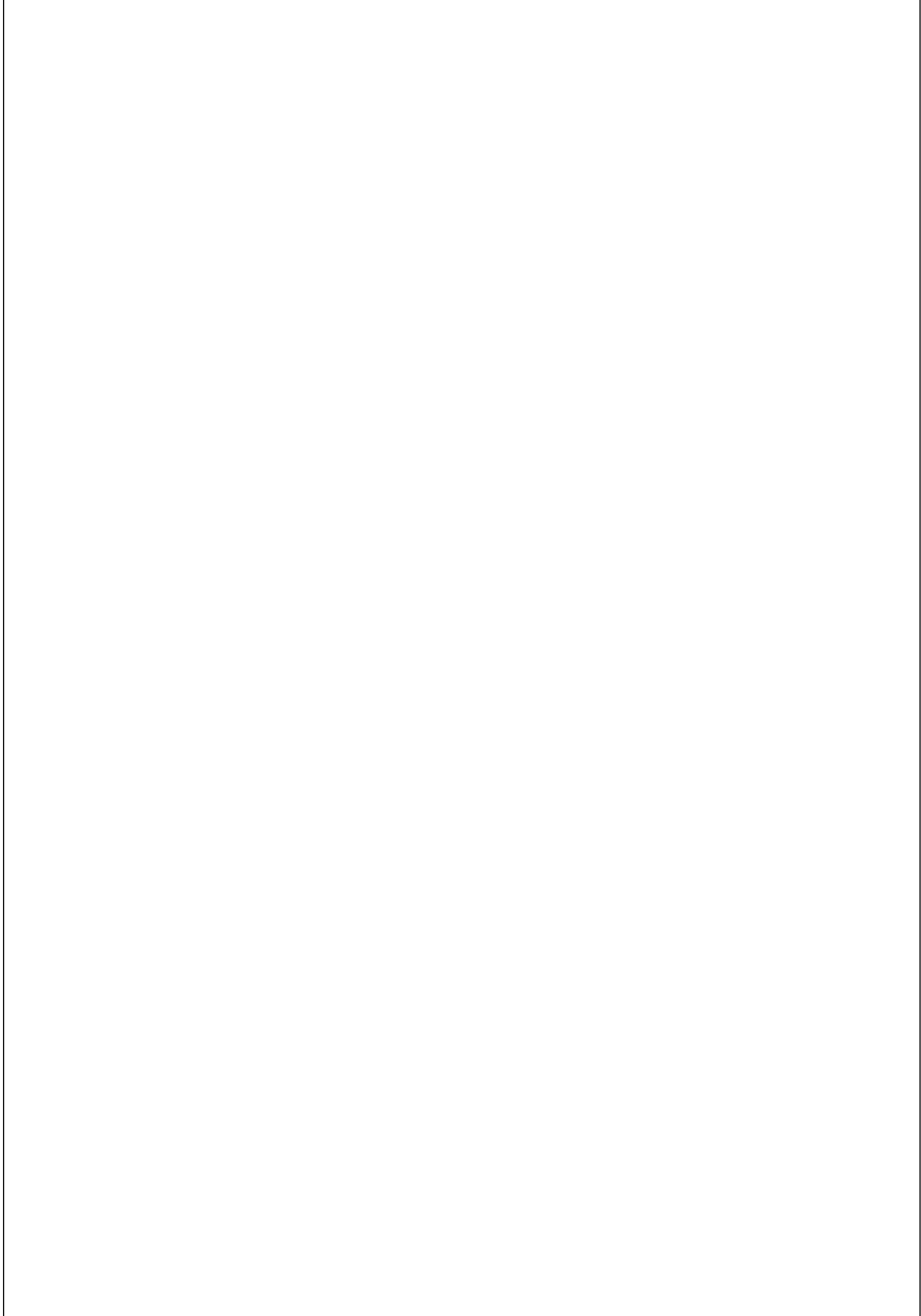



**The Under floor Heating Company Limited  
Unit 1 Skelmanthorpe Technology Park,  
Station Road,  
Skelmanthorpe,  
Huddersfield HD8 9GA  
T- 01484 860811 F- 01484 865775  
[www.velta-uk.com](http://www.velta-uk.com) info @velta-uk.com**