

Uponor

Uponor MLC Press-fit

Pipe system for heating, hot water and cold water services

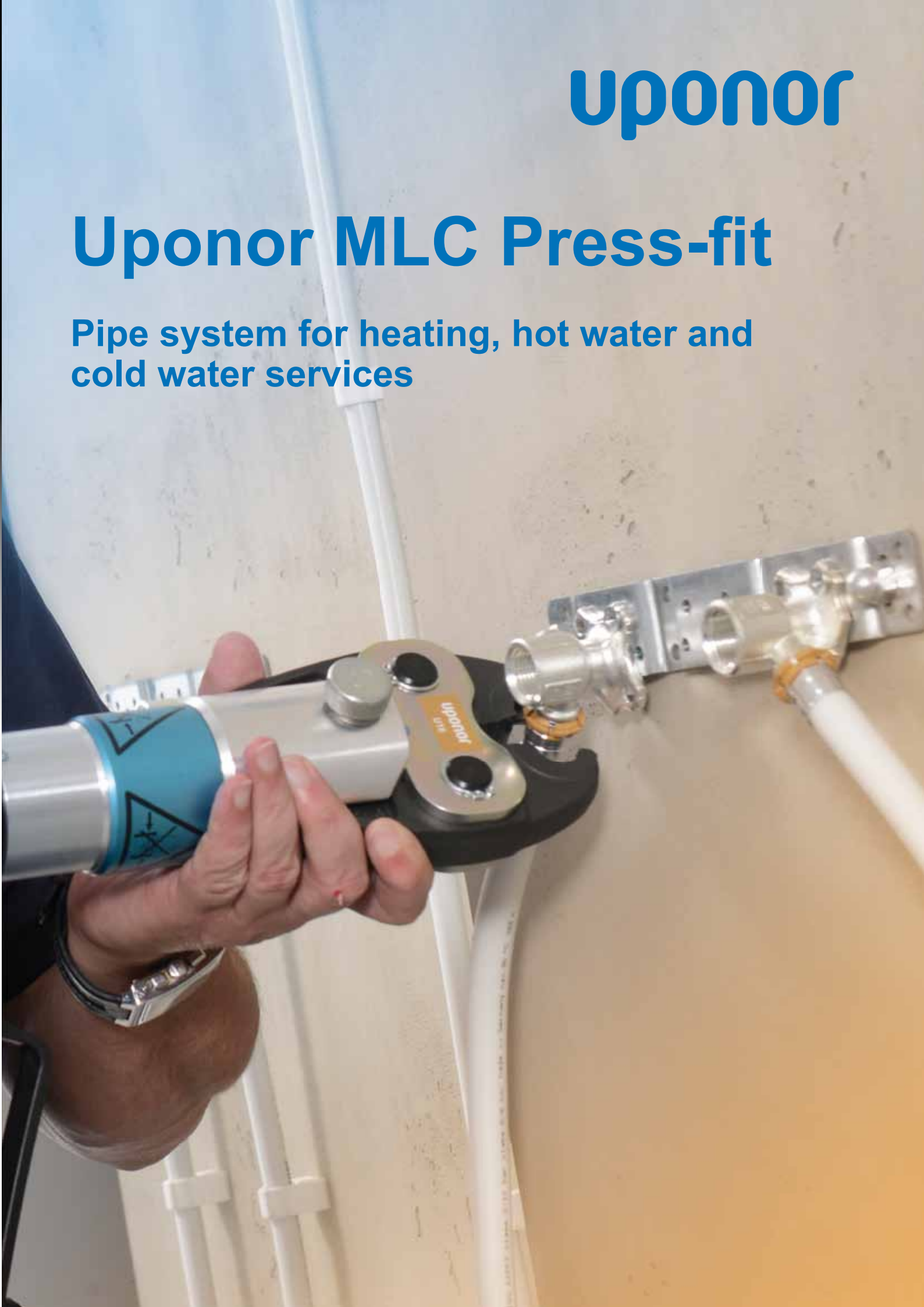



**Hello MLC
Goodbye copper.**

**The multi-layered plumbing
system with multiple benefits**

The Uponor MLC Press-Fit	4	Heating	39
The Uponor MLC Press-Fit Pipe	6	Radiator connection with the Uponor MLC system	39
5 layers – built for the future	6	Use of trace heating	39
Overview	8	Connection variations with MLC system	40
The Uponor MLC System	8	Planning basis for radiator connection	41
Recycling at Uponor	10	Fields of application	41
Design	11	Installation possibilities	
Technical notes on the Uponor MLC system	11	– Double-pipe heating system	42
Fire protection	11	Radiator manifolds	43
Thermal protection	12	NV manifold	43
Electrical earth bonding	14	LS manifold with radio controls	43
Consideration of thermal length variation	16	Calculation example	44
Plumbing manifolds	19	Calculation basis for radiator connection	45
Fittings for the Uponor Multi Layer Composite Pipe System	20	- Cold water flow pipe sizing tables	45
Test reliability is built-in at the factory	23	- Hot water flow pipe sizing tables	49
The Uponor MLC Click-Fit	24	Calculations for the Uponor MLC system	53
The Uponor MLC Press-Fit	26	Installation	54
Technical data and delivery dimensions	30	Transport, storage and installation conditions	54
Comparison of inner and outer diameters of MLC and metal pipes	31	Compatibility list Uponor pressing jaws/external pressing tools	55
Zeta values and equivalent pipe lengths	32	Installation dimensions	56
Tap Water Design	33	Installation method by Z-dimension	57
The Uponor MLC system used in tap water installation	33	Bending the Uponor MLC pipes	58
Protection of tap water	34	Pipe installation onto the raw floor	59
Connection to water heater, hot water tank and mixer	34	Pipe routing beneath solid floors	60
Planning basis for tap water installation	35	Notching and drilling joists	61
Smart End Elbow range	36	Mounting Instructions	62
Installation variations	37	Commision	70
		Pressure testing the tap water installation	70
		Pipe line flushing	72
		Pressure test for radiator installation	73

All legal and technical information in this publication was compiled carefully to the best of our knowledge. Nevertheless errors cannot be ruled out completely and we accept no liability for same.

All parts of this manual are protected by copyright. Any use beyond the exceptions permitted by copyright law is prohibited without the express permission of Uponor Limited (UK & Ireland). In particular, we reserve the rights to all duplications, re-printing, adaptation, electronic data processing and storage, translation and microfilming. Subject to technical modifications.

MLC Press Fit

The multi-layered plumbing system with multiple benefits

MLC Press-Fit is the most widely used alternative to copper piping in the UK market place because it's faster, cleaner, more cost-effective and more secure. Consequently, there's no better way to fast-track efficiently executed, watertight plumbing installations.

MLC is just like copper... only better. It's the definitive multi-layered plumbing system with multiple benefits and here are just a few of them:

Designed to deliver fast and clean installations

Easy to bend. Just cut to length and press to fit a guaranteed, secure connection. 'Head to head' speed tests have proved that it's faster... and easier.



Designed to last

It's corrosion and incrustation-free. The five-layer composite pipe has a diffusion-tight aluminium core layer that prevents the ingress of oxygen.

Designed for fewer connections

The inherent stability of the pipe and the low linear expansion, only a few fixing points are necessary. This delivers a highly practical advantage for a safe and fast installation.

Designed for inherent flexibility

Perfect for any application where copper pipes might be used. Used worldwide for commercial and domestic applications. Available in the widest range of sizes 16 - 110mm.

Designed to make 'your life easier'

It's not only simple, easy and fast to use... MLC Press-Fit also offers the full support and extensive back-up that you'd expect from a major brand and market leader. Training, comprehensive instructions and technical advice.



See just how fast!



The MLC Press-Fit pipe

5 layers - built for the future

With our 5 layer composite pipe we developed a product with a future, which combines the benefits of both metal and plastic pipes. Product benefits are obtained that cannot be surpassed: The inner aluminium layer provides a 100% oxygen proof barrier. It compensates for the snap-back forces and the linear expansion caused by temperature changes. The basis of the system is simple, safe and fast pipe installation: simply bend by hand, cut to length, bevel, join together, press - done!

The Uponor MLC Press-Fit pipe consists of a longitudinal safety overlap welded aluminium pipe, to which an inner and outer layer of high temperature resistant polyethylene is applied (in accordance with DIN 16833). All layers are permanently bounded together by means of an intermediate adhesive layer.

A special welding technique guarantees a maximum of safety. The thickness of the aluminium selected for the Uponor MLC Press-Fit pipe is exactly adapted to the compressive strength requirements as well as the bending capability confident that you're installing tried and tested, certified quality. Our system technology is safe and long lasting, certified by numerous tests and licenses.

The best installation: The Uponor MLC Press-Fit pipe for tap water installation and radiator connection can also be ordered pre-insulated (up to 25mm). You have an assortment available in sizes from 16-110 mm.

The pre-insulated pipes save installation time because the time intensive insulation of the mounted pipes and the resulting gluing of joints are eliminated.



Low linear expansion

Low weight

Easy handling

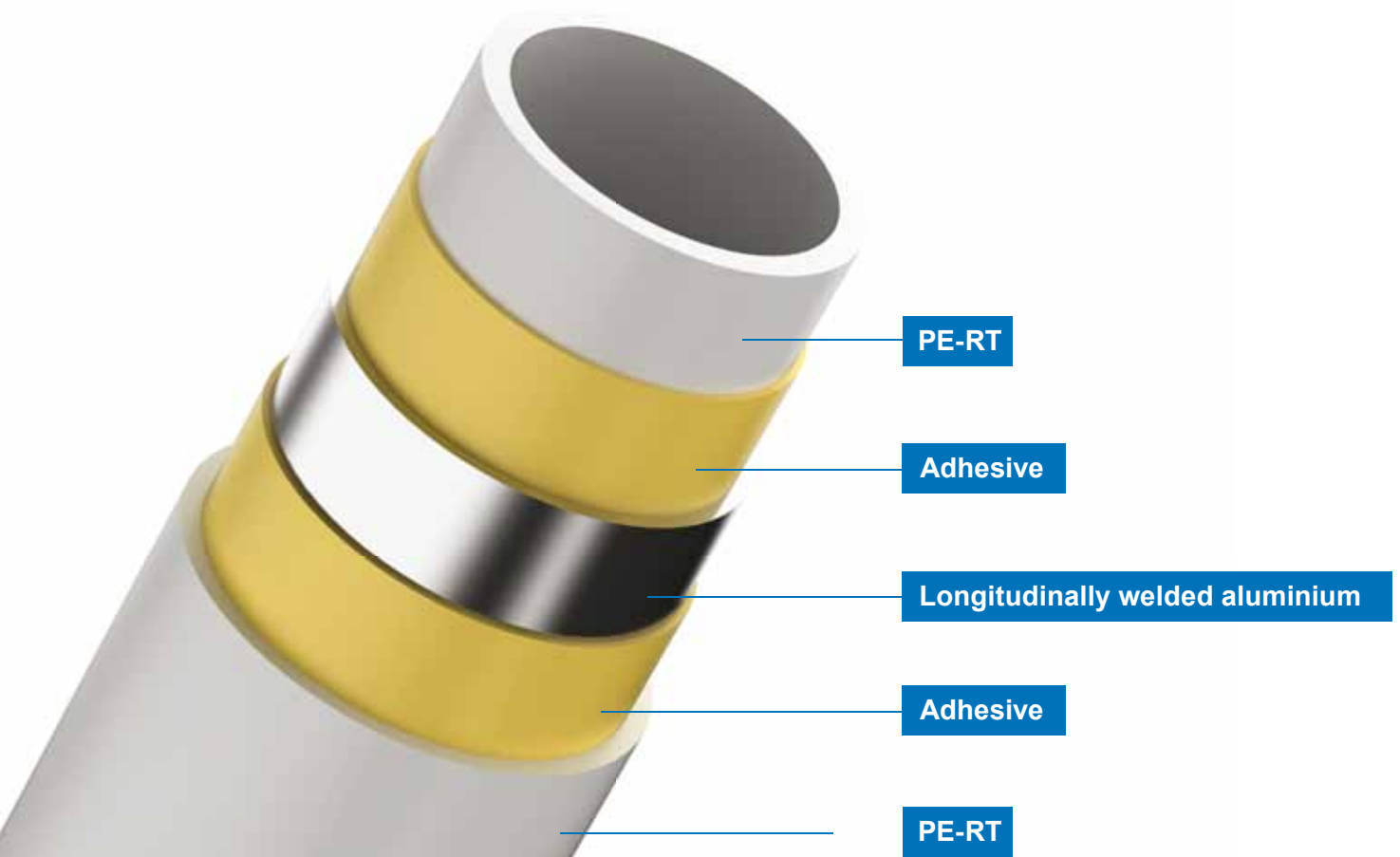

PE-RT

Adhesive

Longitudinally welded aluminium

Adhesive

PE-RT

High inherent stability and bend flexibility

Available in dimensions 16-110mm

Corrosion resistance

Excellent hydrostatic stress performance

Absolutely oxygen diffusion tight multi-layer composite pipe

Overview

The Uponor MLC system

Basis for your professional installation

Permanently watertight, together with a long service life, are the most important requirements that are demanded today from a reliable and high-quality installation. Uponor, as a leading manufacturer of plastic pipes for house construction and municipal technology fulfils these requirements without reservation with its Uponor MLC system. With this system we offer you the security that is so important for your installation.

The complete system from one source

Whether it is tap water, radiator connection or underfloor heating applications – the Uponor MLC system is the perfect solution. The installation is simple and economical: The core of the system, i.e. the Uponor MLC Pipe and the relevant fittings, are manufactured in house and therefore perfectly

coordinated. Through the inherent stability of the pipe and the low linear expansion, only a few fixing points are necessary – the practical advantage for a safe and fast installation. The Uponor MLC system is rounded off by a well thought out Tool program: from pipe cutting tool to bevelling tool to pressing tools.

Tested Quality

With the Uponor MLC system you install tested and certified quality. The system technology is safe and long lasting, certified by numerous tests and licences.





Recycling at Uponor



Nowadays technical demanding products no longer place a load on the environment. Uponor MLC, the modern multi-layer pipe system has been designed to the maximum environment compatibility in production.

Of course the recycling capability of the products is, in this respect, also an essential factor. In order for you, as customer, to rely on this, we have been working as a certified enterprise strictly according to the ISO 14001.

The fitting production

A closed raw material cycle has been created in fitting production. During different phases of operation all raw and operating materials are used in such a way, that they can be recycled by individual type, i.e. all chips and trims of brass material are collected and melted.

The cycle for drill and purifying agents is observed at every working step. Thus economic handling with valuable raw materials has been created to manifest itself in the production efficiency.

The pipe production

In pipe production an overall concept for recycling of discards and production waste exists at Uponor. Regarding the structure of the different plastic and aluminum layers separation becomes necessary in order to reuse every individual material according to its particular type.

The separation of plastics and aluminum is effected by the ultrasonic acceleration process. By an electrostatic purifying process aluminum and plastics with a high purity are gained.

The decisive aspect of the solely mechanical process: No environmental load due to chemical additives or other kinds of contamination!

The aluminum, as well as the part of unvulcanized polyethylene, can again be added to the raw material cycle as good as new. Vulcanized polyethylene has, due to its chemical structure, a special status: This resin is not any longer thermally moldable and is used in injection molding as filler or as fuel replacement for the cement and tyre industry.

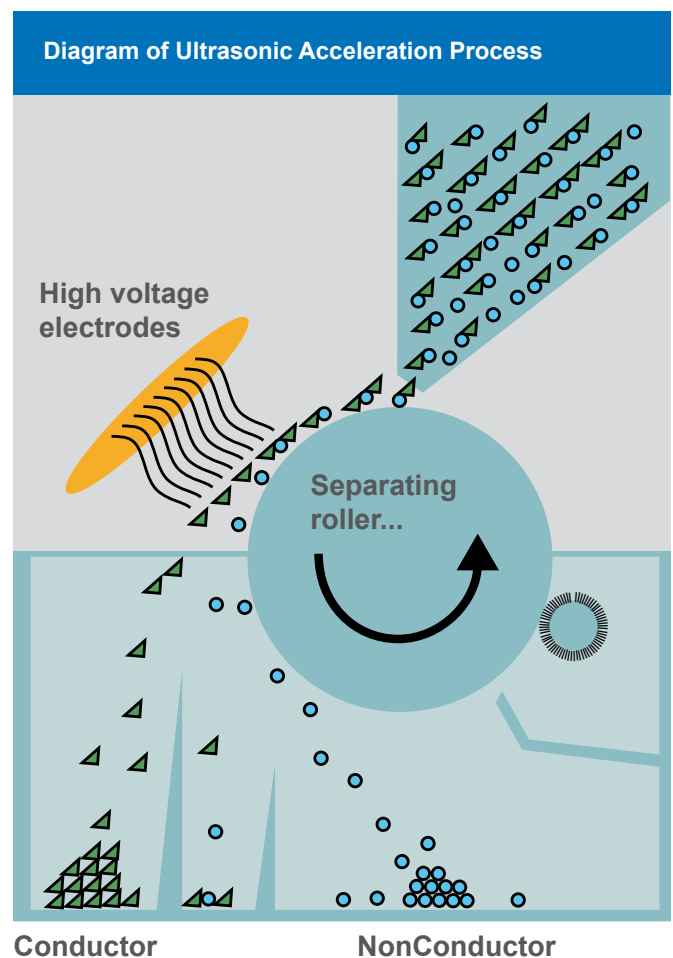

Design

Technical notes on the Uponor MLC system

Fire protection

The main goal of fire protection is to hinder fires. If a fire occurs, then the second goal of fire protection is to minimize damage. In the context of building legislation the Government establishes the preconditions in order to ensure public safety and prevent danger from destructive fires.

Pipes that pass through firewalls and stairwells, as well as walls and ceilings that must meet fire resistance grading, may only be installed if spreading of fire or smoke is not a risk or if provisions have been taken against such possibilities.

For example, when installing Uponor MLC pipes (building material class B2 in accordance with DIN 4102) with an outside diameter $OD \leq 32$ mm spreading of fire and smoke is not a risk if the area between pipe and the remaining cross-section of the opening is completely filled in with non-combustible, shape-retaining building material (closing the cut-outs with mortar and concrete).

If mineral fibres are used, they must have a melting point of more than 1000°C. In residential buildings the following basic fire protection principles apply:

- Along with the fire protection requirements, sound and thermal protection requirements as well as the thermal expansion/contraction of pipe systems must be considered when installing pipes through openings in walls or ceilings.
- Fires and smoke may not spread into other ventilation zones within the required fire resistance grading (e.g. F 90 = 90 minutes).
- All building materials must fulfil the building material class B2 = normal inflammable.

The high requirements of a fire prevention concept that guarantees health and life can only be realized with the cooperation of all parties taking part in the building project and with a tender and a construction supervision that is matched to the project.



Thermal protection

Even though MLC pipe has better insulation properties when compared with bare copper or steel pipes, for practical reasons we recommend that MLC pipe is installed to the same level as an equivalent sized metal pipe.

Building Regulations Part L 2013¹) and supporting compliance documents²) together with the Thermal Insulation Manufacturers and Suppliers Guide³) contains detailed information regarding standards that need to be achieved for frost protection and energy conservation purposes. While maximum pipeline heat losses should be calculated according to BS EN ISO 12241:2010.

1) Building Regulations Part L 2013 includes the following documents:

AD L1A Conservation of fuel and power in new dwellings (2006)

AD L1B Conservation of fuel and power in existing dwellings (2006)

AD L2A Conservation of fuel and power in new buildings other than dwellings (2006)

AD L2B Conservation of fuel and power in existing buildings other than dwellings (2006)

2) Compliance documents are:

The Domestic Heating Compliance Guide (2006)

The Non-domestic Heating, Cooling and Ventilation Compliance Guide (2006)

3) TIMSA Guidance for complying with Part L of the Building Regulations

Insulating solutions with pre-insulated Uponor Unipipe MLC pipes

Pre-insulated pipes are available for the Uponor MLC system in order to be able to meet the requirements of the Building Regulations during installation.

These pipes enable a time saving installation as the time intensive insulation and the gluing together of joints on the building site is not necessary. Due to its PE film covering, the pre-insulated Uponor MLC pipe is able to withstand the mechanical loads they are subject to on the building site.

Pre-insulated Uponor MLC pipes

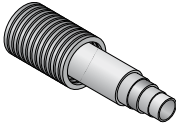
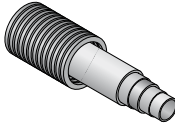
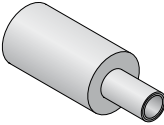
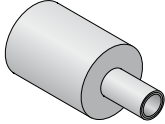
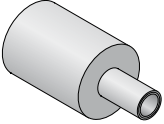
Insulation requirements	Sanitary	Heating
No requirements	 <p>Uponor MLC pipe in a protective tube* for dimensions 16 x 2 and 20 x 2.25 mm</p>	 <p>Uponor MLC pipe in a protective tube* for dimensions 16 x 2 and 20 x 2.25 mm</p>
9 mm thickness		 <p>Uponor UMLC insulated pipe S 9 mm for dimensions 16 x 2 and 20 x 2.25 mm</p>
13 mm thickness	 <p>Uponor MLC insulated pipe S 13 mm for dimensions 16 x 2, 20 x 2.25 and 25 x 2.5 mm</p>	 <p>Uponor MLC insulated pipe S 13 mm for dimensions 16 x 2, 20 x 2.25 and 25 x 2.5 mm</p>

Insulation of cold tap water pipes

Cold tap water systems are to be protected against an inadmissible temperature rise and, if necessary, against condensation. Cold tap water pipes are to be placed at a sufficient distance from heat sources. If this is not possible, then the pipes are to be insulated in such a way that the quality of the tap water is not impaired by a temperature rise.

With insufficiently insulated cold water pipes condensation can form on the insulating layer and other materials can become saturated. Therefore closed-cell or comparable materials with a high water vapour diffusion resistance should be used. All joints, cuts, seams, and end points are to be vapour sealed.

The following table shows recommended minimum insulating layer thicknesses, using an insulating layer heat conductivity of 0.040 W/(m × K). Specifications in the table for the protection against condensation formation on the outer insulating material surface can be used on the assumption of a tap water temperature of 10 °C.

If the pipe has a suitable covering (e.g. in a protective tube), protection from condensation formation is not required.

Pre-insulated Uponor MLC pipes

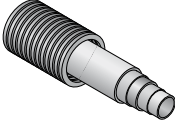
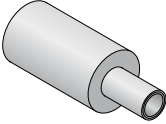
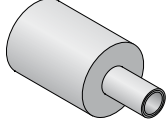
Installation situation	Thickness of insulating layer $\lambda = 0.040 \text{ W}/(\text{m} \times \text{K})$	Solutions with Uponor
Pipes laid open in a non heated area (e.g. Cellar)	-	
Pipes in a channel without warm water pipes	-	
Pipes in a wall slot, house connection lines	-	
Pipes on a concrete floor	-	Uponor MLC pipe in a protective tube for dimensions 16 x 2 and 20 x 2.25 mm
Pipes laid open in a heated area	9 mm	
Pipes laid directly below ceiling or roof void insulation	9 mm	
Pipes alongside warm water pipes	13 mm	
Pipes in wall recesses alongside warm water pipes	13 mm	
		Uponor MLC insulated pipe S 13 mm for dimensions 16 x 2 and 20 x 2.25 mm

Electrical earth bonding

Equipotential bonding is required between all types of protective conductors and the “conductive” water, waste water and heating pipes. Since an Uponor MLC pipe is a non-conductive pipe it cannot be used for equipotential bonding and should not be grounded. If Uponor MLC is used throughout the property for hot, cold and heating pipe work - and the incoming mains water is in plastic – then radiators and other metal components would not normally need earth bonding. Supplementary bonding of electrical appliances in bath/shower rooms will be necessary. However, it will not be needed for metal taps, towel rails or baths; unless the fitting is connected to a metal part of the building structure. For most new builds this will reduce the requirement for earth bonding work when compared with a traditional copper system.

The installer or construction supervisor has to point out to the client or their agent that a certified electrician must check whether or not the Uponor installation impairs the existing electrical protection and grounding measures.

NHBC Standards for detecting concealed pipes

NHBC Standards Chapter 8.1 ‘Internal Services’ Clause S” states that concealed pipework installed just behind a wall surface must be detectable, to enable the pipe to be easily located in the event of damage causing water leakage. This means that plastic pipes will need to be wrapped in a metallic tape when concealed to aid identification. As Uponor MLC pipe already incorporates an aluminium layer it is readily located with a cable/metal detector, and therefore does not need the addition of metallic tape.

Vermin Damage

Uponor MLC pipe and fittings do not attract vermin and, to date, we have not had a single reported case of damage due

to vermin attack. However, it is not unknown for rodents to gnaw plastic pipes and PVC cables. As Vermin can carry diseases, buildings should be constructed and maintained to preclude their presence.

Repair or renovation work

In the past different variations of the Uponor MLC Pipe were delivered.

- Red Unipipe F composite pipe (PE-MD/AL/PE-MD) for underfloor heating installation
- Brown Unipipe S composite pipe (PE-X/AL/PE-X) for tap water installation
- White Unipipe H composite pipe (PE-X/AL/PE-X) for heating installation

Since the beginning of 1997 the white Uponor Unipipe MLC pipe (PE-RT/AL/PE-RT) has been delivered for all applications (tap water, heating and radiant heating installation).

All of our latest product information refers to Uponor MLC (Multi-Layer Composite pipe), which has superseded the old Unipipe brand name. If older Uponor MLC pipes are to be extended or repaired, the Uponor MLC press repair coupling offers the possibility of changing to the current Uponor MLC pipe. The repair coupling is available in the dimensions 25, 32 and 40. The inner insert part extended on one side of the coupling also simplifies joining of the pipe ends to lack of space.

Moreover with the smaller dimensions up to 32mm the transition of existing to new installations is also possible using the composite press couplings or up to dimension 25 with screw connections in combination with double nipples. Standard fittings with a stainless steel press sleeve can be used with pipe fittings starting from dimension 50mm.

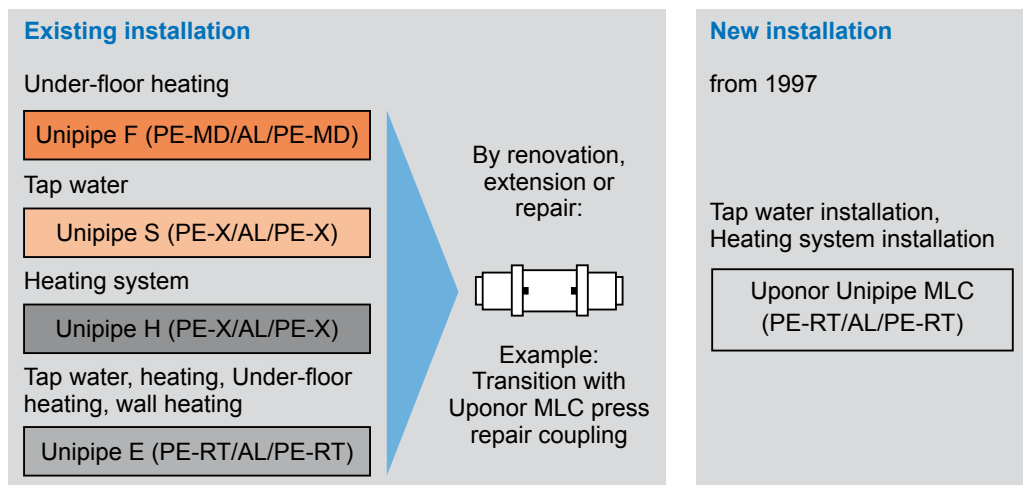

Outer corrosion protection of Uponor fittings

Because of the external corrosion protection there are no restrictions for mixed installation with other installation systems. The generally accepted rules of technology are to be complied with.

In view of the surface corrosion protection, MLC fittings can be installed directly in concrete, screed or under plaster. Although subject to location and accessibility of water fittings in accordance with Water Regulation (UK) and Water Bylaws (Scotland) guidelines.

However, there are some circumstances where protection from metallic connections or metallic components that come into direct contact with building materials is required, these are the combination of:

- Permanent or long-lasting moisture penetration and
- A pH value greater than 12.5.

In this situation we recommend a suitable covering for the Uponor MLC fittings such as insulating tape or shrink sleeve. Independent of the corrosion protection of the mouldings, all legal requirements and relevant standards for the respective application, particularly from the stand-point of thermal insulation and sound decoupling, must be adhered to.

Before applying the insulation the prescribed pressure test is to be run.

Threaded connection handling instructions

The thread sealants must have been tested and approved for the respective application. The sealants must be used according to their manufacturer's instructions. Uponor MLC press fittings may only be coupled with standard screw threads (BS EN 10226).

The threaded connection must be made before pressing so that no stress is placed on the press fitting connection. The threaded connections must be made properly in accordance with the generally accepted rules of technology. No undue force may be used when working with brass components. Excessive thread sealant (e.g. excessive hemp packing) at the threaded connections must be avoided.

The following points must be observed when making threaded connections:

- Excessive tightening of the threaded connection can result in damage to the material; suitable tools must be used.
- The installation tools may not be lengthened to increase the force when tightening a connection (e.g. by attaching pipes),
- All the materials and auxiliary materials used (e.g. sealants, installation material and cleaners) must be free of substances that can cause stress corrosion cracking (e.g. compounds containing ammonia or chloride).



Caution!

For tap water installations, sealants must be authorized and certified by WRAS.

Consideration of the thermal length variation

The thermal length variations, that result due to changing temperatures, must be considered when designing pipe routes. Temperature difference Δt and the pipe length L play a decisive role in the length variation.

For all installation variations the heat expansion of Uponor MLC pipes must be considered in order to avoid excessive stress in the pipe material and damage to the connections, in particular at branch and end connections. For pipes that are laid in the wall under plaster or in the screed, the heat expansion is compensated for by the insulation in the area of direction change.

The following equation is used to calculate the length variation:

$$\Delta l = \alpha \times L \times \Delta t$$

Here:

Δl : Heat expansion (mm)

α : Linear expansion coefficient
(0.025 mm/(m × K))

L : Pipe length (m)

Δt : Temperature difference (K)

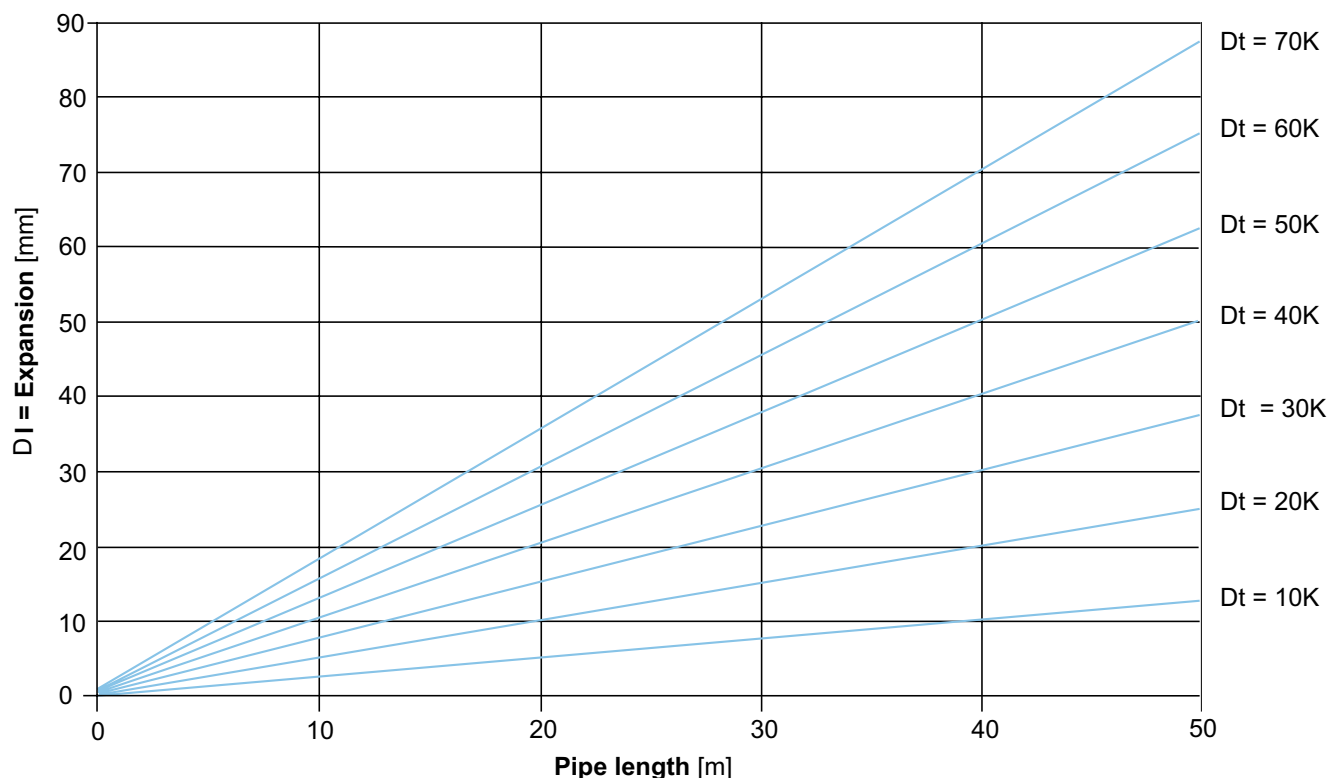

Main distribution lines

When planning and installing main distribution pipe lines using the Uponor MLC system, along with the structural requirements, thermally caused linear expansions must be considered.

Uponor MLC pipes may not be installed rigidly between two fixed points. You must always compensate for the length variation of the pipes.

Open laid Uponor MLC pipes that are fully exposed to thermal expansion must be provided with suitable compensation for expansion and contraction. For this you need to know the location of all fixed points. Compensation is always provided between two fixed points (FP) and changes of direction (bending shank BS).

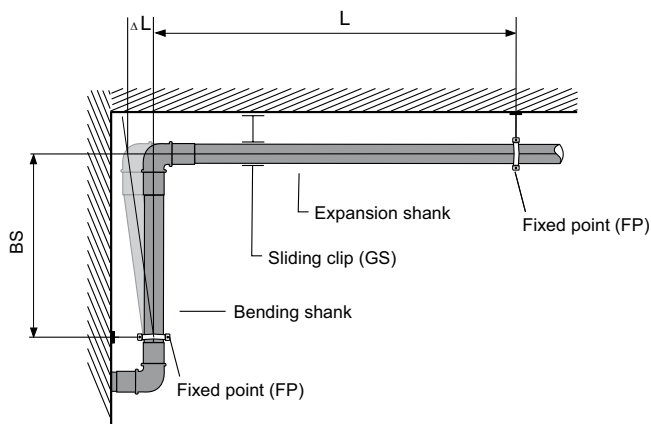

Determination of the bending shank length

Graphic determination of the required bending shank length

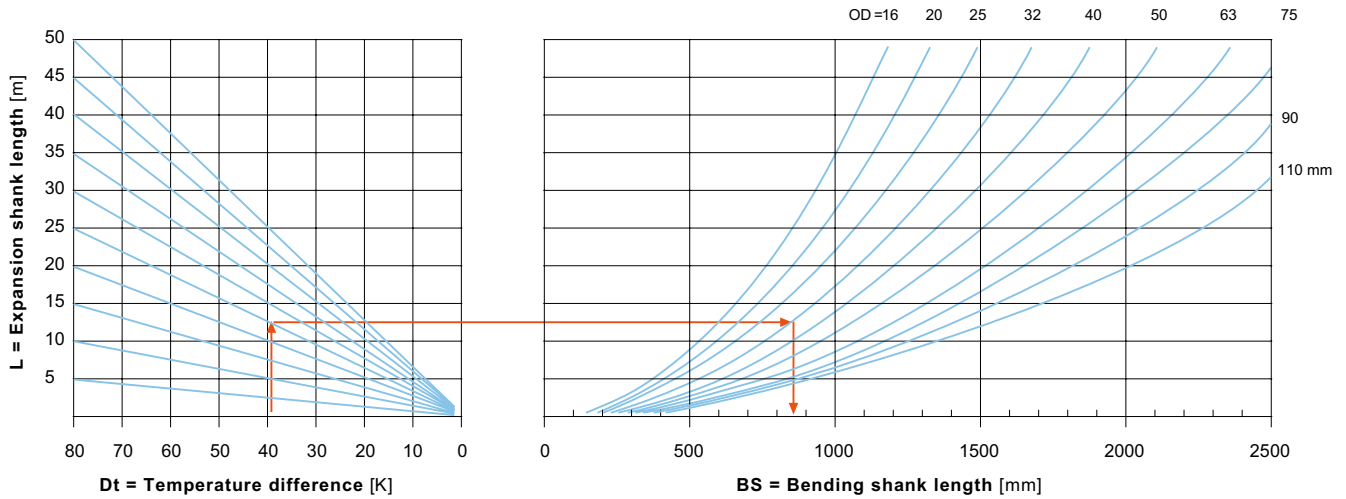

Readout example

Installation temperature:	20 °C
Operating temperature:	60 °C
Temperature difference Δt :	40 K
Expansion shank length:	25 m
Pipe dimensions OD x s:	32 x 3 mm
Necessary bending shank length BS:	approx. 850 mm

Calculation formula:

$$BS = k \times \sqrt{OD \times (\Delta t \times \alpha \times L)}$$

OD = Pipe outer diameter in mm

L = Expansion shank length in m

BS = Bending shank length in mm

α = Linear expansion coefficient (0.025 mm/(mm x K))

Δt = Temperature difference in K

k = 30 (Material constant)

Comprehensive installer, design and control courses available at the Uponor Training Academy.

● **UFH Installer Course**

A one-day course at our purpose-built facility in Watford. The course is aimed at both new and experienced users of our products. Day 1 gives a thorough understanding of applications of UFH in our theory suite.

● **Merchant Course**

- A course which gives an overview of Uponor products and their applications. Mainly aimed at Merchants but can be specifically tailored to give a bespoke course for installers, or anyone who requires specific guidance in the application of UFH or Plumbing. Please contact us to discuss your requirements.

All courses include:

- * Course Materials
- * Uponor delegate packs
- * Exclusive 'on the day' Tool Deals
- * Lunch

- Visit www.uponor.co.uk to book a course at our Academy.

For special offers, please contact your local Uponor Sales Representative or follow us @uponorUK

All courses are held at our purpose built facility close to J5 M1, in the market town of Watford.

Uponor
simply more

Plumbing Manifolds

Uponor's range of plumbing manifolds includes the 'L' manifold, which is available in the standard ¾" size, or a larger size 1" manifold for higher flow rates. The 'L' manifold comes in 2, 3, and 4 port sizes and these can be easily screwed together to give a larger number of ports. They incorporate isolating service valves on each outlet for isolation of individual taps/appliances and have ½" (mt) outlets. For systems not requiring individual service valves at the manifold, we can supply the plain 1" manifold 'P', which also has ½" (mt) outlets and again comes in 2, 3, and 4 port sizes.

The Uponor MLC Pipe – a well thought out development

Benefits:

- Absolutely oxygen diffusion tight multi-layer composite pipe
- Available in dimensions 12 - 110 mm
- Easy handling
- Low weight
- High inherent stability and bend flexibility
- Low linear expansion
- Excellent hydrostatic stress performance
- Corrosion resistance

Construction of the Uponor MLC Pipe.

Note: 12mm MLC pipe has PE-X (cross-linked polyethylene) as opposed to PE-RT inner and outer layers

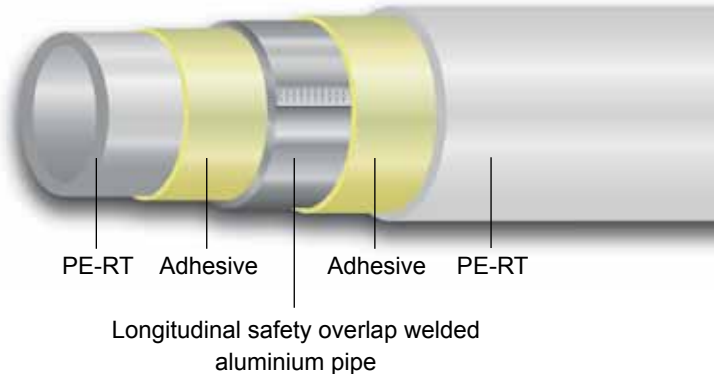

5 layers – built for the future

With our 5 layer composite pipe we developed a product with a future, which combines the benefits of both metal and plastic pipes.

Product benefits are obtained that cannot be surpassed:

The inner aluminium pipe is absolutely safe against oxygen penetration. It compensates for the snap-back forces and the linear expansion caused by temperature changes.

The basis of the system is simple, safe and fast pipe installation: simply bend by hand, cut to length, bevelling, join together, press – done!

The Uponor MLC pipe consists of a longitudinal safety overlap welded aluminium pipe, to which an inner and outer layer of high temperature resistant polyethylene is applied (in accordance with DIN 16833).

All layers are permanently bounded together by means of an intermediate adhesive layer.

A special welding technique guarantees a maximum of safety. The thickness of the aluminium selected for the Uponor MLC pipe is exactly adapted to the compressive strength requirements as well as the bending capability.

The best installation

The Uponor MLC pipe for tap water installation and radiator connection can also be ordered pre-insulated. You have an assortment available in sizes from 16-25 mm. The pre-insulated pipes save installation time because the time intensive insulation of the mounted pipes and the resulting gluing of joints are eliminated.

The resilience of the multi-layer composite pipe is checked regularly by tensile testing. Along with the continuous laboratory testing of the pipe, each Uponor MLC pipe is checked during production for accuracy of size and water tightness.

The Uponor MLC pipe has a comparatively low linear expansion due to the plastic film's firm bond to the aluminium

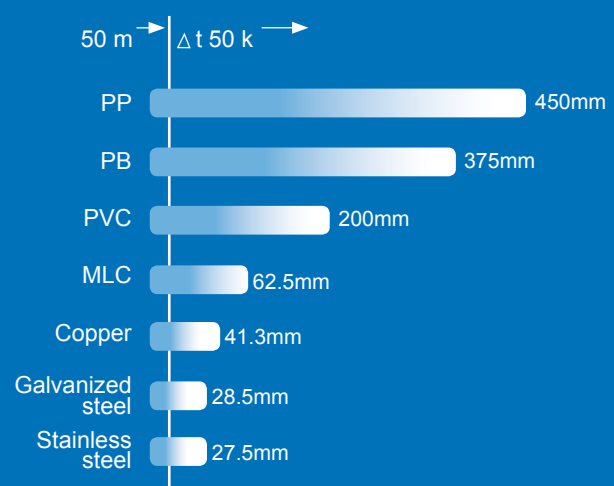

Fittings for the Uponor Multi Layer Composite Pipe System

Different fitting concepts – one Multi Layer Composite pipe

Uponor's strength is that it has developed and designed a fitting concept that exactly fits the pipes. With its couplings, elbows, tees and a large number of other highly practical system components, the range of fittings leaves nothing to be desired. Press, screw or RTM – whichever method you choose ensures long-lasting tight

connections. The flexibility of the multi-component pipe system means elbow bends can often be avoided. This cuts down on costs in terms of time and materials. Added advantages are the fact that the pipes needed for installation can be shorter and the installation is more secure. Whether for pressing or screwing, you are bound to find the right fitting in Uponor's extensive range of fittings, even for complex applications.

Uponor MLC press fittings

The patented Uponor press system means fittings can be made literally in seconds. Complex fitting techniques such as welding and soldering are no longer necessary. Fitting techniques such as pressing and screwing create joints which remain tight for a long time.

Test reports by the SKZ, the Süddeutsche Kunststoff-Zentrum (South German Plastics Centre), and certificates from the DVGW, the Deutscher Verein des Gas- und Wasserfaches e.V. (German Technical and Scientific Association for Gas and Water), WRAS UK.



Overview of multi-component pipe system and fittings for drinking water and heating installations

Pipe	MLC press fitting, test-proof, 'not pressed, not tight', pressed identification and colour coding Beveling	RTM fitting, with integrated press function, pressed identification and colour coding	MLC multi-component press, press fitting made of PPSU, 'not pressed not tight', pressed identification and colour coding	MLC modular fitting system for manifolds and risers	MLC Screw Size fitting,
*12 x 1,6	●	-	-	-	●
16 x 2	●	●	●	-	●
20 x 2,25	●	●	●	-	●
25 x 2,5	●	●	●	○	●
32 x 3	●	●	●	○	-
40 x 4	●	-	●	○	-
50 x 4,5	●	-	●	○	-
63 x 6	-	-	-	●	-
75 x 7,5	-	-	-	●	-
90 x 8,5	-	-	-	●	-
110 x 10	-	-	-	●	-

*12 x 1,6 pipe press fittings do not have colour coded stop rings



MLC modular fitting system, for manifolds and risers



MLC press fitting, test-proof, with coloured stop rings











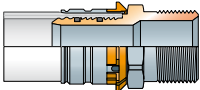
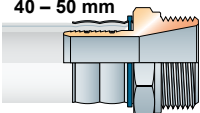









MLC composite fitting, test-proof, made of PPSU



RTM fitting with integrated press function

Uponor MLC press fitting with coloured stop rings

16 – 50 mm	Description/characteristics	Material												
<p>16 - 32 mm</p>  <p>40 – 50 mm</p> 	<ul style="list-style-type: none"> Firmly fixed press sleeve, permanently connected with the fitting body protects against mechanical damage to the O-ring Press sleeves with inspection windows, the penetration depth of the pipe into the fitting can be checked before pressing Coloured stop rings that break off during pressing (16 to 32mm) After installation the form-stable press sleeve allows the connection to absorb bending forces without developing leaks. This allows a pipe that has already been installed to be realigned after installation (up until the pressure test) 	<ul style="list-style-type: none"> Brass, tin plated Aluminium formed press sleeve (16 to 32mm) and stainless steel press sleeve (40 & 50mm) Coloured plastic stop rings <p>Dimension colour codes</p> <table border="0"> <tr> <td></td> <td>16mm</td> <td></td> <td>32mm</td> </tr> <tr> <td></td> <td>20mm</td> <td></td> <td>40mm</td> </tr> <tr> <td></td> <td>25mm</td> <td></td> <td>50mm</td> </tr> </table>		16mm		32mm		20mm		40mm		25mm		50mm
	16mm		32mm											
	20mm		40mm											
	25mm		50mm											



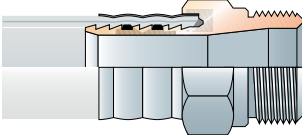



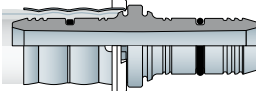
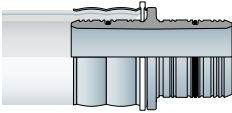



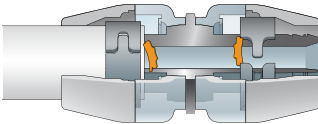

Uponor MLC press fittings

12 mm	Description/characteristics	Material
	<ul style="list-style-type: none"> Firmly fixed press sleeve, permanently connected with the fitting body protects against mechanical damage to the O-ring Press sleeves with inspection windows, the penetration depth of the pipe into the fitting can be checked before pressing After installation the form-stable press sleeve allows the connection to absorb bending forces without developing leaks. This allows a pipe that has already been installed to be realigned after installation (up until the pressure test) 	<ul style="list-style-type: none"> Brass, tin plated Stainless steel press sleeve











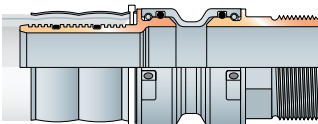

Uponor MLC composite press fittings

16 – 50 mm	Description/characteristics	Material
<p>16 – 32 mm</p>  <p>40 - 50 mm</p> 	<ul style="list-style-type: none"> During installation the Uponor MLC Pipe it is pushed between the supporting sleeve and stainless steel press sleeve and a force-closed connection is made with the Uponor composite fitting. Pressed into the inner plastic layer of the pipe, the special profile of the PPSU insert produces a reliable connection. A high-temperature and age resistant O-ring fitted into a groove provides sealing between the insert part and inner wall of the pipe. After installation the form-stable press sleeve allows the connection to absorb bending forces without developing leaks. This allows a pipe that has already been installed to be realigned after installation (up until the pressure test) 	<ul style="list-style-type: none"> High performance synthetic PPSU Stainless steel press sleeve

Uponor RTM MLC fittings with integrated press function and colour coding

16-32 mm	Description/properties	Material								
	<ul style="list-style-type: none"> One-piece fitting with integrated press function (Ring Tension Memory). Inserting the pipe end triggers the press function; no additional tools needed for pressing. 360° window and distinctive click make it easy to confirm the complete press. Safety lock, colour coded according to size. 	<ul style="list-style-type: none"> High-performance PPSU plastic Press ring made of high-strength, specially coated carbon steel <p>Colour code Size</p> <table border="0"> <tr> <td></td> <td>16</td> <td></td> <td>25</td> </tr> <tr> <td></td> <td></td> <td></td> <td>32</td> </tr> </table>		16		25				32
	16		25							
			32							

Uponor MLC fitting system for manifolds and risers (modular)

63-110 mm	Description/properties	Material								
	<ul style="list-style-type: none"> The MLC modular fitting system comprises a range of Tin-plated brass, base elements and press adapters that fit together. The press adapters with fixed press sleeves made of stainless steel can be conveniently pressed onto the Uponor composite pipes away from the installation position, e. g. at the workbench. In the second step the pre-mounted press adapters are inserted into the corresponding base elements on site and tightly fitted by means of a locking ring. 	<ul style="list-style-type: none"> Tin-plated brass, Stainless steel press sleeve <p>Colour code Size</p> <table border="0"> <tr> <td></td> <td>63</td> <td></td> <td>90</td> </tr> <tr> <td></td> <td></td> <td></td> <td>110</td> </tr> </table>		63		90				110
	63		90							
			110							

Uponor MLC screw fitting

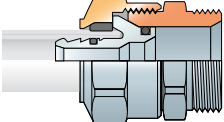
12 - 25 mm	Description/properties	Material
	<ul style="list-style-type: none"> The Uponor MLC screw fitting can be used for directly connecting Uponor multi-component pipes to 1/2" Uponor moulded components, manifolds and sanitary fittings. The 3/4" version can be fitted to 3/4" Eurocone moulded components. 	<ul style="list-style-type: none"> Brass-plated union nuts

Note: A range of MLC to copper compression fittings is also available.

Test reliability is built-in at the factory.

The Uponor MLC press fittings 16 – 32 mm

Metal MLC press fitting with coloured stop rings

The Uponor press fitting 16-32 mm is a new generation metal press fitting. Because here reliable testing is standard. The fitting is manufactured with optimized support sleeve geometry; a stop ring and press jaw guide ensures simple, skew free pressing. O-rings ensure an absolute watertight connection between the support sleeve and inner pipe wall. The system is certified by WRAS.

The installation friendly metal press fitting is designed in such a way that, during the prescribed pressure test, water leaks from the unpressed connections or the fitting separates from the pipe. That means, simply press and a durable and watertight connection is guaranteed.

Coloured stop rings on the installation friendly Uponor press fittings are the sign of the new Uponor fitting generation. Each nominal size from 16 to 32 mm has its own colour – this brings clarity to the building site, the warehouse as well as to the wholesaler.



1. Application

The press jaw is placed onto the **press guide** of the press sleeve.



2. Pressing

During the pressing procedure the stop ring breaks into pieces and falls off of the press sleeve.

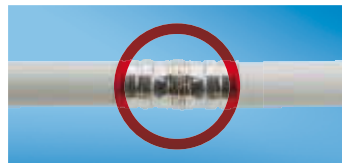

3. Testing

The missing stop rings reliably mark a successful connection. This can be recognized at a distance of many metres.

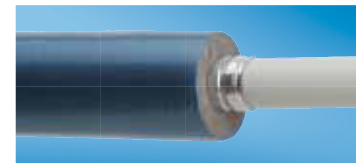

4. Insulation

Continuous pipe insulation such as Tubolit can be easily pushed over the obstacle-free connection.



If a connection is still not pressed, this is shown up doubly when pressing. The coloured stop rings are still attached. Additionally the fitting is designed in such a way that during the pressure test water leaks out. Now simply press and the connection is permanently tight.



Colour coded diameters

16

20

25

32

40

50

MLC Click-Fit

The revolutionary RTM™ fitting. No leaks. No tools. No equal.

MLC Click-Fit system comes with RTM™ Technology: Ring Tension Memory with the Tool-Inside concept, ideal for refurbishment and new buildings, allowing safe, quick and professional joints, thanks to the Joint Indicator and no tool dependence. RTM™ Technology works perfectly with Uponor's MLC pipes.

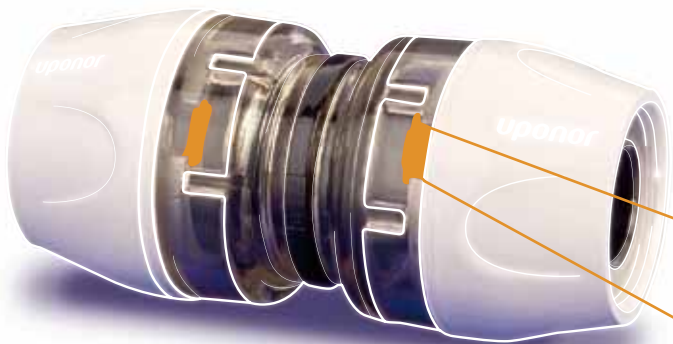

The highly technological materials used for the fitting combine ultra-light plastic with the best properties of metal, guaranteeing outstanding performance. The press ring is made of high-strength specially coated carbon steel.

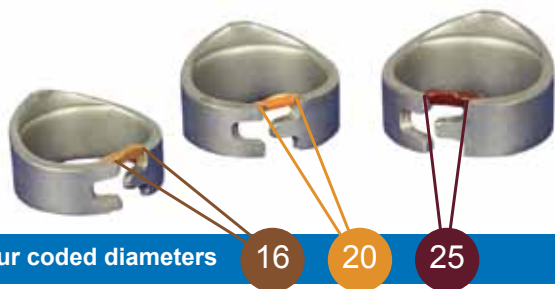

Colour coded diameters

16

20

25



Ring Tension Memory Technology

TOOL  **INSIDE**

Colour coding for sizes 16 to 25mm

Pressed identification with proven colour coding means the right sizes can be seen at a glance, which saves time and ensures a safe, reliable fitting.

Safety is paramount

One of our main aims is to maintain our very high safety standards in fitting technology. Like all our products RTM™ fitting technology has been subjected to the most stringent tests and exposed to the most extreme working conditions. In this way we can present fitting technology that meets all the latest test standards for drinking water installation and

withstands even abnormal loads such as pressure surges and any linear expansion in pipes due to temperature changes.

RTM™ technology with the TOOL INSIDE concept has WRAS and DVGW certification.

The integrated press function dispenses with the need for pressing tools.



Integrated press function

Inserting an Uponor composite pipe into the RTMTM fitting loosens the safety lock from the press ring. There is a distinctive click which signals successful fitting. Once loosened, the safety lock becomes visible in the 360° window. The lock fulfils three functions: it keeps the press ring at an optimum tension until the fitting is pressed, it is colour coded according to size and signals the end of the pressing process.



1 Fitting not yet pressed



2 Pipe inserted up to the click

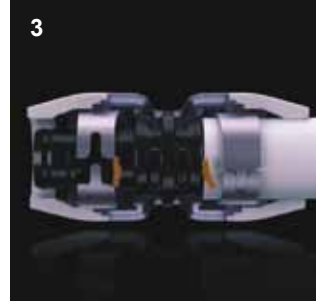

3 Fitting pressed

Fast, reliable fitting

To create a perfect fitting cut the Multi-component pipe off, calibrate the pipe* end and trigger the press function by inserting the pipe until you hear a click.



1 Cut



2 Calibrate



3 Press



*You must not bevel the pipe on an RTM fitting, as this can cause failure of the fitting.

MLC Press-Fit

Uponor Riser (Modular) System

The Uponor MLC Riser fitting system for manifolds and risers: flexible planning, reliable purchasing, easy installation

Faster planning with only 39 components

Conventional 63-110 mm installation systems require as many as 300 different components. The Uponor multi-component pipe system for manifolds and risers consists of a mere 39 – making your planning much easier. Despite the small number of components, the system can still cope with almost every conceivable task; moreover, fewer components means the system is clearer, allowing you the freedom to think of imaginative solutions.

Flexibility for changes of plan

If unexpected problems occur on site, which force you to change your plans, the 'press and lock' fitting technology allows you to respond flexibly. Fittings can always be unlocked, loosened and then put together again during installation. For safety reasons, it is not possible to remove the locking element when the system is under pressure.

Compact size transitions

In conventional systems several reducers often have to be coupled together, one after the other, when connecting pipes of different diameters. The Uponor multi-component pipe system for manifolds and risers performs this task with a single component – a much faster, more compact and more reliable solution.

Cost-effective logistics

Thanks to its few components the modular Uponor MLC fitting system for manifolds and risers is ideal for ensuring you will have all the components ready to hand at all times. Moreover, fewer components mean less investment is needed, lower administration costs and less space in the warehouse.

Nor are there any seldom-used special components; if a component is left over from a project, it can easily be used again in the next job. Delays caused by long delivery times, otherwise frequent with special fittings in particular, are therefore no longer an issue.



The plus points

- Just 39 system components in total makes hundreds of variations possible.
- New fitting concept comprising base elements and tin-plated brass adapters, which can be inserted into the former and fit perfectly. Innovative plug-in fitting between base elements and adapters.
- Greater flexibility and lower logistics costs thanks to minimal number of system components Optimum availability with less storage space and lower investment costs
- Quick to install if pressed at the workbench and assembled without tools on site
- The familiar UP 75 press machine now usable with sizes up to 110 mm.
- Easy to correct after changes of plan during installation
- Not possible to unlock fittings when system is under pressure.

Press – Insert – Lock

Until now press fittings often had to be done at considerable height and in confined spaces on site. Under these conditions handling pipe sections and heavy tools requires several people, increases the risk of accidents and does not always produce the best results.

The Uponor MLC riser fitting system for manifolds and risers allows you to carry out all the required press fittings in comfort and safety at the workbench. It is only at this stage that heavy tools are needed. Once on site the pre-mounted multi-component pipe sections can be inserted and locked into the fittings without tools. This guarantees fast, top-quality installations even in extremely confined spaces. Arduous work in cramped corners or above your head is a thing of the past.



Just four steps to the perfect fitting

The riser design of the system enables all the fittings to be performed in the same five steps. The only process that needs tools is pressing, which can be carried out conveniently at the workbench.

- 1 Simply insert the bevelled pipe in the press adapter.
- 2 Press the fitting.
- 3 Insert the press adapter into the base element.
- 4 Push the locking element into the opening of the fitting element and allow it to click into place.



Note: once a locking pin is used it cannot be reused.

Colour coded diameters

63

75

90

110



Maximum flexibility with just 39 components

The Uponor MLC 63-110 mm riser fitting system comprises few components, all made to fit together exactly. The available components fit all the sizes required in any customized multi-component pipe installations.

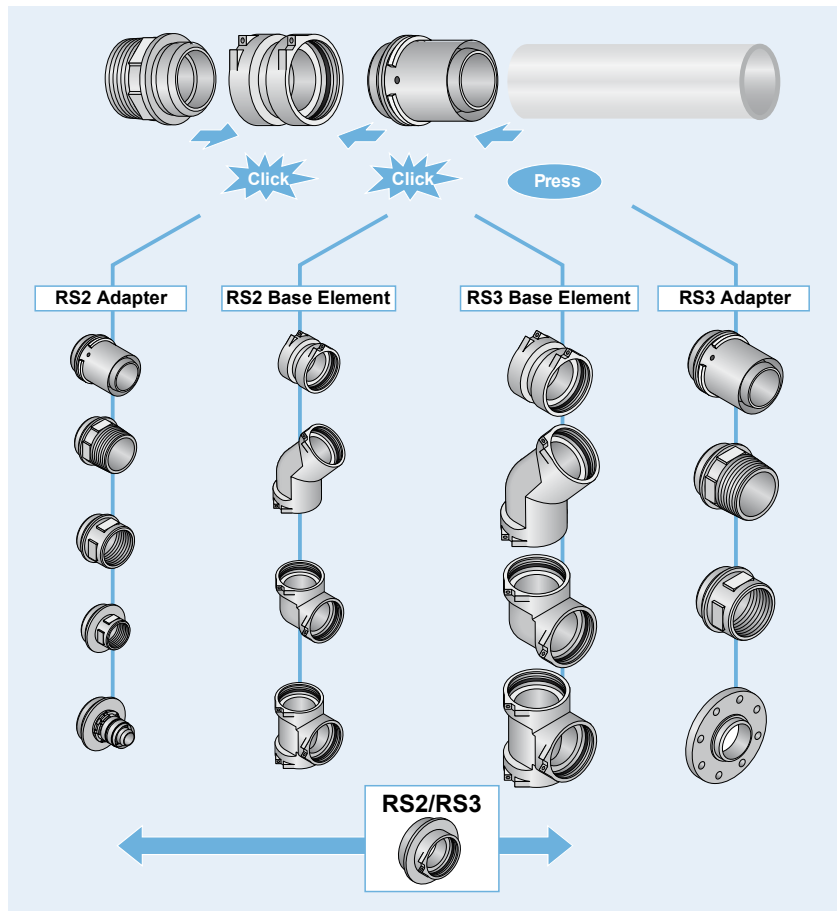

Tee with ports

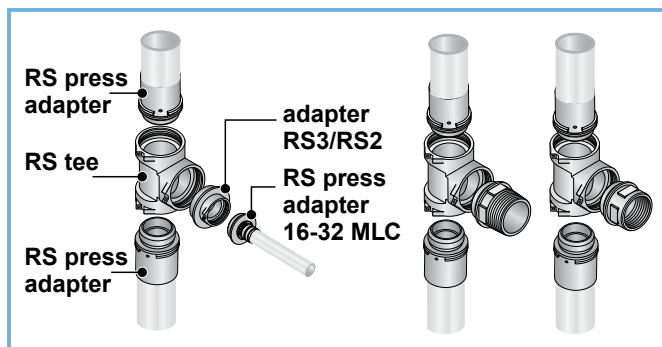

90° or 45° elbow

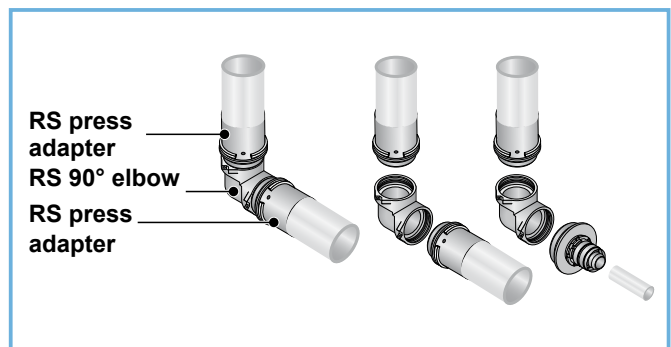

Transitions as required

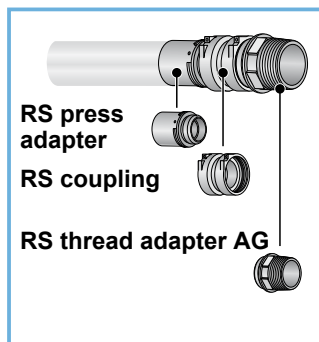

Transitions as required

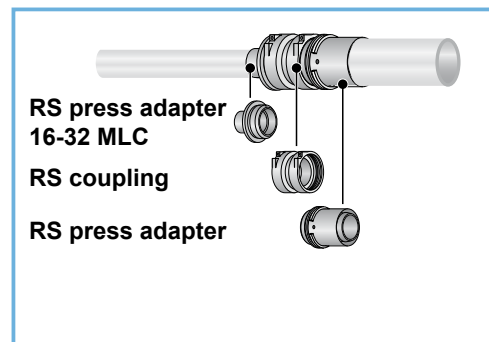

Transitions as required

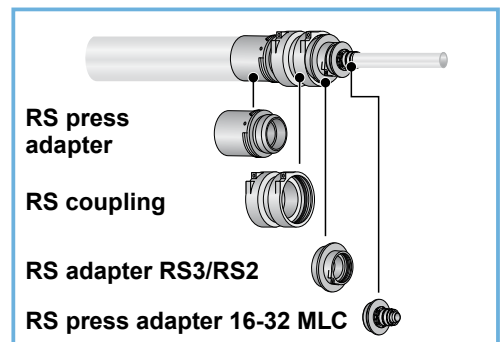

Multi-function spacer

Spacers in the MLC riser fitting system for manifolds and risers fulfil three on-site requirements at once:

- They make it easier to install manifolds on different levels
- They make it possible to install T-manifolds module by module
- They can be used as anchors.

Anchors for temperature-induced linear expansion

Anchors are often necessary in pipe systems with long distribution sections. They are quick and easy to construct with spacers (RS2/RS3). The ridges around the middle of the spacers make it easier to secure anchor clips.

• The plus points

- Easy and quick to install Ideal for producing main
- Ideal for producing main manifolds for example in advance
- Maximum range of applications with just four types of spacer (RS2 and RS3)
- Particularly suitable for renovations and extensions of older sites.

Easy and quick to switch pipe levels

In a manifold network the main distribution pipes and branch pipes often run at different levels. In combination with 45° elbows the spacers enable jumps between levels with only a minimal difference in height.

The length of the spacers is optimised so as to leave enough space between the installation levels to ensure the pipes can be insulated according to thermal insulation requirements.

Flexible design of main manifolds

One-piece manifolds, e. g. ones made out of welded steel tubes, frequently have to be produced for particular applications, which requires planning the site and time schedule precisely. Often, however, suddenly changing the size on site is no longer an option.

The modular fitting system from Uponor and its spacers allow you to produce flexible manifolds of different sizes in just a few steps. The lengths of the spacers are measured so as to ensure that they easily comply with the requirements for the subsequent thermal insulation of the manifolds or pipes.

Flexible elbows

Walls and ceilings are not always set at right angles to one another, particularly in old buildings. This requires pipe systems which can change direction to adapt to individual buildings. By twisting the components, any elbow required can be created, using the short (5 mm) spacers in combination with two 45° elbows.



Technical data and delivery dimensions

Dimensions OD x s [mm]	12 x 1.6	16 x 2	20 x 2,25	25 x 2,5	32 x 3
Inner diameter ID [mm]	8.8	12	15.5	20	26
Length coil [m]	100	100/200/500	100/200	50/100	50
Length straight length [m]	-	5	5	5	5
Outer diameter coil [cm]	78	80	100	120	120
Weight coil/straight length [g/m]	66/-	105/118	148/160	211/240	323/323
Weight coil/straight length with water 10 °C [g/m]	128/-	218/231	337/349	525/554	854/854
Weight per coil [kg]	6.6	10.5/21.0/52.5	14.8/29.6	10.6/21.1	16.2
Weight per straight length [kg]	-	0.59	0.80	1.20	1.6
Water volume [l/m]	0.062	0.113	0.189	0.314	0.531
Pipe roughness k [mm]	0.0004	0.0004	0.0004	0.0004	0.0004
Thermal conductivity λ (W/m x K)	0.40	0.40	0.40	0.40	0.40
Coefficient of expansion α (m/m x K)	25×10^{-6}	25×10^{-6}	25×10^{-6}	25×10^{-6}	25×10^{-6}

Resistance of temperature:

Tap water: The maximum permanent operating temperature exists between 0°C and 70°C at a maximum permanent operating pressure of 10 bars*. The short-term malfunction temperature is 95°C of a maximum of 100 hours in the operating lifetime.

Heating: The maximum permanent operating temperature is 80°C at a maximum permanent operating pressure of 10 bars*. The short-term malfunction temperature is 95°C of a maximum of 150 hours in the operating time per year.

*In some special products the permanent operating pressure is lower than 10 bars. Please have a look on the pipe marking.

Min. bending radius by hand:					
5 x OD [mm]	60	80	100	125	160
Min. bending radius with inner blending spring 4 x OD [mm]	48	64	80	100	128
Min. bending radius with outer blending spring 4 x OD [mm]	-	64	80	100	-
Min. bending radius with bending tool [mm]	-	46	80	83	111

* Please contact the Uponor if you require additional explanation of the parameters

Dimensions OD x s [mm]	40 x 4	50 x 4.5	63 x 6	75 x 7.5	90 x 8.5	110 x 10
Inner diameter ID [mm]	32	41	51	60	73	90
Length coil [m]	-	-	-	-	-	-
Length straight length [m]	5	5	5	5	5	5
Outer diameter coil [cm]	-	-	-	-	-	-
Weight coil/straight length [g/m]	-/508	-/745	-/1224	-/1788	-/2545	-/3597
Weight coil/straight length with water 10 °C [g/m]	-/1310	-/2065	-/3267	-/4615	-/6730	-/9959
Weight per coil [kg]	-	-	-	-	-	-
Weight per straight length [kg]	2.54	3.73	6.12	8.94	12.73	17.99
Water volume [l/m]	0.800	1.320	2.040	2.827	4.185	6.362
Pipe roughness k [mm]	0.0004	0.0004	0.0004	0.0004	0.0004	0.0004
Thermal conductivity λ (W/m x K)	0.40	0.40	0.40	0.40	0.40	0.40
Coefficient of expansion α (m/m x K)	25 x 10 ⁻⁶	25 x 10 ⁻⁶	25 x 10 ⁻⁶	25 x 10 ⁻⁶	25 x 10 ⁻⁶	25 x 10 ⁻⁶

Resistance of temperature:

Tap water: The maximum permanent operating temperature exists between 0°C and 70°C at a maximum permanent operating pressure of 10 bars*. The short-term malfunction temperature is 95°C of a maximum of 100 hours in the operating lifetime.

Heating: The maximum permanent operating temperature is 80°C at a maximum permanent operating pressure of 10 bars*. The short-term malfunction temperature is 95°C of a maximum of 150 hours in the operating time per year.

*In some special products the permanent operating pressure is lower than 10 bars. Please have a look on the pipe marking.

Min. bending radius by hand:

5 x OD [mm]	-	-	-	-	-	-
Min. bending radius with inner blending spring 4 x OD [mm]	-	-	-	-	-	-
Min. bending radius with outer blending spring 4 x OD [mm]	-	-	-	-	-	-
Min. bending radius with bending tool [mm]	160	200	252	-	-	-

* Please contact the Uponor if you require additional explanation of the parameters

Comparison of inner and outer diameters (OD & ID) of Uponor MLC and metal pipes







Copper to BS EN 1057 R250			Uponor MLC			Steel (medium grade) to BS 1387 & ISO 65			
OD	wall thickness	ID	OD	wall thickness	ID	OD	wall thickness	ID	Nom. Size
10	0.6	8.8	12	1.6	8.8				
12	0.6	10.8	16	2	12				
15	0.7	13.6	20	2.25	15.5	21.3	2.6	16.1	15 (1/2")
22	0.9	20.2	25	2.5	20	26.9	2.6	21.7	20 (3/4")
28	0.9	26.2	32	3	26	33.7	3.2	27.3	25 (1")
35	1.2	32.6	40	4	32	42.4	3.2	36	32 (1 1/4")
42	1.2	39.6	50	4.5	41	48.3	3.2	41.9	40 (1 1/2")
54	1.2	51.6	63	6	51	60.3	3.6	53.1	50 (2")
66.7	1.2	64.3	75	7.5	60	76.1	3.6	68.9	65 (2 1/2")
76.1	1.5	73.1	90	8.5	73	88.9	4	80.9	80 (3")
108	1.5	105	110	10	90	114.9	4.5	105.9	100 (4")

Note: All dimensions are in millimetres [mm]

For equivalent internal diameters Uponor MLC performs better than metal pipes due to the smooth inner pipe surface (pipe coefficient of friction = 0.0004mm). Often a 16mm MLC pipe will be sufficient where a 15mm copper or 15mm steel pipe would normally be used, however, MLC pipe size should be checked by using flow rate and pressure loss tables.

Zeta values and equivalent pipe lengths

A water velocity of 2 m/s has been used for the calculation of equivalent pipe lengths:

Dimensions OD x s [mm] Inner diameter ID [mm]	12 x 1.6 8.8	16 x 2 12	20 x 2.25 15.5	25 x 2.5 20	32 x 3 26	40 x 4 32	50 x 4.5 41	63 x 6 51	75 x 7.5 60	90 x 8.5 73	110 x 10 90
Zeta values ζ (-)/equivalent Pipe length eL [m]	ζ eL	ζ eL	ζ eL	ζ eL	ζ eL	ζ eL	ζ eL	ζ eL	ζ eL	ζ eL	ζ eL
Press elbow 90° 	8.0 2.9	4.4 2.0	3.0 1.9	2.8 2.4	2.3 2.7	2.0 3.1	1.6 3.3	1.4 3.8	1.4 4.6	3.7 15.4	2.9 15.5
Press elbow 45° 	- -	- -	- -	1.5 1.3	1.2 1.4	1.2 1.8	0.8 1.7	0.8 2.2	0.8 2.6	0.7 2.9	0.6 3.2
Reducing 	3.2 1.1	1.7 0.8	1.2 0.8	1.0 0.9	0.9 1.1	0.8 1.2	0.6 1.2	0.6 1.6	0.5 1.6	0.5 2.1	0.7 3.7
Branch at flow split 	9.5 3.4	5.2 2.4	3.6 2.3	3.2 2.7	2.6 3.1	2.4 3.7	1.9 3.9	1.7 4.6	1.7 5.6	3.7 15.4	2.9 15.5
Branch run at flow split 	2.3 0.8	1.2 0.6	0.8 0.5	0.8 0.7	0.7 0.8	0.5 0.8	0.4 0.8	0.4 1.1	0.4 1.3	0.5 2.1	0.4 2.1
Branch reverse run at flow split 	8.4 3.1	4.6 2.1	3.2 2.0	2.9 2.5	2.3 2.7	2.1 3.2	1.7 3.5	1.5 4.1	1.5 4.9	2.2 9.1	1.7 9.1

Tap Water Design

The Uponor MLC system used in tap water installations

Extensive product range for complete installations

Everything that's required from one system: The Uponor MLC tap water program permits complete tap water installations – from the service connection to the final usage point. You select the installation variation, it's your decision: Single connections via a manifold, T-piece or a loop system.

The comfortable system technology ensures a simple and extremely fast installation. And you only use certified and tested quality. Longevity and security have been confirmed by numerous tests. The Uponor MLC system has WRAS, DVGW and SKZ approval and is applicable for tap water installations of all sizes.

With our large selection of special solutions we cover all individual requirements in existing as well as new construction. An extensive assortment of couplings permits the connection of the system to all types of fittings.

The Uponor MLC pipe is certified on the basis of the DVGW W 542 worksheet. This certification takes into consideration the examination and evaluation of micro-organism growth on basis of the DVGW W 270 worksheet as well as numerous mechanical performance requirements. This also includes regular testing of the hygiene requirements in accordance with KTW recommendations (Plastic for tap water recommendations of the "Tap water interests" working group of the plastics commission of the German Federal Health Office). The press and clamp connectors used in the Uponor MLC system are fully tin plated. The brass materials used fulfils all requirements of the new German tap water directive. In accordance with DIN 50930-6 they can be used without restriction with all water qualities that correspond to the German tap water directive.

The system has undergone extensive testing in the UK to gain full Water Regulations Advisory Scheme (WRAS) approval.



Features and Benefits

- Complies with the strict guidelines of the German tap water directive and has full WRAS approval
- 5 layer composite pipe made from foodstuff safe polyethylene
- Manufactured under comprehensive quality control for the safety of the tap water installation
- High quality surface finish inhibits deposits
- Simple and secure mounting
- Practice oriented product range
- Ideally suited for both surface mounted and concealed installation

Protection of tap water

Measures for inhibiting the growth of legionella

Conditions must be established that inhibit an unhealthy concentration of legionella in hot water tanks and their attached warm water distribution systems.

Legionella is rod-shaped bacteria, which naturally occur at low concentrations in fresh water e.g. lakes, rivers and occasionally also in tap water. Approximately 40 forms of the legionella bacteria are known. Some legionella forms can cause infections through the inhalation of contaminated aerosols (fine water droplets) e.g. while showering or through humidifiers in air-conditioners. For people with health problems e.g. weakened immune system, chronic bronchitis etc. this can lead to pneumonia (legionella pneumonia or legionnaire's disease) or to Pontiac fever.

The infection risk is a direct function of the temperature of the water from the tap water installation. The temperature range in which increased legionella growth appears is between 30°C and 45°C.

In order to reduce the risk of legionella growth, cold water in pipes and cisterns should not exceed a temperature of 20°C, while hot water should be stored at a temperature between 60°C and 65°C.

Connection to instantaneous water heaters, hot water tanks and mixer

Connection to a instantaneous water heater

Due to their construction, hydraulically controlled, electrical and gas fired flow heaters can build up high temperatures and pressures, both in normal operation and as a result of a failure, which can cause damage to the pipe system. The Uponor MLC system may only be directly connected to electronically controlled equipment. The manufacturer's instructions must be observed when using electronically controlled equipment to heat tap water.

which is to be checked at start-up or be obtained from the manufacturer. In the case of doubt, suitable safety precautions are to be taken (e.g. installation of an industrial water mixing valve)

Mixer connections

Fitting connection installation must be torsion-proof (e.g. by fixing the press tap elbow on mounting brackets or mounting plates).

Connection to a hot water tank

Generally it must be ensured when connecting hot water tanks (particularly with direct fired hot water tanks, solar storage tanks and special constructions) that in normal operation as well as in the case of a failure, the operation limits of the Uponor MLC pipe are not exceeded. This applies in particular to the maximum warm water outlet temperature,

Planning basis for tap water installation using the Uponor MLC system

Fields of application

The Uponor MLC system is applicable for all sanitary facilities, e.g. for house construction and for public and commercial buildings.

The large selection of Uponor MLC pipes and fittings in the dimensions 12 to 110 mm permits safe and fast tap water installation from a one-family house up to special usage buildings.

The Uponor MLC system offers a large selection of special solutions, whereby all individual requirements in existing as well as new construction can be covered. All currently available sanitary equipment and fittings can be connected to the system.

Certificates

According to DVGW worksheet W 542 a minimum useful life of 50 years must be proven for multi-layer composite pipes used in tap water distribution systems. For this purpose an independent testing institute runs a series of tests in order to produce an internal pressure creep rupture diagram. For Uponor this report was produced by the South German Plastics Centre in Würzburg (SKZ). Along with other tests, the internal pressure creep rupture diagram forms the basis for DVGW issuing a mark of approval for Uponor with all associated connectors. Together with the test institute and DVGW, Uponor works continuously on the testing of the pipe system in accordance with all relevant DVGW worksheets.

Classification, Approvals and Affiliations

All Uponor pipes are manufactured in accordance with the international quality standard of ISO9001 and to the environmental standard of ISO14001.

Uponor products have been independently assessed and meet the requirements of the UK Water Regulations.

Wras approval numbers:

RTM; 1002036

Riser; 1102044

Press fittings; 1111077



DVGW certification permits the use of the Uponor MLC systems in tap water installations in accordance with the requirements of DIN 1988 TRWI (Technical regulations for drinking-water installations) All components coming into contact with tap water are materials and articles accepted by the German Foodstuff and Consumer Goods Act. The Uponor MLC system corresponds to the recommendations of the German Federal Board of Health (KTW recommendation), and through the DVGW mark of approval is also accordingly reviewed and recognized.

The brass alloy used for the Uponor MLC fittings corresponds to DIN 50930-6 and fulfils the requirements of the German tap water directive (TrinkwV).

For use world-wide, Uponor has more than 60 international certificates, including WRAS approval for the United Kingdom.



Uponor is affiliated with the following organisations:

CIPHE: Chartered Institute of Plumbing and Heating Engineering



BSRIA: Building Services Research and Information Association



BPF: British Plastics Federation – Plastic Pipes Group



SNIPF: Scottish & Northern Ireland Plumbers Federation



RIBA CPD: Royal Institute of British Architects Network Provider



BEAMA:



MLC Smart End Elbow Range

For Uponor Tap Water System



Your benefits:

- Easier handling
- Greater flexibility
- Better fixation
- Optimized portfolio

One hand installation

The NEW fixation design allows fixation of the new Smart End Elbows onto the new mounting plates, angles and tracks much easier using just “one hand.” Try it!

Seal cover on the screw tip will hold the screw in place. Preventing it from slipping out during the Smart End Elbow installation process.

More mounting possibilities

Use the NEW design Smart End Elbows for both: on wall direct mounting or mounting onto the new mounting plates, angles and tracks.

Easier positioning

The new guiding pins allow for simple quick positioning. Choose an installation angle and put the Smart End Elbow onto a mounting plate, angle or track.

Less items

Smart End Elbow Range is created to use less items and cover more installation options.

Wholesalers:

- Less items in portfolio
- Less lead time

Installers:

- Less stock in the van
- Less items to carry

Again less is more

- Compatible with all new mounting plates, angles and tracks
- Sound insulation
- Longer pins and screws

New design U-profile tap elbow

New U-profile tap elbow perfectly fits into hygiene oriented and water flow rate optimized installations using different loop installation methods.

- Use the same Smart End Elbow fixation solution
- Improved profile design allowing better flow rate
- Simpler and more flexible installation

Installation variations

T-fitting installation

The T-fitting installation is still the most commonly deployed installation method. The setup usually starts with a larger dimension that is reduced gradually up to the last tap. Although piping efforts are minor, it is necessary to install a single pipe from the T-fitting to the tap.

The installation variant with T-fittings should only be used for taps that are in use on a daily or regular basis; however,

a minimum risk to hygiene cannot be safely excluded due to stagnating water.

Pressure losses in the installation system can be minimized by initially larger pipe dimensions. Consumers can benefit from a high level of comfort at the tap even at low operational pressure.

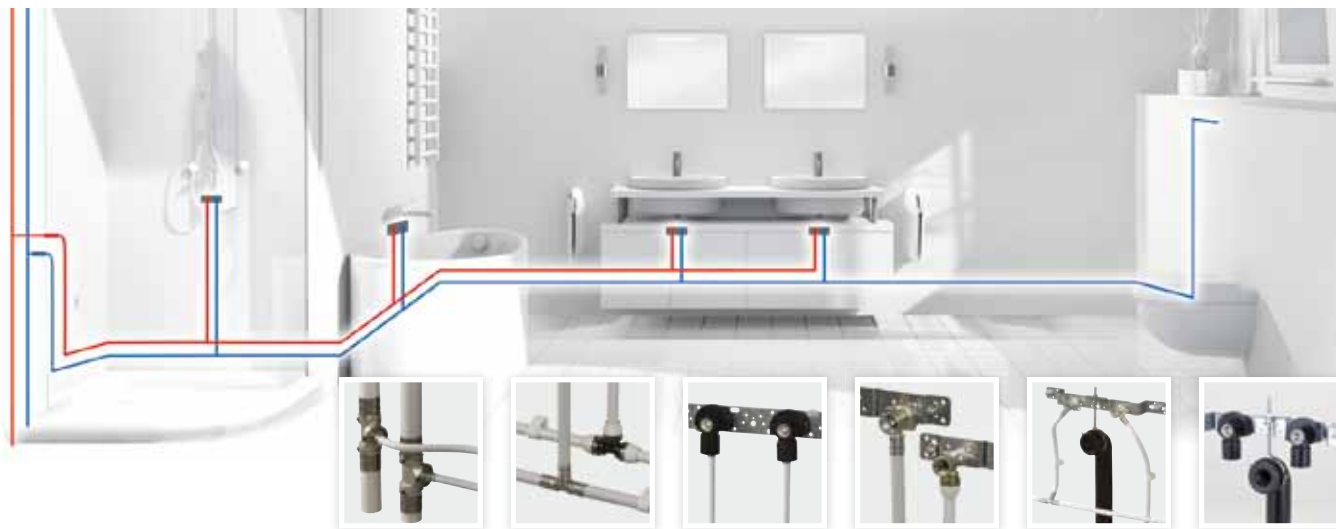

Serial installation

The serial installation prevents the collection of stagnation water in the feed lines of consumers that are rarely in use, e.g. outdoor taps in a single-family home, or a washing machine connection in the shared laundry of a multi-family property.

In this system, the consumers are connected by means of Uponor U-end elbows that are routed directly to the next consumer, therefore excluding any stagnation of the water in the system if the plan is to install the consumer that is used most frequently, usually the toilet flushing or basin at the end

of the serial installation. This means that the last consumer propagates the exchange of water at the upstream piping and taps.

The Uponor prefab press tap elbows and mounting panels, rails and sets support the flexible and rapid serial installation, while reducing piping material and making it relatively simple to route the piping. The pressure loss is lower when consumers that demand the highest total flow rate are positioned at the start and not at the end of the piping segment.



Loop installation

The Uponor U-end elbows are also used to connect the taps to the loop installation and to route the multi layer composite pipes directly to the next tap. However, the piping is routed back from the last object to the riser pipe. The ring installation system is therefore hygienically impeccable, thanks to the optimized turnover of water in the piping. In order to achieve a consistent hygienic flow in the loop installation, it is advisable to select a pipe with the same diameter as far as possible and less than that of the serial installation, as the objects are supplied from both sides.

Compared to the serial installation, the lower pressure losses allows you to significantly increase the number of tap outlets per installation system. However, as this renders the planning and calculation processes slightly more complex, you may rely on the building technology software Uponor HSE that provides you with support when engineering the project.

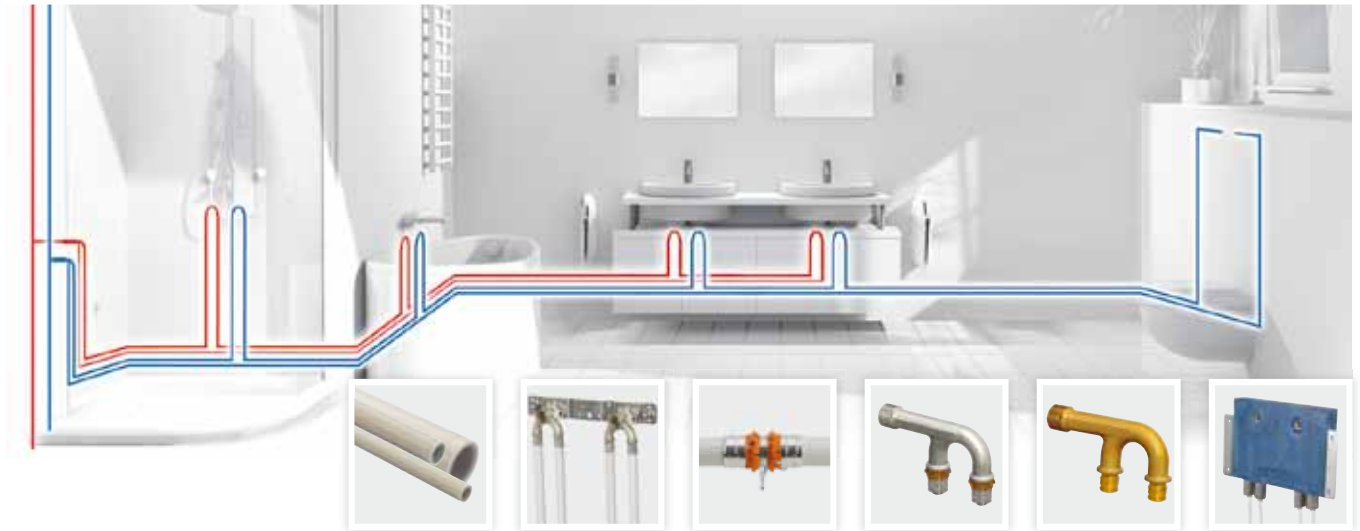

Heating

Radiator connection with the Uponor MLC system

One system for all radiators

The Uponor MLC radiator connection system allows you to install complete heating systems – from the heat generator to the furthest radiator – fast and economically. The program can be combined without problems with all boilers and radiators offered on the market.

Convince yourself of the variety of the Uponor MLC system with its components for house or story orientated distribution, control and temperature measurement. Extensive accessories round off the assortment.

Use of trace heating

The Uponor MLC pipe is suitable for use with trace heating. The inner aluminium pipe ensures uniform heat distribution around the pipe, the customary temperature limitation of 60°C by the manufacturer is to be respected.

The fixing of the heating band is to be done according to the manufacturer's instructions, whereby the Uponor MLC pipe is to be classified as a plastic pipe.

You must make sure that the water can expand correspondingly if Uponor MLC pipes with a self-regulating heating band are permitted. If this is not the case, damage of the Uponor pipe due to the high increase in pressure cannot be ruled out. For these cases suitable safeguards are to be taken, e.g. the installation of a suitable safety valve or expansion vessel.

Variety of connections

The system for connecting radiators is a complete system containing many components. This opens up various connection possibilities. They are suitable for single or double pipe connections and can be quickly and securely connected to all common radiators, whether directly out of the floor or wall. The benefit of flexibility: You can use any pipe installation method.



Note:

The pressure increase of the components due to the use of heating tape is to be closely watched. Suitable safety precautions are to be planned that ensure pressure equalization. The manufacturer's assembly guidelines and installation notes for the self-regulating heating band must be observed.



Connection variations with MLC system

Chromed Press Connection Elbow

The Uponor chromed press connection elbow is used with 12mm MLC pipes. It has a press connection for 12mm MLC and 15mm plated copper tail for connection to a standard compression bodied radiator valve. This elbow fitting is often used where radiator flow and return pipes are routed in the cavity behind dot and dab walls.

Product Code: 1014644



Chromed Radiator Compression Elbow

This compression elbow is used for connecting either 12mm MLC or 16mm MLC pipes onto standard compression type radiator valves. An MLC compression adaptor is required to connect the elbow fitting to the MLC pipe and has 15mm plated copper tail for connection to the radiator valve.

Product Code: 1002124

12mm MLC compression adaptor, Product Code: 1013813

16mm MLC compression adaptor, Product Code: 1013806



Press Connection Tee

The Uponor press connection tee is a press fitting designed for 16mm MLC pipes. It incorporates a bent 15mm centre connection of plated copper pipe, which is available in tail lengths of 350mm. This is a robust connection to radiator valves when flow and return pipes are routed from beneath the floor level.

Press connection tee (350mm), Product Code: 1015628

Press connection elbow (350mm), Product Code: 1015626

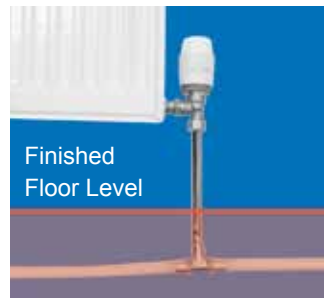

Radiator Connection Guide

The radiator connection guide provides additional protection for 12mm MLC pipe. It is available for solid floor installation as shown in the photo above. In this instance, 12mm MLC pipe is run inside a corrugated pipe that is embedded within the floor screed. Radiator connection guides are also available for joist floor construction.

Pack of 2 radiator connection guides (solid floor), Product Code: 1002237

Pack of 2 radiator connection guides (joisted floor), Product Code: 1002238

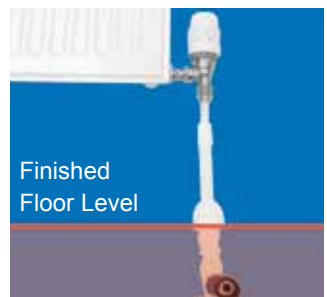

Features and Benefits

- Practical radiator connection variations for new construction as well as renovation
- Absolutely oxygen diffusion tight multi-layer composite pipe
- Pre-insulated multi-layer composite pipes and components
- Extensive assortment of fittings
- Extensive accessory program

Planning basis for radiator connection

Primary Connections

The illustration below shows a two dimensional plumbing schematic of a manifold fed radiator and UFH system. Both systems are supplied by the same system boiler and a hot water cylinder is also shown.

Each circuit is isolated via a zone valve. If one of the radiator thermostats calls for heat the thermostat's corresponding thermal actuator will open. The Controller C-55 will then send a demand signal to the radiator circuit zone valve which once fully open will send a demand to fire the boiler.

The UFH will work in a similar way to the radiator system. The hot water cylinder will be supplied by the boiler if the cylinder thermostat calls for heat. This will open the cylinder zone valve which, once open, will again send a signal to fire the boiler. This circuit would not be required if a combi-boiler was installed.

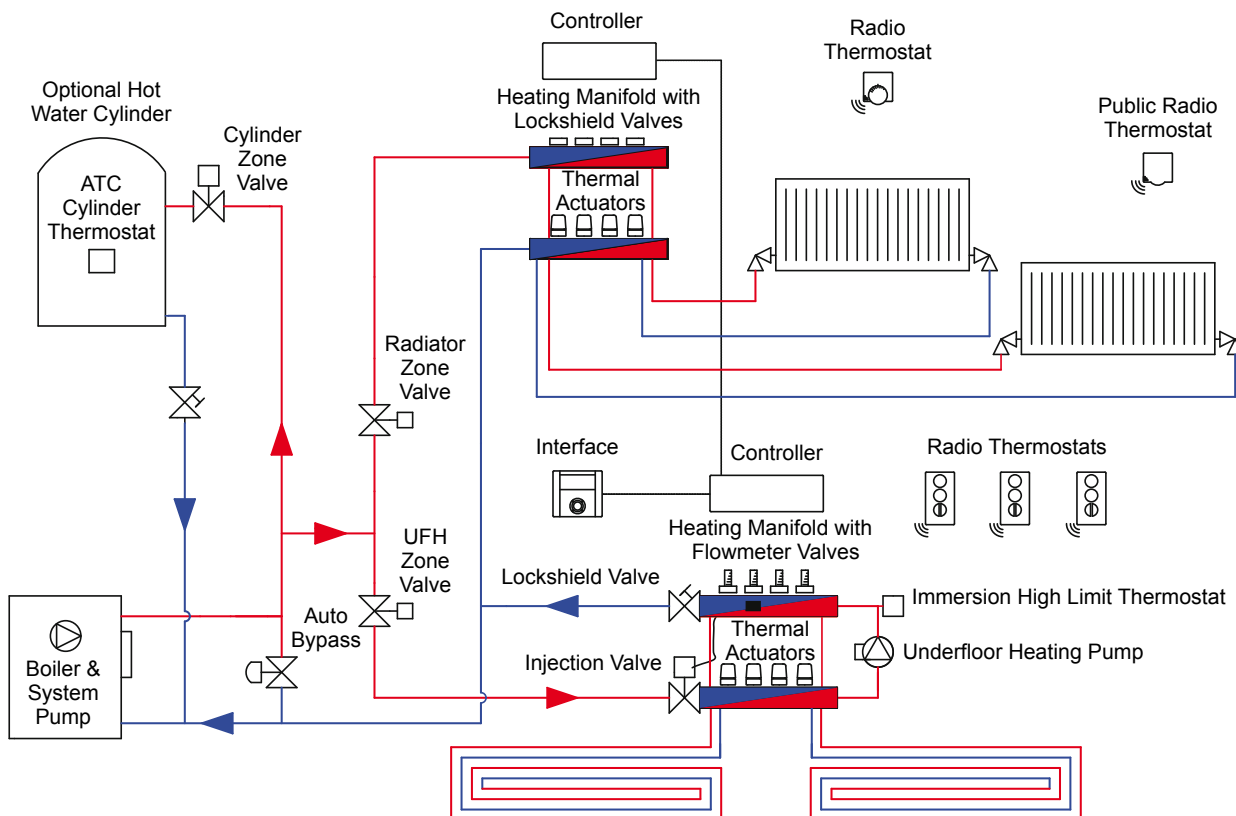

Fields of application

All heating system components can be connected using the high-quality Uponor MLC pipes with an outside diameter of 12 - 32mm in coils and 16-110mm in straight lengths together with suitable system components such as press and screw fittings. The possibility of supplying over-sized pipe dimensions of up to OD = 110mm permits their use as main distribution lines in larger heating systems.

The high resilience of Uponor MLC makes it especially suitable for heating installations:

- Maximum temperature: 95°C*
- Maximum continuous operating pressure: 10 bar at a continuous operation temperature of 80°C for heating, tested hydrostatic stress performance of 50 years, safety factor 1.5*

* Please contact the manufacturer if you require additional explanation of the installation parameters.



Caution: Uponor MLC pipes may not be directly connected to systems with operating temperatures $\geq 95^{\circ}\text{C}$, such as solar or district heating systems. It must be ensured that the operational limits of the Uponor pipe are not exceeded under any conditions.

With the following methods you can realise trouble-free heating water distribution using the Uponor MLC system:

- Single-pipe heating system
- Double-pipe heating system
- Reverse Return system

Installation possibilities

The double-pipe heating system with its variations for the single and multi-family dwelling sectors is particularly suitable for low-temperature heaters. With this installation variation the radiators are connected to the supply and return.

All radiators have approximately the same supply temperature. A benefit is the fast and easy adjustment of the double-pipe heating system.

Double-pipe heating system with manifold

With this installation variation the heating water distribution is connected to the radiators by means of single inlets from a central manifold. The Uponor manifold is in turn connected to the main heating flow and return lines from the heat generator.

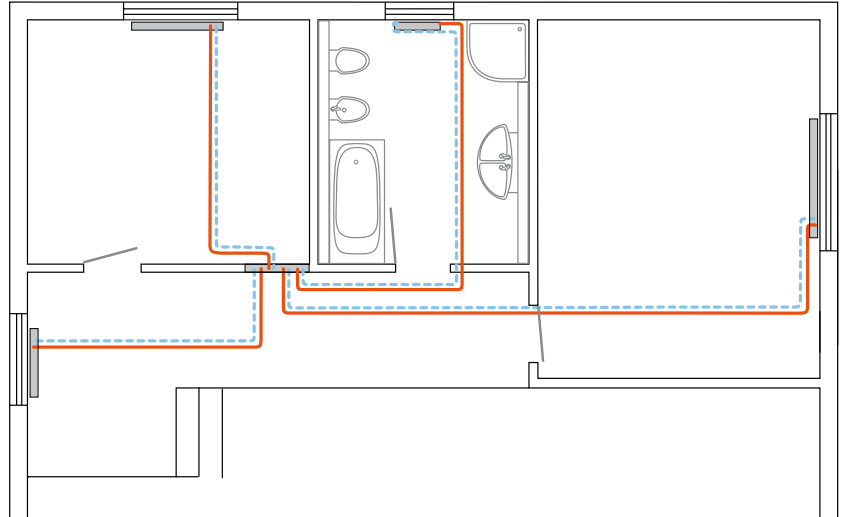

Double-pipe heating system with branch connections

Starting from the main heating flow and returns, the heating water distribution is made by a common ring loop. If the ring loop runs directly by the radiator, the radiator connection can be made with a press connection tee.

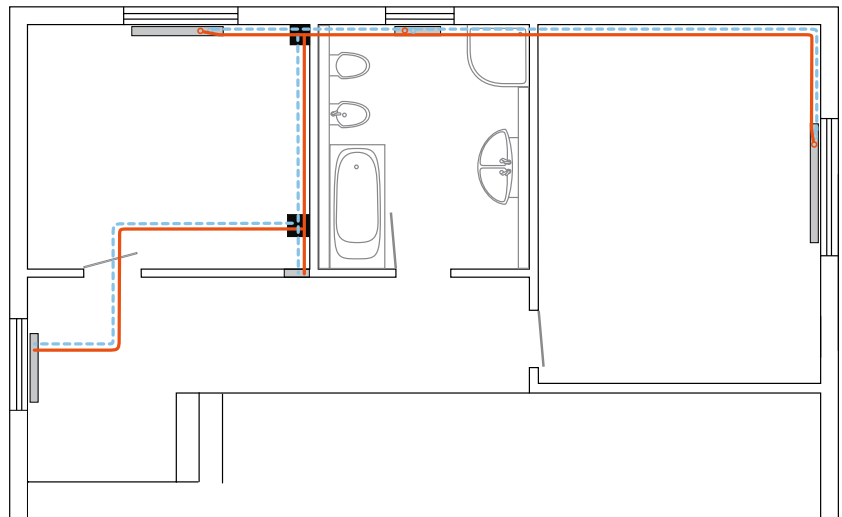

Reverse Return system

In the Reverse Return system the pipes are arranged in such a way that the sum of the length of supply and return for each radiator is approximately equal. That means that the radiator with the longest supply has the shortest return. Thus a more uniform pressure drop in the individual sections of pipe is achieved.

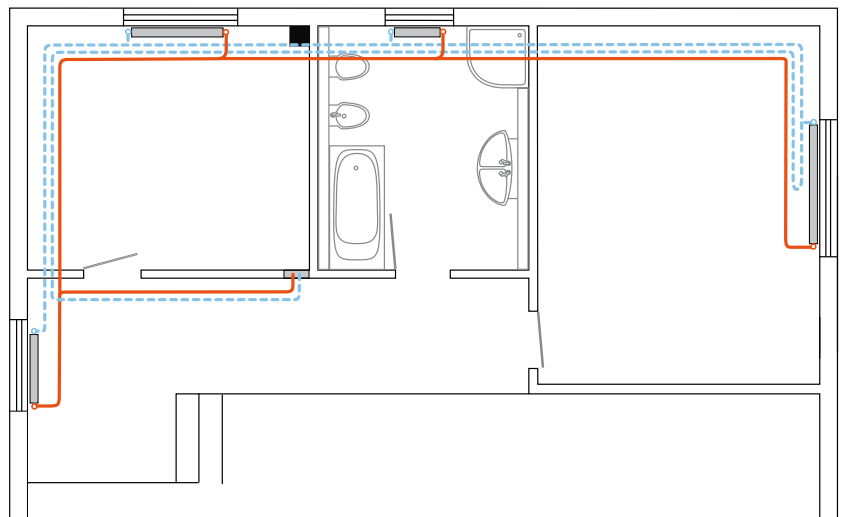

Radiator Manifolds

Vario B Manifold

Uponor uses the Vario B manifold as the standard distributor for radiator systems. This manifold is available in 2 to 8 port sizes and incorporates manual air vents on both the flow and return manifold headers. A single port extension set is also available.

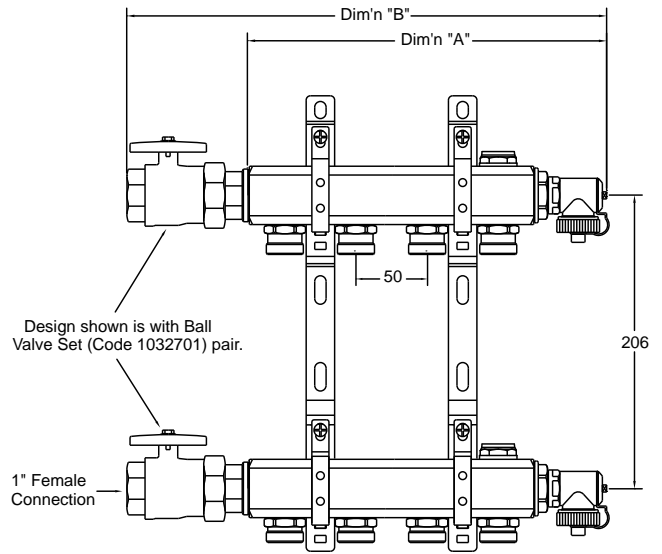

Vario B with valve Manifold

The Vario B with valve, manifold range allows for sophisticated controls to be incorporated into a traditional radiator heating system. The Vario B with valve, manifold can be fitted with 24V electro-thermal actuators, which will open/close individual ports when switched by the corresponding room thermostat. The new Uponor Control System – Radio can be used as an alternative to a more conventional hard wired control system; the same advanced controls are used in our underfloor heating (UFH) systems.

Vario B with valve, manifolds are available in 2 to 12 port sizes. A single port extension set is also available. Each manifold port is rated for a maximum flow rate of 6 l/m (= 0.01 kg/s), which equates to 4.5 kW radiator output when based on the standard 11°C difference between flow and return water temperatures (Δt). A Δt of 20°C will increase maximum radiator output per port to around 8 kW. Each individual flow port incorporates a lockshield valve for simple centralised hydraulic balancing of the radiator circuits.

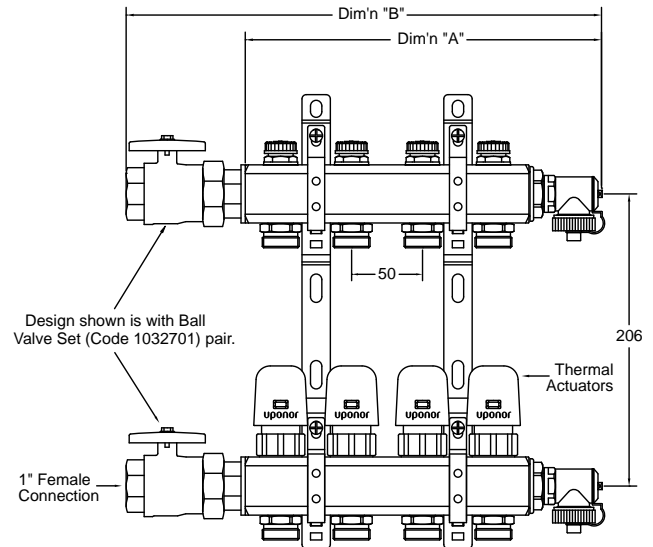

No. Ports	Dim'n "A"	Dim'n "B" with 1" F.T. Ball Valve Set
2	151	251
3	201	301
4	251	351
5	301	401
6	351	451
7	401	501
8	451	551

Extended range for LS manifold

9	501	601
10	551	651
11	601	701
12	651	751

Calculation example

The selection of the respective pipe dimension depends on the required mass flow rate (volume flow) of the particular section of pipe. Depending upon the dimension of the pipe's OD x s, the water velocity v and the pipe friction resistance R change.

If the pipe selected is too small, the water velocity v and the pipe friction resistance R rise. This leads to higher flow noises and to higher current usage of the circulation pump.

During the design of the pipeline we recommend that you not to exceed the following approximate velocity values:

Radiator connection pipe: ≤ 0.3 m/s

Radiator distribution pipe: ≤ 0.5 m/s

Heating main pipes: ≤ 1.0 m/s

The pipe network has to be planned in such a way that the flow rate decreases uniformly from the boiler to the furthest radiator. The guidelines for the water velocity are to be observed.

The maximum transferable thermal output Q_N is to be entered in the following tables under consideration of the maximum water velocity, in relationship to the type of pipe, spread ΔT and the pipe dimension OD x s.

Radiator connection pipe: ≤ 0,3 m/s

Pipe OD x s [mm]	12 x 1.6	16 x 2	20 x 2.25	25 x 2.5	32 x 3
Mass flow rate \dot{m} (kg/h)	64	122	204	339	573
Thermal output Q _N (W) at Δ T = 5 K	375	710	1185	1972	3333
Thermal output Q _N (W) at Δ T = 10 K	749	1420	2369	3944	6666
Thermal output Q _N (W) at Δ T = 15 K	1124	2130	3554	5916	9999
Thermal output Q _N (W) at Δ T = 20 K	1499	2840	4738	7889	13332
Thermal output Q _N (W) at Δ T = 25 K	1874	3550	5923	9861	16665

Radiator distribution pipe: ≤ 0,5 m/s

Pipe OD x s [mm]	12 x 1.6	16 x 2	20 x 2.25	25 x 2.5	32 x 3	40 x 4
Mass flow rate \dot{m} (kg/h)	108	204	340	565	956	1448
Thermal output Q _N (W) at Δ T = 5 K	628	1183	1974	3287	5555	8414
Thermal output Q _N (W) at Δ T = 10 K	1256	2367	3948	6574	11110	16829
Thermal output Q _N (W) at Δ T = 15 K	1884	3550	5923	9861	16665	25243
Thermal output Q _N (W) at Δ T = 20 K	2512	4733	7897	13148	22219	33658
Thermal output Q _N (W) at Δ T = 25 K	3140	5916	9871	16434	27774	42072

Heating main pipes: ≤ 1,0 m/s

Pipe OD x s [mm]	12 x 1.6	16 x 2	20 x 2.25	25 x 2.5	32 x 3	40 x 4
Mass flow rate \dot{m} (kg/h)	216	407	679	1131	1911	2895
Thermal output Q _N (W) at Δ T = 5 K	1256	2367	3948	6574	11110	16829
Thermal output Q _N (W) at Δ T = 10 K	2512	4733	7897	13148	22219	33658
Thermal output Q _N (W) at Δ T = 15 K	3768	7100	11845	19721	33329	50487
Thermal output Q _N (W) at Δ T = 20 K	5024	9466	15794	26295	44439	67316
Thermal output Q _N (W) at Δ T = 25 K	6280	11833	19742	32869	55548	84144

Example:

Calculating the mass flow rate \dot{m} (kg/h)

$$\dot{m} = Q_N / (c_W \times (t_{VL} - t_{RL}))$$

$$\dot{m} = 1977 \text{ W} / (1.163 \text{ Wh}/(\text{kg K}) \times (70^\circ\text{C} - 50^\circ\text{C}))$$

$$\dot{m} = 85 \text{ kg/h m}$$

where:

- c_W specific thermal capacity
Hot water ≈ 1,163 Wh/(kg x K)
- t_{VL} supply temperature in °C
- t_{RL} return temperature in °C
- Q_N rated output in W

The specific thermal capacity of the hot water is calculated with a c_W ≈ 1,163 Wh/(kg x K).

Note: With single pipe heating systems the total ring volume flow of all radiators has to be observed.

Calculation basis for tap water connection

Cold water pipe sizing table

Flow of water at 10 deg C

Δp_l	v	12 mm		14 mm		16 mm		20 mm		25 mm		32 mm		v	Δp_l
		M	l_e	M	l_e	M	l_e	M	l_e	M	l_e	M	l_e		
0.1								0.001	0.1	0.001	0.1	0.003	0.2		0.1
0.2						0.0004	0.0	0.001	0.1	0.002	0.1	0.005	0.2		0.2
0.3						0.0006	0.0	0.001	0.1	0.003	0.1	0.006	0.2		0.3
0.4				0.0004	0.0	0.0007	0.1	0.002	0.1	0.003	0.2	0.008	0.3		0.4
0.5				0.0005	0.0	0.0009	0.1	0.002	0.1	0.004	0.2	0.009	0.3		0.5
0.6				0.0006	0.0	0.0010	0.1	0.002	0.1	0.005	0.2	0.010	0.3		0.6
0.7		0.0004	0.0	0.0006	0.0	0.0011	0.1	0.002	0.1	0.005	0.2	0.011	0.3		0.7
0.8		0.0005	0.0	0.0007	0.0	0.0012	0.1	0.003	0.1	0.005	0.2	0.012	0.3		0.8
0.9		0.0005	0.0	0.0007	0.0	0.0013	0.1	0.003	0.1	0.006	0.2	0.013	0.3		0.9
1.0		0.0005	0.0	0.0008	0.1	0.0014	0.1	0.003	0.1	0.006	0.2	0.013	0.3		1.0
1.5		0.0007	0.0	0.0011	0.1	0.0018	0.1	0.004	0.1	0.008	0.2	0.017	0.4		1.5
2.0		0.0009	0.1	0.0013	0.1	0.0022	0.1	0.005	0.2	0.010	0.2	0.021	0.4		2.0
2.5		0.0010	0.1	0.0015	0.1	0.0025	0.1	0.005	0.2	0.011	0.3	0.024	0.4		2.5
3.0		0.0011	0.1	0.0017	0.1	0.0029	0.1	0.006	0.2	0.013	0.3	0.026	0.4	0.05	3.0
3.5		0.0013	0.1	0.0018	0.1	0.0032	0.1	0.007	0.2	0.014	0.3	0.029	0.4		3.5
4.0		0.0014	0.1	0.0020	0.1	0.0034	0.1	0.007	0.2	0.015	0.3	0.032	0.4		4.0
4.5		0.0015	0.1	0.0022	0.1	0.0037	0.1	0.008	0.2	0.016	0.3	0.034	0.5		4.5
5.0		0.0016	0.1	0.0023	0.1	0.0040	0.1	0.008	0.2	0.017	0.3	0.036	0.5		5.0
5.5		0.0017	0.1	0.0025	0.1	0.0042	0.1	0.009	0.2	0.018	0.3	0.038	0.5		5.5
6.0		0.0018	0.1	0.0026	0.1	0.0045	0.1	0.009	0.2	0.019	0.3	0.040	0.5		6.0
6.5		0.0019	0.1	0.0028	0.1	0.0047	0.1	0.010	0.2	0.020	0.3	0.042	0.5		6.5
7.0		0.0020	0.1	0.0029	0.1	0.0049	0.1	0.010	0.2	0.021	0.3	0.044	0.5		7.0
7.5		0.0021	0.1	0.0030	0.1	0.0051	0.1	0.011	0.2	0.022	0.3	0.046	0.5		7.5
8.0		0.0022	0.1	0.0032	0.1	0.0053	0.1	0.011	0.2	0.023	0.3	0.048	0.5		8.0
8.5		0.0023	0.1	0.0033	0.1	0.0055	0.1	0.012	0.2	0.024	0.3	0.050	0.5		8.5
9.0		0.0023	0.1	0.0034	0.1	0.0058	0.1	0.012	0.2	0.025	0.3	0.051	0.5		9.0
9.5		0.0024	0.1	0.0035	0.1	0.0059	0.1	0.012	0.2	0.025	0.3	0.053	0.5		9.5
10.0		0.0025	0.1	0.0036	0.1	0.0061	0.1	0.013	0.2	0.026	0.3	0.055	0.5		10.0
12.5	0.05	0.0029	0.1	0.0042	0.1	0.0071	0.2	0.015	0.2	0.030	0.4	0.062	0.6		12.5
15.0		0.0032	0.1	0.0047	0.1	0.0079	0.2	0.016	0.2	0.033	0.4	0.070	0.6		15.0
17.5		0.0036	0.1	0.0052	0.1	0.0087	0.2	0.018	0.3	0.037	0.4	0.076	0.6	0.15	17.5
20.0		0.0039	0.1	0.0056	0.1	0.0094	0.2	0.019	0.3	0.040	0.4	0.082	0.6		20.0
22.5		0.0042	0.1	0.0060	0.1	0.0101	0.2	0.021	0.3	0.043	0.4	0.088	0.6		22.5
25.0		0.0045	0.1	0.0064	0.1	0.0108	0.2	0.022	0.3	0.045	0.4	0.094	0.6		25.0
27.5		0.0047	0.1	0.0068	0.1	0.0115	0.2	0.024	0.3	0.048	0.4	0.099	0.6		27.5
30.0		0.0050	0.1	0.0072	0.1	0.0121	0.2	0.025	0.3	0.051	0.4	0.105	0.6		30.0
32.5		0.0053	0.1	0.0076	0.1	0.0127	0.2	0.026	0.3	0.053	0.4	0.110	0.7		32.5
35.0		0.0055	0.1	0.0079	0.1	0.0133	0.2	0.027	0.3	0.055	0.4	0.115	0.7		35.0
37.5		0.0057	0.1	0.0083	0.1	0.0138	0.2	0.028	0.3	0.058	0.5	0.119	0.7		37.5
40.0		0.0060	0.1	0.0086	0.1	0.0144	0.2	0.030	0.3	0.060	0.5	0.124	0.7		40.0
42.5		0.0062	0.1	0.0089	0.2	0.0149	0.2	0.031	0.3	0.062	0.5	0.128	0.7		42.5
45.0		0.0064	0.1	0.0092	0.2	0.0155	0.2	0.032	0.3	0.064	0.5	0.133	0.7		45.0
47.5		0.0066	0.1	0.0095	0.2	0.0160	0.2	0.033	0.3	0.066	0.5	0.137	0.7		47.5
50.0		0.0069	0.1	0.0099	0.2	0.0165	0.2	0.034	0.3	0.068	0.5	0.141	0.7		50.0
52.5		0.0071	0.1	0.0102	0.2	0.0170	0.2	0.035	0.3	0.070	0.5	0.145	0.7		52.5
55.0		0.0073	0.1	0.0104	0.2	0.0174	0.2	0.036	0.3	0.072	0.5	0.149	0.7		55.0
57.5		0.0075	0.1	0.0107	0.2	0.0179	0.2	0.037	0.3	0.074	0.5	0.153	0.7		57.5
60.0		0.0077	0.1	0.0110	0.2	0.0184	0.2	0.038	0.3	0.076	0.5	0.157	0.7	0.3	60.0
62.5		0.0079	0.1	0.0113	0.2	0.0188	0.2	0.038	0.3	0.078	0.5	0.161	0.7		62.5
65.0		0.0081	0.1	0.0116	0.2	0.0193	0.2	0.039	0.3	0.080	0.5	0.164	0.7		65.0
67.5		0.0082	0.1	0.0118	0.2	0.0197	0.2	0.040	0.3	0.082	0.5	0.168	0.7		67.5
70.0		0.0084	0.1	0.0121	0.2	0.0202	0.2	0.041	0.3	0.083	0.5	0.172	0.7		70.0
72.5		0.0086	0.1	0.0123	0.2	0.0206	0.2	0.042	0.3	0.085	0.5	0.175	0.8		72.5
75.0		0.0088	0.1	0.0126	0.2	0.0210	0.2	0.043	0.3	0.087	0.5	0.179	0.8		75.0
77.5	0.15	0.0090	0.1	0.0129	0.2	0.0214	0.2	0.044	0.3	0.089	0.5	0.182	0.8		77.5

M = mass flow rate **kg/s** l_e = equivalent length of pipe **m** Δp_l = pressure loss per unit length **Pa/m** v = velocity **m/s**

Flow of water at 10 deg C

Δp_l	v	12 mm		14 mm		16 mm		20 mm		25 mm		32 mm		v	Δp_l
		M	l_e	M	l_e	M	l_e	M	l_e	M	l_e	M	l_e		
80.0		0.0091	0.1	0.0131	0.2	0.0216	0.2	0.045	0.3	0.090	0.5	0.185	0.8		80.0
82.5		0.0093	0.1	0.0133	0.2	0.0223	0.2	0.045	0.4	0.092	0.5	0.189	0.8		82.5
85.0		0.0095	0.1	0.0136	0.2	0.0227	0.2	0.046	0.4	0.093	0.5	0.192	0.8		85.0
87.5		0.0097	0.1	0.0138	0.2	0.0230	0.2	0.047	0.4	0.095	0.5	0.195	0.8		87.5
90.0		0.0098	0.1	0.0141	0.2	0.0234	0.2	0.048	0.4	0.097	0.5	0.199	0.8		90.0
92.5		0.0100	0.1	0.014	0.2	0.024	0.2	0.049	0.4	0.098	0.5	0.202	0.8		92.5
95.0		0.0101	0.1	0.015	0.2	0.024	0.2	0.049	0.4	0.100	0.5	0.205	0.8		95.0
97.5		0.0103	0.1	0.015	0.2	0.025	0.2	0.050	0.4	0.101	0.5	0.208	0.8		97.5
100.0		0.0105	0.1	0.015	0.2	0.025	0.2	0.051	0.4	0.103	0.5	0.211	0.8		100.0
120.0		0.012	0.2	0.017	0.2	0.028	0.3	0.057	0.4	0.114	0.6	0.234	0.8		120.0
140.0		0.013	0.2	0.018	0.2	0.030	0.3	0.062	0.4	0.125	0.6	0.256	0.8	0.5	140.0
160.0		0.014	0.2	0.020	0.2	0.033	0.3	0.067	0.4	0.135	0.6	0.277	0.8		160.0
180.0		0.015	0.2	0.021	0.2	0.035	0.3	0.072	0.4	0.145	0.6	0.296	0.9		180.0
200.0		0.016	0.2	0.023	0.2	0.038	0.3	0.076	0.4	0.154	0.6	0.315	0.9		200.0
220.0		0.017	0.2	0.024	0.2	0.040	0.3	0.081	0.4	0.162	0.6	0.332	0.9		220.0
240.0	0.3	0.018	0.2	0.025	0.2	0.042	0.3	0.085	0.4	0.171	0.6	0.349	0.9		240.0
260.0		0.019	0.2	0.027	0.2	0.044	0.3	0.089	0.4	0.179	0.6	0.366	0.9		260.0
280.0		0.019	0.2	0.028	0.2	0.046	0.3	0.093	0.4	0.187	0.6	0.382	0.9		280.0
300.0		0.020	0.2	0.029	0.2	0.048	0.3	0.097	0.4	0.194	0.6	0.397	0.9		300.0
320.0		0.021	0.2	0.030	0.2	0.050	0.3	0.100	0.4	0.202	0.6	0.412	0.9		320.0
340.0		0.022	0.2	0.031	0.2	0.051	0.3	0.104	0.4	0.209	0.6	0.426	0.9		340.0
360.0		0.023	0.2	0.032	0.2	0.053	0.3	0.108	0.5	0.216	0.7	0.441	1.0		360.0
380.0		0.023	0.2	0.033	0.2	0.055	0.3	0.111	0.5	0.223	0.7	0.454	1.0		380.0
400.0		0.024	0.2	0.034	0.2	0.057	0.3	0.114	0.5	0.229	0.7	0.468	1.0		400.0
420.0		0.025	0.2	0.035	0.2	0.058	0.3	0.118	0.5	0.236	0.7	0.481	1.0		420.0
440.0		0.025	0.2	0.036	0.2	0.060	0.3	0.121	0.5	0.242	0.7	0.494	1.0		440.0
460.0		0.026	0.2	0.037	0.2	0.061	0.3	0.124	0.5	0.248	0.7	0.507	1.0		460.0
480.0		0.027	0.2	0.038	0.2	0.063	0.3	0.127	0.5	0.255	0.7	0.519	1.0	1.0	480.0
500.0		0.027	0.2	0.039	0.2	0.064	0.3	0.130	0.5	0.261	0.7	0.531	1.0		500.0
520.0		0.028	0.2	0.040	0.2	0.066	0.3	0.133	0.5	0.267	0.7	0.543	1.0		520.0
540.0		0.029	0.2	0.041	0.2	0.067	0.3	0.136	0.5	0.272	0.7	0.555	1.0		540.0
560.0		0.029	0.2	0.042	0.3	0.069	0.3	0.139	0.5	0.278	0.7	0.567	1.0		560.0
580.0	0.5	0.030	0.2	0.043	0.3	0.070	0.3	0.142	0.5	0.284	0.7	0.578	1.0		580.0
600.0		0.030	0.2	0.043	0.3	0.072	0.3	0.144	0.5	0.289	0.7	0.590	1.0		600.0
620.0		0.031	0.2	0.044	0.3	0.073	0.3	0.147	0.5	0.295	0.7	0.601	1.0		620.0
640.0		0.032	0.2	0.045	0.3	0.074	0.3	0.150	0.5	0.300	0.7	0.612	1.0		640.0
660.0		0.032	0.2	0.046	0.3	0.076	0.3	0.153	0.5	0.306	0.7	0.622	1.0		660.0
680.0		0.033	0.2	0.047	0.3	0.077	0.3	0.155	0.5	0.311	0.7	0.633	1.0		680.0
700.0		0.033	0.2	0.047	0.3	0.078	0.3	0.158	0.5	0.316	0.7	0.644	1.0		700.0
720.0		0.034	0.2	0.048	0.3	0.080	0.3	0.160	0.5	0.321	0.7	0.654	1.1		720.0
740.0		0.034	0.2	0.049	0.3	0.081	0.3	0.163	0.5	0.326	0.7	0.664	1.1		740.0
760.0		0.035	0.2	0.050	0.3	0.082	0.3	0.166	0.5	0.331	0.7	0.674	1.1		760.0
780.0		0.036	0.2	0.051	0.3	0.083	0.3	0.168	0.5	0.336	0.7	0.684	1.1		780.0
800.0		0.036	0.2	0.051	0.3	0.085	0.4	0.171	0.5	0.341	0.7	0.694	1.1		800.0
820.0		0.037	0.2	0.052	0.3	0.086	0.4	0.173	0.5	0.346	0.7	0.704	1.1		820.0
840.0		0.037	0.2	0.053	0.3	0.087	0.4	0.175	0.5	0.351	0.7	0.714	1.1		840.0
860.0		0.038	0.2	0.054	0.3	0.088	0.4	0.178	0.5	0.355	0.7	0.723	1.1		860.0
880.0		0.038	0.2	0.054	0.3	0.090	0.4	0.180	0.5	0.360	0.7	0.733	1.1		880.0
900.0		0.039	0.2	0.055	0.3	0.091	0.4	0.182	0.5	0.365	0.7	0.742	1.1		900.0
920.0		0.039	0.2	0.056	0.3	0.092	0.4	0.185	0.5	0.369	0.8	0.751	1.1		920.0
940.0		0.040	0.2	0.056	0.3	0.093	0.4	0.187	0.5	0.374	0.8	0.761	1.1		940.0
960.0		0.040	0.2	0.057	0.3	0.094	0.4	0.189	0.5	0.379	0.8	0.770	1.1		960.0
980.0		0.041	0.2	0.058	0.3	0.095	0.4	0.192	0.5	0.383	0.8	0.779	1.1		980.0
1000.0		0.041	0.2	0.058	0.3	0.096	0.4	0.194	0.5	0.387	0.8	0.788	1.1	1.5	1000.0
1100.0		0.043	0.2	0.062	0.3	0.102	0.4	0.205	0.5	0.409	0.8	0.831	1.1		1100.0
1200.0		0.046	0.2	0.065	0.3	0.107	0.4	0.215	0.5	0.430	0.8	0.873	1.1		1200.0
1300.0		0.048	0.2	0.068	0.3	0.112	0.4	0.225	0.5	0.450	0.8	0.914	1.1		1300.0
1400.0		0.050	0.2	0.071	0.3	0.117	0.4	0.235	0.6	0.469	0.8	0.953	1.2		1400.0
1500.0		0.052	0.2	0.074	0.3	0.122	0.4	0.245	0.6	0.488	0.8	0.991	1.2		1500.0
1600.0		0.054	0.2	0.077	0.3	0.126	0.4	0.254	0.6	0.506	0.8	1.028	1.2	2.0	1600.0

M = mass flow rate kg/s l_e = equivalent length of pipe m Δp_l = pressure loss per unit length Pa/m v = velocity m/s

Flow of water at 10 deg C

Δp_l	v	12 mm		14 mm		16 mm		20 mm		25 mm		32 mm		v	Δp_l
		M	l_e	M	l_e	M	l_e	M	l_e	M	l_e	M	l_e		
1600.0	1.0	0.054	0.2	0.077	0.3	0.126	0.4	0.254	0.6	0.506	0.8	1.028	1.2	1700.0	
1700.0		0.056	0.2	0.080	0.3	0.131	0.4	0.263	0.6	0.524	0.8	1.063	1.2		
1800.0		0.058	0.3	0.082	0.3	0.135	0.4	0.271	0.6	0.541	0.8	1.098	1.2		
1900.0		0.060	0.3	0.085	0.3	0.140	0.4	0.280	0.6	0.558	0.8	1.132	1.2		
2000.0		0.062	0.3	0.087	0.3	0.144	0.4	0.288	0.6	0.574	0.8	1.165	1.2		
2100.0		0.063	0.3	0.090	0.3	0.148	0.4	0.296	0.6	0.591	0.8	1.198	1.2		
2200.0		0.065	0.3	0.092	0.3	0.152	0.4	0.304	0.6	0.606	0.8	1.229	1.2		
2300.0		0.067	0.3	0.095	0.3	0.156	0.4	0.312	0.6	0.622	0.9	1.261	1.2		
2400.0		0.068	0.3	0.097	0.3	0.160	0.4	0.320	0.6	0.637	0.9	1.291	1.2		
2500.0		0.070	0.3	0.099	0.3	0.163	0.4	0.327	0.6	0.652	0.9	1.321	1.2		
2600.0	1.5	0.072	0.3	0.102	0.3	0.167	0.4	0.335	0.6	0.666	0.9	1.351	1.2	2600.0	
2700.0		0.073	0.3	0.104	0.3	0.171	0.4	0.342	0.6	0.681	0.9	1.379	1.2		
2800.0		0.075	0.3	0.106	0.3	0.174	0.4	0.349	0.6	0.695	0.9	1.408	1.3		
2900.0		0.076	0.3	0.108	0.3	0.178	0.4	0.356	0.6	0.709	0.9	1.436	1.3		
3000.0		0.078	0.3	0.110	0.3	0.181	0.4	0.363	0.6	0.723	0.9	1.464	1.3		
3100.0		0.079	0.3	0.113	0.3	0.185	0.4	0.370	0.6	0.736	0.9	1.491	1.3		
3200.0		0.081	0.3	0.115	0.3	0.188	0.4	0.377	0.6	0.749	0.9	1.518	1.3		
3300.0		0.082	0.3	0.117	0.3	0.192	0.4	0.383	0.6	0.762	0.9	1.544	1.3		
3400.0		0.084	0.3	0.119	0.3	0.195	0.4	0.390	0.6	0.775	0.9	1.570	1.3		
3500.0		0.085	0.3	0.121	0.3	0.198	0.4	0.396	0.6	0.788	0.9	1.596	1.3		
3600.0	2.0	0.087	0.3	0.123	0.3	0.201	0.4	0.403	0.6	0.801	0.9	1.621	1.3	3600.0	
3700.0		0.088	0.3	0.125	0.3	0.204	0.4	0.409	0.6	0.813	0.9	1.646	1.3		
3800.0		0.089	0.3	0.126	0.3	0.208	0.4	0.415	0.6	0.826	0.9	1.671	1.3		
3900.0		0.091	0.3	0.128	0.3	0.211	0.4	0.421	0.6	0.838	0.9	1.696	1.3		
4000.0		0.092	0.3	0.130	0.3	0.214	0.4	0.427	0.6	0.850	0.9	1.720	1.3		
4100.0		0.093	0.3	0.132	0.3	0.217	0.4	0.433	0.6	0.862	0.9	1.744	1.3		
4200.0		0.095	0.3	0.134	0.3	0.220	0.4	0.439	0.6	0.873	0.9	1.767	1.3		
4300.0		0.096	0.3	0.136	0.3	0.223	0.5	0.445	0.6	0.885	0.9	1.791	1.3		
4400.0		0.097	0.3	0.138	0.3	0.226	0.5	0.451	0.6	0.897	0.9	1.814	1.3		
4500.0		0.098	0.3	0.139	0.3	0.229	0.5	0.457	0.7	0.908	0.9	1.837	1.3		
4600.0	2.5	0.100	0.3	0.141	0.4	0.231	0.5	0.463	0.7	0.919	0.9	1.860	1.3	4600.0	
4700.0		0.101	0.3	0.143	0.4	0.234	0.5	0.468	0.7	0.931	0.9	1.882	1.3		
4800.0		0.102	0.3	0.145	0.4	0.237	0.5	0.474	0.7	0.942	0.9	1.905	1.3		
4900.0		0.103	0.3	0.146	0.4	0.240	0.5	0.479	0.7	0.953	0.9	1.927	1.3		
5000.0		0.105	0.3	0.148	0.4	0.243	0.5	0.485	0.7	0.964	0.9	1.949	1.3		
5100.0		0.106	0.3	0.150	0.4	0.245	0.5	0.490	0.7	0.974	0.9	1.970	1.3		
5200.0		0.107	0.3	0.151	0.4	0.248	0.5	0.496	0.7	0.985	0.9	1.992	1.4		
5300.0		0.108	0.3	0.153	0.4	0.251	0.5	0.501	0.7	0.996	0.9	2.013	1.4		
5400.0		0.109	0.3	0.155	0.4	0.254	0.5	0.506	0.7	1.006	0.9	2.034	1.4		
5500.0		0.110	0.3	0.156	0.4	0.256	0.5	0.512	0.7	1.017	1.0	2.055	1.4		
5600.0	3.0	0.112	0.3	0.158	0.4	0.259	0.5	0.517	0.7	1.027	1.0	2.076	1.4	5600.0	
5700.0		0.113	0.3	0.160	0.4	0.262	0.5	0.522	0.7	1.037	1.0	2.097	1.4		
5800.0		0.114	0.3	0.161	0.4	0.264	0.5	0.527	0.7	1.047	1.0	2.117	1.4		
5900.0		0.115	0.3	0.163	0.4	0.267	0.5	0.532	0.7	1.057	1.0	2.138	1.4		
6000.0		0.116	0.3	0.164	0.4	0.269	0.5	0.538	0.7	1.067	1.0	2.158	1.4		
6100.0		0.117	0.3	0.166	0.4	0.272	0.5	0.543	0.7	1.077	1.0	2.178	1.4		
6200.0		0.118	0.3	0.167	0.4	0.274	0.5	0.548	0.7	1.087	1.0	2.198	1.4		
6300.0		0.119	0.3	0.169	0.4	0.277	0.5	0.553	0.7	1.097	1.0	2.217	1.4		
6400.0		0.120	0.3	0.170	0.4	0.279	0.5	0.557	0.7	1.107	1.0	2.237	1.4		
6500.0		0.121	0.3	0.172	0.4	0.282	0.5	0.562	0.7	1.117	1.0	2.256	1.4		
6600.0	3.5	0.123	0.3	0.173	0.4	0.284	0.5	0.567	0.7	1.126	1.0	2.276	1.4	6600.0	
6700.0		0.124	0.3	0.175	0.4	0.287	0.5	0.572	0.7	1.136	1.0	2.295	1.4		
6800.0		0.125	0.3	0.176	0.4	0.289	0.5	0.577	0.7	1.145	1.0	2.314	1.4		
6900.0		0.126	0.3	0.178	0.4	0.291	0.5	0.582	0.7	1.155	1.0	2.333	1.4		
7000.0		0.127	0.3	0.179	0.4	0.294	0.5	0.586	0.7	1.164	1.0	2.352	1.4		
7100.0		0.128	0.3	0.181	0.4	0.296	0.5	0.591	0.7	1.173	1.0	2.370	1.4		
7200.0		0.129	0.3	0.182	0.4	0.299	0.5	0.596	0.7	1.182	1.0	2.389	1.4		
7300.0		0.130	0.3	0.184	0.4	0.301	0.5	0.600	0.7	1.192	1.0	2.407	1.4		
7400.0		0.131	0.3	0.185	0.4	0.303	0.5	0.605	0.7	1.201	1.0	2.426	1.4		
7500.0		0.132	0.3	0.187	0.4	0.306	0.5	0.610	0.7	1.210	1.0	2.444	1.4		

M = mass flow rate **kg/s** **l_e** = equivalent length of pipe **m** **Δp_l** = pressure loss per unit length **Pa/m** **v** = velocity **m/s**

Flow of water at 10 deg C

Δp_l	v	40 mm		50 mm		63 mm		75 mm		90 mm		110 mm		v	Δp_l
		M	l_e	M	l_e	M	l_e	M	l_e	M	l_e	M	l_e		
0.1		0.006	0.2	0.012	0.4	0.022	0.6	0.035	0.8	0.062	1.1	0.112	1.5		0.1
0.2		0.009	0.3	0.018	0.5	0.034	0.7	0.054	0.9	0.094	1.3	0.169	1.8		0.2
0.3		0.011	0.3	0.023	0.5	0.044	0.8	0.069	1.0	0.120	1.4	0.215	1.9		0.3
0.4		0.014	0.4	0.028	0.6	0.052	0.8	0.082	1.1	0.143	1.5	0.256	2.0		0.4
0.5		0.016	0.4	0.032	0.6	0.060	0.9	0.094	1.1	0.163	1.5	0.292	2.1	0.05	0.5
0.6		0.018	0.4	0.036	0.6	0.067	0.9	0.105	1.2	0.182	1.6	0.325	2.2		0.6
0.7		0.020	0.4	0.040	0.6	0.073	0.9	0.115	1.2	0.199	1.6	0.355	2.2		0.7
0.8		0.021	0.4	0.043	0.7	0.079	0.9	0.125	1.2	0.215	1.7	0.384	2.3		0.8
0.9		0.023	0.4	0.046	0.7	0.085	1.0	0.134	1.2	0.231	1.7	0.412	2.3		0.9
1.0		0.024	0.5	0.049	0.7	0.091	1.0	0.143	1.3	0.246	1.7	0.438	2.4		1.0
1.5		0.031	0.5	0.063	0.8	0.115	1.1	0.181	1.4	0.312	1.8	0.555	2.5		1.5
2.0	0.05	0.037	0.5	0.075	0.8	0.137	1.1	0.215	1.4	0.369	1.9	0.656	2.7		2.0
2.5		0.043	0.6	0.085	0.8	0.156	1.2	0.245	1.5	0.420	2.0	0.746	2.8		2.5
3.0		0.047	0.6	0.095	0.9	0.174	1.2	0.273	1.5	0.467	2.1	0.829	2.8		3.0
3.5		0.052	0.6	0.104	0.9	0.190	1.2	0.298	1.6	0.511	2.1	0.906	2.9	0.15	3.5
4.0		0.056	0.6	0.113	0.9	0.206	1.3	0.322	1.6	0.552	2.2	0.979	3.0		4.0
4.5		0.061	0.6	0.121	0.9	0.221	1.3	0.345	1.7	0.591	2.2	1.047	3.0		4.5
5.0		0.064	0.6	0.128	0.9	0.235	1.3	0.367	1.7	0.628	2.3	1.113	3.1		5.0
5.5		0.068	0.7	0.136	1.0	0.248	1.3	0.388	1.7	0.664	2.3	1.175	3.1		5.5
6.0		0.072	0.7	0.143	1.0	0.261	1.4	0.408	1.7	0.698	2.3	1.235	3.1		6.0
6.5		0.075	0.7	0.150	1.0	0.274	1.4	0.428	1.8	0.731	2.3	1.293	3.2		6.5
7.0		0.079	0.7	0.157	1.0	0.286	1.4	0.446	1.8	0.763	2.4	1.349	3.2		7.0
7.5		0.082	0.7	0.163	1.0	0.298	1.4	0.465	1.8	0.794	2.4	1.404	3.2		7.5
8.0		0.085	0.7	0.169	1.0	0.309	1.4	0.482	1.8	0.824	2.4	1.457	3.3		8.0
8.5		0.088	0.7	0.176	1.0	0.320	1.4	0.500	1.8	0.853	2.4	1.508	3.3		8.5
9.0		0.091	0.7	0.182	1.0	0.331	1.5	0.516	1.9	0.882	2.5	1.558	3.3		9.0
9.5		0.094	0.7	0.187	1.1	0.341	1.5	0.533	1.9	0.910	2.5	1.607	3.4		9.5
10.0		0.097	0.7	0.193	1.1	0.352	1.5	0.549	1.9	0.937	2.5	1.655	3.4		10.0
12.5	0.15	0.111	0.8	0.220	1.1	0.400	1.5	0.624	1.9	1.065	2.6	1.879	3.5	0.3	12.5
15.0		0.124	0.8	0.245	1.1	0.445	1.6	0.693	2.0	1.182	2.7	2.085	3.6		15.0
17.5		0.135	0.8	0.268	1.2	0.486	1.6	0.757	2.0	1.291	2.7	2.275	3.7		17.5
20.0		0.146	0.8	0.289	1.2	0.525	1.7	0.818	2.1	1.393	2.8	2.455	3.7		20.0
22.5		0.157	0.8	0.310	1.2	0.562	1.7	0.875	2.1	1.489	2.8	2.624	3.8		22.5
25.0		0.167	0.9	0.329	1.2	0.597	1.7	0.929	2.2	1.582	2.9	2.786	3.8		25.0
27.5		0.176	0.9	0.348	1.3	0.631	1.7	0.981	2.2	1.670	2.9	2.940	3.9		27.5
30.0		0.185	0.9	0.366	1.3	0.663	1.8	1.031	2.2	1.754	2.9	3.088	3.9	0.5	30.0
32.5		0.194	0.9	0.383	1.3	0.694	1.8	1.079	2.2	1.836	3.0	3.231	4.0		32.5
35.0		0.203	0.9	0.400	1.3	0.724	1.8	1.126	2.3	1.915	3.0	3.370	4.0		35.0
37.5		0.211	0.9	0.416	1.3	0.753	1.8	1.171	2.3	1.991	3.0	3.503	4.0		37.5
40.0		0.219	0.9	0.432	1.3	0.782	1.8	1.215	2.3	2.066	3.0	3.633	4.1		40.0
42.5		0.227	0.9	0.447	1.3	0.809	1.8	1.258	2.3	2.138	3.1	3.760	4.1		42.5
45.0	0.3	0.235	0.9	0.462	1.4	0.836	1.9	1.299	2.3	2.208	3.1	3.883	4.1		45.0
47.5		0.242	1.0	0.476	1.4	0.863	1.9	1.340	2.4	2.277	3.1	4.003	4.2		47.5
50.0		0.249	1.0	0.491	1.4	0.888	1.9	1.380	2.4	2.344	3.1	4.121	4.2		50.0
52.5		0.257	1.0	0.505	1.4	0.913	1.9	1.419	2.4	2.410	3.2	4.235	4.2		52.5
55.0		0.264	1.0	0.518	1.4	0.938	1.9	1.457	2.4	2.474	3.2	4.348	4.2		55.0
57.5		0.270	1.0	0.532	1.4	0.962	1.9	1.494	2.4	2.537	3.2	4.458	4.3		57.5
60.0		0.277	1.0	0.545	1.4	0.986	1.9	1.530	2.4	2.599	3.2	4.566	4.3		60.0
62.5		0.284	1.0	0.558	1.4	1.009	2.0	1.566	2.5	2.659	3.2	4.672	4.3		62.5
65.0		0.290	1.0	0.570	1.4	1.032	2.0	1.602	2.5	2.719	3.2	4.776	4.3		65.0
67.5		0.297	1.0	0.583	1.4	1.054	2.0	1.636	2.5	2.778	3.3	4.879	4.4		67.5
70.0		0.303	1.0	0.595	1.5	1.076	2.0	1.670	2.5	2.835	3.3	4.980	4.4		70.0
72.5		0.309	1.0	0.607	1.5	1.098	2.0	1.704	2.5	2.892	3.3	5.079	4.4		72.5
75.0		0.315	1.0	0.619	1.5	1.119	2.0	1.737	2.5	2.948	3.3	5.176	4.4		75.0
77.5		0.321	1.0	0.631	1.5	1.140	2.0	1.770	2.5	3.003	3.3	5.273	4.4		77.5

M = mass flow rate kg/s l_e = equivalent length of pipe m Δp_l = pressure loss per unit length Pa/m v = velocity m/s

Flow of water at 10 deg C

Δp_l	v	40 mm		50 mm		63 mm		75 mm		90 mm		110 mm		v	Δp_l
		M	l_e	M	l_e	M	l_e	M	l_e	M	l_e	M	l_e		
80.0		0.327	1.0	0.642	1.5	1.16	2.0	1.80	2.5	3.06	3.3	5.37	4.4		80.0
82.5		0.333	1.0	0.654	1.5	1.18	2.0	1.83	2.5	3.11	3.3	5.46	4.5		82.5
85.0		0.339	1.0	0.665	1.5	1.20	2.0	1.86	2.6	3.16	3.4	5.55	4.5		85.0
87.5		0.344	1.0	0.676	1.5	1.22	2.0	1.90	2.6	3.22	3.4	5.64	4.5		87.5
90.0		0.350	1.1	0.687	1.5	1.24	2.1	1.93	2.6	3.27	3.4	5.73	4.5		90.0
92.5		0.356	1.1	0.698	1.5	1.26	2.1	1.96	2.6	3.32	3.4	5.82	4.5		92.5
95.0		0.361	1.1	0.709	1.5	1.28	2.1	1.99	2.6	3.37	3.4	5.91	4.5		95.0
97.5		0.367	1.1	0.719	1.5	1.30	2.1	2.02	2.6	3.42	3.4	6.00	4.6		97.5
100.0	0.5	0.372	1.1	0.730	1.5	1.32	2.1	2.04	2.6	3.47	3.4	6.08	4.6	1.0	100.0
120.0		0.413	1.1	0.810	1.6	1.46	2.1	2.27	2.7	3.84	3.5	6.74	4.7		120.0
140.0		0.451	1.1	0.884	1.6	1.60	2.2	2.47	2.7	4.19	3.6	7.34	4.8		140.0
160.0		0.487	1.1	0.954	1.6	1.72	2.2	2.67	2.8	4.52	3.6	7.91	4.8		160.0
180.0		0.521	1.2	1.020	1.7	1.84	2.2	2.85	2.8	4.82	3.7	8.45	4.9		180.0
200.0		0.553	1.2	1.083	1.7	1.95	2.3	3.02	2.9	5.12	3.7	8.96	5.0		200.0
220.0		0.584	1.2	1.143	1.7	2.06	2.3	3.19	2.9	5.40	3.8	9.45	5.0	1.5	220.0
240.0		0.614	1.2	1.201	1.7	2.16	2.3	3.35	2.9	5.67	3.8	9.92	5.1		240.0
260.0		0.643	1.2	1.256	1.7	2.26	2.4	3.50	2.9	5.93	3.9	10.38	5.1		260.0
280.0		0.670	1.2	1.310	1.8	2.36	2.4	3.65	3.0	6.18	3.9	10.81	5.2		280.0
300.0		0.697	1.3	1.362	1.8	2.45	2.4	3.80	3.0	6.42	3.9	11.24	5.2		300.0
320.0		0.723	1.3	1.413	1.8	2.54	2.4	3.94	3.0	6.66	4.0	11.65	5.2		320.0
340.0		0.749	1.3	1.462	1.8	2.63	2.4	4.07	3.0	6.89	4.0	12.05	5.3		340.0
360.0		0.773	1.3	1.510	1.8	2.72	2.5	4.20	3.1	7.11	4.0	12.44	5.3	2.0	360.0
380.0	1.0	0.798	1.3	1.557	1.8	2.80	2.5	4.33	3.1	7.33	4.0	12.82	5.3		380.0
400.0		0.821	1.3	1.603	1.8	2.88	2.5	4.46	3.1	7.54	4.1	13.19	5.4		400.0
420.0		0.844	1.3	1.648	1.9	2.96	2.5	4.58	3.1	7.75	4.1	13.55	5.4		420.0
440.0		0.867	1.3	1.691	1.9	3.04	2.5	4.70	3.1	7.95	4.1	13.90	5.4		440.0
460.0		0.889	1.3	1.734	1.9	3.12	2.5	4.82	3.2	8.15	4.1	14.25	5.5		460.0
480.0		0.911	1.3	1.777	1.9	3.19	2.5	4.94	3.2	8.35	4.1	14.59	5.5		480.0
500.0		0.932	1.3	1.818	1.9	3.27	2.6	5.05	3.2	8.54	4.2	14.93	5.5		500.0
520.0		0.953	1.3	1.858	1.9	3.34	2.6	5.16	3.2	8.73	4.2	15.26	5.5		520.0
540.0		0.973	1.4	1.898	1.9	3.41	2.6	5.27	3.2	8.91	4.2	15.58	5.6		540.0
560.0		0.994	1.4	1.938	1.9	3.48	2.6	5.38	3.2	9.09	4.2	15.90	5.6	2.5	560.0
580.0		1.014	1.4	1.976	1.9	3.55	2.6	5.49	3.2	9.27	4.2	16.21	5.6		580.0
600.0		1.033	1.4	2.014	1.9	3.62	2.6	5.59	3.3	9.45	4.2	16.52	5.6		600.0
620.0		1.053	1.4	2.052	1.9	3.69	2.6	5.70	3.3	9.62	4.3	16.82	5.6		620.0
640.0		1.072	1.4	2.089	2.0	3.75	2.6	5.80	3.3	9.79	4.3	17.12	5.7		640.0
660.0		1.091	1.4	2.125	2.0	3.82	2.6	5.90	3.3	9.96	4.3	17.41	5.7		660.0
680.0		1.109	1.4	2.161	2.0	3.88	2.7	6.00	3.3	10.13	4.3	17.70	5.7		680.0
700.0		1.127	1.4	2.197	2.0	3.95	2.7	6.10	3.3	10.30	4.3	17.99	5.7		700.0
720.0		1.146	1.4	2.232	2.0	4.01	2.7	6.19	3.3	10.46	4.3	18.27	5.7		720.0
740.0		1.163	1.4	2.267	2.0	4.07	2.7	6.29	3.3	10.62	4.3	18.55	5.7		740.0
760.0		1.181	1.4	2.301	2.0	4.13	2.7	6.38	3.4	10.78	4.4	18.83	5.8	3.0	760.0
780.0	1.5	1.199	1.4	2.335	2.0	4.19	2.7	6.48	3.4	10.93	4.4	19.10	5.8		780.0
800.0		1.216	1.4	2.368	2.0	4.25	2.7	6.57	3.4	11.09	4.4	19.37	5.8		800.0
820.0		1.233	1.4	2.401	2.0	4.31	2.7	6.66	3.4	11.24	4.4	19.64	5.8		820.0
840.0		1.250	1.4	2.434	2.0	4.37	2.7	6.75	3.4	11.39	4.4	19.90	5.8		840.0
860.0		1.266	1.4	2.466	2.0	4.43	2.7	6.84	3.4	11.54	4.4	20.16	5.8		860.0
880.0		1.283	1.4	2.498	2.0	4.48	2.7	6.93	3.4	11.69	4.4	20.42	5.9		880.0
900.0		1.299	1.4	2.530	2.0	4.54	2.7	7.01	3.4	11.84	4.4	20.67	5.9		900.0
920.0		1.316	1.5	2.561	2.0	4.60	2.8	7.10	3.4	11.98	4.5	20.93	5.9		920.0
940.0		1.332	1.5	2.592	2.0	4.65	2.8	7.19	3.4	12.13	4.5	21.18	5.9		940.0
960.0		1.347	1.5	2.623	2.1	4.71	2.8	7.27	3.4	12.27	4.5	21.42	5.9		960.0
980.0		1.363	1.5	2.654	2.1	4.76	2.8	7.35	3.4	12.41	4.5	21.67	5.9		980.0
1000.0		1.379	1.5	2.684	2.1	4.82	2.8	7.44	3.5	12.55	4.5	21.91	5.9		1000.0
1100.0		1.455	1.5	2.831	2.1	5.08	2.8	7.84	3.5	13.23	4.5	23.10	6.0		1100.0
1200.0		1.528	1.5	2.972	2.1	5.33	2.8	8.23	3.5	13.88	4.6	24.24	6.0		1200.0
1300.0	2.0	1.598	1.5	3.109	2.1	5.58	2.9	8.61	3.6	14.51	4.6	25.33	6.1		1300.0
1400.0		1.666	1.5	3.240	2.2	5.81	2.9	8.97	3.6	15.12	4.7	26.39	6.1		1400.0
1500.0		1.732	1.5	3.368	2.2	6.04	2.9	9.32	3.6	15.71	4.7	27.41	6.2		1500.0
1600.0		1.796	1.6	3.491	2.2	6.26	2.9	9.66	3.6	16.28	4.7	28.40	6.2		1600.0

M = mass flow rate **kg/s** **l_e** = equivalent length of pipe **m** **Δp_l** = pressure loss per unit length **Pa/m** **v** = velocity **m/s**

Flow of water at 10 deg C

Δp_l	v	40 mm		50 mm		63 mm		75 mm		90 mm		110 mm		v	Δp_l
		M	l_e	M	l_e	M	l_e	M	l_e	M	l_e	M	l_e		
1600.0	2.5	1.80	1.6	3.49	2.2	6.26	2.9	9.66	3.6	16.28	4.7	28.40	6.2	1700.0	
1700.0		1.86	1.6	3.61	2.2	6.47	3.0	9.99	3.7	16.84	4.8	29.37	6.3	1800.0	
1800.0		1.92	1.6	3.73	2.2	6.68	3.0	10.31	3.7	17.38	4.8	30.31	6.3	1900.0	
1900.0		1.98	1.6	3.84	2.2	6.89	3.0	10.62	3.7	17.90	4.8	31.23	6.3	2000.0	
2000.0		2.04	1.6	3.95	2.2	7.09	3.0	10.93	3.7	18.42	4.8	32.12	6.4	2100.0	
2100.0	3.0	2.09	1.6	4.06	2.3	7.28	3.0	11.23	3.8	18.92	4.9	33.00	6.4	2100.0	
2200.0		2.15	1.6	4.17	2.3	7.47	3.0	11.52	3.8	19.41	4.9	33.85	6.4	2200.0	
2300.0		2.20	1.6	4.28	2.3	7.66	3.1	11.81	3.8	19.90	4.9	34.69	6.5	2300.0	
2400.0		2.25	1.6	4.38	2.3	7.84	3.1	12.09	3.8	20.37	4.9	35.51	6.5	2400.0	
2500.0		2.31	1.6	4.48	2.3	8.02	3.1	12.37	3.8	20.83	5.0	36.32	6.5	2500.0	
2600.0		2.36	1.7	4.58	2.3	8.20	3.1	12.64	3.8	21.29	5.0	37.11	6.5	2600.0	
2700.0		2.41	1.7	4.67	2.3	8.37	3.1	12.90	3.9	21.74	5.0	37.89	6.6	2700.0	
2800.0		2.46	1.7	4.77	2.3	8.54	3.1	13.17	3.9	22.18	5.0	38.65	6.6	2800.0	
2900.0		2.51	1.7	4.86	2.3	8.71	3.1	13.42	3.9	22.61	5.0	39.40	6.6	2900.0	
3000.0		2.55	1.7	4.96	2.3	8.87	3.1	13.68	3.9	23.04	5.0	40.14	6.6	3000.0	
3100.0		2.60	1.7	5.05	2.4	9.04	3.2	13.93	3.9	23.46	5.1	40.87	6.7	3100.0	
3200.0		2.65	1.7	5.14	2.4	9.20	3.2	14.18	3.9	23.87	5.1	41.59	6.7	3200.0	
3300.0		2.69	1.7	5.23	2.4	9.35	3.2	14.42	3.9	24.28	5.1	42.30	6.7	3300.0	
3400.0		2.74	1.7	5.31	2.4	9.51	3.2	14.66	4.0	24.68	5.1	43.00	6.7	3400.0	
3500.0		2.78	1.7	5.40	2.4	9.66	3.2	14.89	4.0	25.08	5.1	43.69	6.7	3500.0	
3600.0	2.83	1.7	5.49	2.4	9.82	3.2	15.13	4.0	25.47	5.1	44.37	6.8	3600.0		
3700.0	2.87	1.7	5.57	2.4	9.97	3.2	15.36	4.0	25.86	5.2	45.04	6.8	3700.0		
3800.0	2.92	1.7	5.65	2.4	10.12	3.2	15.59	4.0	26.24	5.2	45.71	6.8	3800.0		
3900.0	2.96	1.7	5.74	2.4	10.26	3.2	15.81	4.0	26.62	5.2	46.36	6.8	3900.0		
4000.0	3.00	1.7	5.82	2.4	10.41	3.2	16.03	4.0	26.99	5.2	47.01	6.8	4000.0		
4100.0	3.04	1.7	5.90	2.4	10.55	3.3	16.25	4.0	27.36	5.2	47.65	6.8	4100.0		
4200.0	3.08	1.7	5.98	2.4	10.69	3.3	16.47	4.0	27.73	5.2	48.29	6.9	4200.0		
4300.0	3.12	1.8	6.05	2.4	10.83	3.3	16.69	4.0	28.09	5.2	48.91	6.9	4300.0		
4400.0	3.16	1.8	6.13	2.5	10.97	3.3	16.90	4.1	28.44	5.2	49.54	6.9	4400.0		
4500.0	3.20	1.8	6.21	2.5	11.11	3.3	17.11	4.1	28.80	5.3	50.15	6.9	4500.0		
4600.0	3.24	1.8	6.29	2.5	11.24	3.3	17.32	4.1	29.15	5.3	50.76	6.9	4600.0		
4700.0	3.28	1.8	6.36	2.5	11.38	3.3	17.53	4.1	29.49	5.3	51.36	6.9	4700.0		
4800.0	3.32	1.8	6.44	2.5	11.51	3.3	17.73	4.1	29.84	5.3	51.95	6.9	4800.0		
4900.0	3.36	1.8	6.51	2.5	11.64	3.3	17.93	4.1	30.18	5.3	52.54	7.0	4900.0		
5000.0	3.40	1.8	6.58	2.5	11.77	3.3	18.13	4.1	30.51	5.3	53.13	7.0	5000.0		
5100.0	3.43	1.8	6.66	2.5	11.90	3.3	18.33	4.1	30.85	5.3	53.71	7.0	5100.0		
5200.0	3.47	1.8	6.73	2.5	12.03	3.3	18.53	4.1	31.18	5.3	54.28	7.0	5200.0		
5300.0	3.51	1.8	6.80	2.5	12.16	3.3	18.73	4.1	31.51	5.3	54.85	7.0	5300.0		
5400.0	3.55	1.8	6.87	2.5	12.28	3.3	18.92	4.1	31.83	5.4	55.42	7.0	5400.0		
5500.0	3.58	1.8	6.94	2.5	12.41	3.4	19.11	4.2	32.15	5.4	55.98	7.0	5500.0		
5600.0	3.62	1.8	7.01	2.5	12.53	3.4	19.30	4.2	32.47	5.4	56.53	7.0	5600.0		
5700.0	3.65	1.8	7.08	2.5	12.66	3.4	19.49	4.2	32.79	5.4	57.08	7.1	5700.0		
5800.0	3.69	1.8	7.15	2.5	12.78	3.4	19.68	4.2	33.11	5.4	57.63	7.1	5800.0		
5900.0	3.72	1.8	7.22	2.5	12.90	3.4	19.87	4.2	33.42	5.4	58.17	7.1	5900.0		
6000.0	3.76	1.8	7.28	2.5	13.02	3.4	20.05	4.2	33.73	5.4	58.71	7.1	6000.0		
6100.0	3.79	1.8	7.35	2.5	13.14	3.4	20.23	4.2	34.04	5.4	59.24	7.1	6100.0		
6200.0	3.83	1.8	7.42	2.5	13.26	3.4	20.41	4.2	34.34	5.4	59.77	7.1	6200.0		
6300.0	3.86	1.8	7.48	2.5	13.38	3.4	20.60	4.2	34.64	5.4	60.30	7.1	6300.0		
6400.0	3.90	1.8	7.55	2.6	13.49	3.4	20.77	4.2	34.94	5.4	60.82	7.1	6400.0		
6500.0	3.93	1.8	7.61	2.6	13.61	3.4	20.95	4.2	35.24	5.5	61.34	7.1	6500.0		
6600.0	3.96	1.8	7.68	2.6	13.72	3.4	21.13	4.2	35.54	5.5	61.85	7.2	6600.0		
6700.0	4.00	1.8	7.74	2.6	13.84	3.4	21.31	4.2	35.83	5.5	62.36	7.2	6700.0		
6800.0	4.03	1.8	7.81	2.6	13.95	3.4	21.48	4.2	36.13	5.5	62.87	7.2	6800.0		
6900.0	4.06	1.8	7.87	2.6	14.06	3.4	21.65	4.2	36.42	5.5	63.37	7.2	6900.0		
7000.0	4.10	1.9	7.93	2.6	14.18	3.4	21.82	4.3	36.70	5.5	63.87	7.2	7000.0		
7100.0	4.13	1.9	8.00	2.6	14.29	3.4	22.00	4.3	36.99	5.5	64.37	7.2	7100.0		
7200.0	4.16	1.9	8.06	2.6	14.40	3.4	22.17	4.3	37.28	5.5	64.86	7.2	7200.0		
7300.0	4.19	1.9	8.12	2.6	14.51	3.5	22.33	4.3	37.56	5.5	65.36	7.2	7300.0		
7400.0	4.23	1.9	8.18	2.6	14.62	3.5	22.50	4.3	37.84	5.5	65.84	7.2	7400.0		
7500.0	4.26	1.9	8.24	2.6	14.73	3.5	22.67	4.3	38.12	5.5	66.33	7.2	7500.0		

M = mass flow rate **kg/s** **l_e** = equivalent length of pipe **m** **Δp_l** = pressure loss per unit length **Pa/m** **v** = velocity **m/s**

Calculation basis for radiator connection

Hot water pipe sizing table

Flow of water at 75 deg C

Δp_l	v	12 mm		14 mm		16 mm		20 mm		25 mm		32 mm		v	Δp_l
		M	l_e	M	l_e	M	l_e	M	l_e	M	l_e	M	l_e		
0.1								0.001	0.1	0.002	0.2	0.004	0.3		0.1
0.2						0.0007	0.1	0.001	0.2	0.003	0.3	0.007	0.4		0.2
0.3						0.0009	0.1	0.002	0.2	0.004	0.3	0.008	0.4		0.3
0.4				0.0006	0.1	0.0011	0.1	0.002	0.2	0.005	0.3	0.010	0.5		0.4
0.5				0.0007	0.1	0.0013	0.1	0.003	0.2	0.005	0.3	0.011	0.5		0.5
0.6				0.0008	0.1	0.0014	0.1	0.003	0.2	0.006	0.3	0.013	0.5		0.6
0.7		0.0006	0.1	0.0009	0.1	0.0016	0.1	0.003	0.2	0.007	0.3	0.014	0.5		0.7
0.8		0.0007	0.1	0.0010	0.1	0.0017	0.1	0.004	0.2	0.007	0.3	0.015	0.5		0.8
0.9		0.0007	0.1	0.0011	0.1	0.0018	0.1	0.004	0.2	0.008	0.4	0.016	0.5		0.9
1.0		0.0008	0.1	0.0012	0.1	0.0020	0.2	0.004	0.2	0.008	0.4	0.017	0.5		1.0
1.5		0.0010	0.1	0.0015	0.1	0.0025	0.2	0.005	0.3	0.011	0.4	0.022	0.6		1.5
2.0		0.0012	0.1	0.0018	0.1	0.0030	0.2	0.006	0.3	0.013	0.4	0.026	0.6	0.05	2.0
2.5		0.0014	0.1	0.0020	0.1	0.0034	0.2	0.007	0.3	0.014	0.4	0.030	0.6		2.5
3.0		0.0016	0.1	0.0023	0.1	0.0038	0.2	0.008	0.3	0.016	0.4	0.033	0.7		3.0
3.5		0.0017	0.1	0.0025	0.2	0.0042	0.2	0.009	0.3	0.018	0.5	0.036	0.7		3.5
4.0		0.0019	0.1	0.0027	0.2	0.0046	0.2	0.009	0.3	0.019	0.5	0.039	0.7		4.0
4.5		0.0020	0.1	0.0029	0.2	0.0049	0.2	0.010	0.3	0.020	0.5	0.042	0.7		4.5
5.0		0.0022	0.1	0.0031	0.2	0.0052	0.2	0.011	0.3	0.022	0.5	0.045	0.7		5.0
5.5		0.0023	0.1	0.0033	0.2	0.0055	0.2	0.011	0.3	0.023	0.5	0.047	0.7		5.5
6.0		0.0024	0.1	0.0035	0.2	0.0058	0.2	0.012	0.3	0.024	0.5	0.050	0.7		6.0
6.5		0.0026	0.1	0.0037	0.2	0.0061	0.2	0.012	0.3	0.025	0.5	0.052	0.8		6.5
7.0		0.0027	0.1	0.0038	0.2	0.0064	0.2	0.013	0.3	0.026	0.5	0.054	0.8		7.0
7.5		0.0028	0.1	0.0040	0.2	0.0067	0.2	0.014	0.4	0.027	0.5	0.056	0.8		7.5
8.0		0.0029	0.1	0.0042	0.2	0.0069	0.2	0.014	0.4	0.029	0.5	0.059	0.8		8.0
8.5	0.05	0.0030	0.1	0.0043	0.2	0.0072	0.2	0.015	0.4	0.030	0.5	0.061	0.8		8.5
9.0		0.0031	0.1	0.0045	0.2	0.0074	0.2	0.015	0.4	0.031	0.5	0.063	0.8		9.0
9.5		0.0032	0.2	0.0046	0.2	0.0077	0.2	0.016	0.4	0.032	0.5	0.065	0.8		9.5
10.0		0.0033	0.2	0.0048	0.2	0.0079	0.3	0.016	0.4	0.032	0.5	0.067	0.8		10.0
12.5		0.0038	0.2	0.0054	0.2	0.0090	0.3	0.018	0.4	0.037	0.6	0.076	0.8	0.15	12.5
15.0		0.0042	0.2	0.0061	0.2	0.0101	0.3	0.020	0.4	0.041	0.6	0.084	0.9		15.0
17.5		0.0046	0.2	0.0066	0.2	0.0110	0.3	0.022	0.4	0.045	0.6	0.092	0.9		17.5
20.0		0.0050	0.2	0.0072	0.2	0.0119	0.3	0.024	0.4	0.049	0.6	0.099	0.9		20.0
22.5		0.0054	0.2	0.0077	0.2	0.0128	0.3	0.026	0.4	0.052	0.6	0.106	0.9		22.5
25.0		0.0058	0.2	0.0082	0.2	0.0136	0.3	0.027	0.4	0.055	0.6	0.113	0.9		25.0
27.5		0.0061	0.2	0.0087	0.2	0.0144	0.3	0.029	0.4	0.058	0.6	0.119	0.9		27.5
30.0		0.0064	0.2	0.0091	0.2	0.0151	0.3	0.031	0.4	0.061	0.7	0.125	1.0		30.0
32.5		0.0067	0.2	0.0096	0.2	0.0159	0.3	0.032	0.5	0.064	0.7	0.131	1.0		32.5
35.0		0.0070	0.2	0.0100	0.2	0.0166	0.3	0.033	0.5	0.067	0.7	0.137	1.0		35.0
37.5		0.0073	0.2	0.0104	0.2	0.0172	0.3	0.035	0.5	0.070	0.7	0.142	1.0		37.5
40.0		0.0076	0.2	0.0108	0.2	0.0179	0.3	0.036	0.5	0.072	0.7	0.148	1.0		40.0
42.5		0.0079	0.2	0.0112	0.2	0.0185	0.3	0.037	0.5	0.075	0.7	0.153	1.0	0.3	42.5
45.0		0.0081	0.2	0.0116	0.2	0.0192	0.3	0.039	0.5	0.077	0.7	0.158	1.0		45.0
47.5		0.0084	0.2	0.0120	0.3	0.0198	0.3	0.040	0.5	0.080	0.7	0.163	1.0		47.5
50.0		0.0087	0.2	0.0123	0.3	0.0204	0.3	0.041	0.5	0.082	0.7	0.168	1.0		50.0
52.5	0.15	0.0089	0.2	0.0127	0.3	0.0210	0.3	0.042	0.5	0.085	0.7	0.172	1.0		52.5
55.0		0.0092	0.2	0.0130	0.3	0.0215	0.3	0.043	0.5	0.087	0.7	0.177	1.0		55.0
57.5		0.0094	0.2	0.0134	0.3	0.0221	0.3	0.045	0.5	0.089	0.7	0.182	1.0		57.5
60.0		0.0096	0.2	0.0137	0.3	0.0227	0.3	0.046	0.5	0.091	0.7	0.186	1.0		60.0
62.5		0.0099	0.2	0.0141	0.3	0.0232	0.3	0.047	0.5	0.094	0.7	0.190	1.1		62.5
65.0		0.0101	0.2	0.0144	0.3	0.0237	0.3	0.048	0.5	0.096	0.7	0.195	1.1		65.0
67.5		0.0103	0.2	0.0147	0.3	0.0243	0.3	0.049	0.5	0.098	0.7	0.199	1.1		67.5
70.0		0.0106	0.2	0.0150	0.3	0.0248	0.4	0.050	0.5	0.100	0.7	0.203	1.1		70.0
72.5		0.0108	0.2	0.0153	0.3	0.0253	0.4	0.051	0.5	0.102	0.7	0.207	1.1		72.5
75.0		0.0110	0.2	0.0156	0.3	0.0258	0.4	0.052	0.5	0.104	0.7	0.211	1.1		75.0
77.5		0.0112	0.2	0.0159	0.3	0.0263	0.4	0.053	0.5	0.106	0.7	0.215	1.1		77.5

M = mass flow rate **kg/s** l_e = equivalent length of pipe **m** Δp_l = pressure loss per unit length **Pa/m** v = velocity **m/s**

Flow of water at 75 deg C

Δp_l	v	12 mm		14 mm		16 mm		20 mm		25 mm		32 mm		v	Δp_l
		M	l_e	M	l_e	M	l_e	M	l_e	M	l_e	M	l_e		
80.0		0.0114	0.2	0.0162	0.3	0.0266	0.4	0.054	0.5	0.108	0.8	0.219	1.1		80.0
82.5		0.0116	0.2	0.0165	0.3	0.0273	0.4	0.055	0.5	0.110	0.8	0.223	1.1		82.5
85.0		0.0118	0.2	0.0168	0.3	0.0277	0.4	0.056	0.5	0.111	0.8	0.227	1.1		85.0
87.5		0.0120	0.2	0.0171	0.3	0.0282	0.4	0.057	0.5	0.113	0.8	0.230	1.1		87.5
90.0		0.0122	0.2	0.0174	0.3	0.0287	0.4	0.058	0.5	0.115	0.8	0.234	1.1		90.0
92.5		0.0124	0.2	0.018	0.3	0.029	0.4	0.059	0.5	0.117	0.8	0.238	1.1		92.5
95.0		0.0126	0.2	0.018	0.3	0.030	0.4	0.059	0.5	0.119	0.8	0.241	1.1		95.0
97.5		0.0128	0.2	0.018	0.3	0.030	0.4	0.060	0.5	0.121	0.8	0.245	1.1		97.5
100.0		0.0130	0.2	0.018	0.3	0.030	0.4	0.061	0.5	0.122	0.8	0.248	1.1	0.5	100.0
120.0		0.014	0.2	0.021	0.3	0.034	0.4	0.068	0.6	0.136	0.8	0.275	1.1		120.0
140.0		0.016	0.2	0.022	0.3	0.037	0.4	0.074	0.6	0.148	0.8	0.301	1.2		140.0
160.0		0.017	0.3	0.024	0.3	0.040	0.4	0.080	0.6	0.160	0.8	0.324	1.2		160.0
180.0	0.3	0.018	0.3	0.026	0.3	0.043	0.4	0.086	0.6	0.171	0.8	0.346	1.2		180.0
200.0		0.019	0.3	0.028	0.3	0.045	0.4	0.091	0.6	0.181	0.9	0.367	1.2		200.0
220.0		0.021	0.3	0.029	0.3	0.048	0.4	0.096	0.6	0.191	0.9	0.388	1.2		220.0
240.0		0.022	0.3	0.031	0.3	0.050	0.4	0.101	0.6	0.201	0.9	0.407	1.3		240.0
260.0		0.023	0.3	0.032	0.3	0.053	0.4	0.106	0.6	0.210	0.9	0.426	1.3		260.0
280.0		0.024	0.3	0.034	0.3	0.055	0.4	0.110	0.6	0.219	0.9	0.444	1.3		280.0
300.0		0.025	0.3	0.035	0.3	0.057	0.4	0.115	0.6	0.228	0.9	0.461	1.3		300.0
320.0		0.026	0.3	0.036	0.3	0.059	0.4	0.119	0.6	0.236	0.9	0.478	1.3		320.0
340.0		0.026	0.3	0.037	0.3	0.061	0.4	0.123	0.6	0.244	0.9	0.495	1.3		340.0
360.0		0.027	0.3	0.039	0.3	0.064	0.4	0.127	0.6	0.252	0.9	0.511	1.3	1.0	360.0
380.0		0.028	0.3	0.040	0.3	0.066	0.5	0.131	0.6	0.260	0.9	0.527	1.3		380.0
400.0		0.029	0.3	0.041	0.4	0.067	0.5	0.135	0.7	0.268	0.9	0.542	1.3		400.0
420.0	0.5	0.030	0.3	0.042	0.4	0.069	0.5	0.139	0.7	0.275	0.9	0.557	1.3		420.0
440.0		0.031	0.3	0.043	0.4	0.071	0.5	0.142	0.7	0.283	0.9	0.572	1.4		440.0
460.0		0.031	0.3	0.045	0.4	0.073	0.5	0.146	0.7	0.290	0.9	0.586	1.4		460.0
480.0		0.032	0.3	0.046	0.4	0.075	0.5	0.149	0.7	0.297	1.0	0.600	1.4		480.0
500.0		0.033	0.3	0.047	0.4	0.077	0.5	0.153	0.7	0.304	1.0	0.614	1.4		500.0
520.0		0.034	0.3	0.048	0.4	0.078	0.5	0.156	0.7	0.311	1.0	0.628	1.4		520.0
540.0		0.034	0.3	0.049	0.4	0.080	0.5	0.160	0.7	0.317	1.0	0.641	1.4		540.0
560.0		0.035	0.3	0.050	0.4	0.082	0.5	0.163	0.7	0.324	1.0	0.654	1.4		560.0
580.0		0.036	0.3	0.051	0.4	0.083	0.5	0.166	0.7	0.330	1.0	0.667	1.4		580.0
600.0		0.037	0.3	0.052	0.4	0.085	0.5	0.170	0.7	0.336	1.0	0.680	1.4		600.0
620.0		0.037	0.3	0.053	0.4	0.087	0.5	0.173	0.7	0.343	1.0	0.692	1.4		620.0
640.0		0.038	0.3	0.054	0.4	0.088	0.5	0.176	0.7	0.349	1.0	0.705	1.4		640.0
660.0		0.039	0.3	0.055	0.4	0.090	0.5	0.179	0.7	0.355	1.0	0.717	1.4		660.0
680.0		0.039	0.3	0.056	0.4	0.091	0.5	0.182	0.7	0.361	1.0	0.729	1.4		680.0
700.0		0.040	0.3	0.057	0.4	0.093	0.5	0.185	0.7	0.367	1.0	0.741	1.4		700.0
720.0		0.041	0.3	0.058	0.4	0.094	0.5	0.188	0.7	0.373	1.0	0.753	1.4		720.0
740.0		0.041	0.3	0.058	0.4	0.096	0.5	0.191	0.7	0.378	1.0	0.764	1.4		740.0
760.0		0.042	0.3	0.059	0.4	0.097	0.5	0.194	0.7	0.384	1.0	0.776	1.4	1.5	760.0
780.0		0.043	0.3	0.060	0.4	0.099	0.5	0.197	0.7	0.390	1.0	0.787	1.4		780.0
800.0		0.043	0.3	0.061	0.4	0.100	0.5	0.199	0.7	0.395	1.0	0.798	1.4		800.0
820.0		0.044	0.3	0.062	0.4	0.101	0.5	0.202	0.7	0.401	1.0	0.809	1.5		820.0
840.0		0.044	0.3	0.063	0.4	0.103	0.5	0.205	0.7	0.406	1.0	0.820	1.5		840.0
860.0		0.045	0.3	0.064	0.4	0.104	0.5	0.208	0.7	0.412	1.0	0.831	1.5		860.0
880.0		0.046	0.3	0.064	0.4	0.106	0.5	0.210	0.7	0.417	1.0	0.842	1.5		880.0
900.0		0.046	0.3	0.065	0.4	0.107	0.5	0.213	0.7	0.422	1.0	0.852	1.5		900.0
920.0		0.047	0.3	0.066	0.4	0.108	0.5	0.216	0.7	0.427	1.0	0.863	1.5		920.0
940.0		0.047	0.3	0.067	0.4	0.110	0.5	0.218	0.7	0.433	1.0	0.873	1.5		940.0
960.0		0.048	0.3	0.068	0.4	0.111	0.5	0.221	0.7	0.438	1.0	0.883	1.5		960.0
980.0		0.048	0.3	0.069	0.4	0.112	0.5	0.223	0.7	0.443	1.0	0.893	1.5		980.0
1000.0		0.049	0.3	0.069	0.4	0.113	0.5	0.226	0.7	0.448	1.0	0.904	1.5		1000.0
1100.0		0.052	0.3	0.073	0.4	0.120	0.5	0.238	0.7	0.472	1.1	0.953	1.5		1100.0
1200.0		0.054	0.3	0.077	0.4	0.126	0.5	0.250	0.8	0.496	1.1	1.000	1.5	2.0	1200.0
1300.0		0.057	0.3	0.080	0.4	0.132	0.5	0.262	0.8	0.519	1.1	1.045	1.5		1300.0
1400.0	1.0	0.059	0.3	0.084	0.4	0.137	0.5	0.273	0.8	0.540	1.1	1.089	1.5		1400.0
1500.0		0.062	0.4	0.087	0.4	0.143	0.5	0.284	0.8	0.562	1.1	1.132	1.6		1500.0
1600.0		0.064	0.4	0.090	0.4	0.148	0.5	0.294	0.8	0.582	1.1	1.173	1.6		1600.0

M = mass flow rate **kg/s** **l_e** = equivalent length of pipe **m** **Δp_l** = pressure loss per unit length **Pa/m** **v** = velocity **m/s**

Flow of water at 75 deg C

Δp_l	v	12 mm		14 mm		16 mm		20 mm		25 mm		32 mm		v	Δp_l
		M	l_e	M	l_e	M	l_e	M	l_e	M	l_e	M	l_e		
1600.0		0.064	0.4	0.090	0.4	0.148	0.5	0.294	0.8	0.582	1.1	1.173	1.6		1700.0
1700.0		0.066	0.4	0.094	0.4	0.153	0.6	0.304	0.8	0.602	1.1	1.213	1.6		1800.0
1800.0		0.068	0.4	0.097	0.4	0.158	0.6	0.314	0.8	0.622	1.1	1.252	1.6		1900.0
1900.0		0.071	0.4	0.100	0.4	0.163	0.6	0.324	0.8	0.641	1.1	1.290	1.6	2.5	2000.0
2000.0		0.073	0.4	0.103	0.4	0.168	0.6	0.333	0.8	0.659	1.1	1.327	1.6		2100.0
2100.0		0.075	0.4	0.105	0.4	0.172	0.6	0.342	0.8	0.677	1.1	1.364	1.6		2100.0
2200.0		0.077	0.4	0.108	0.4	0.177	0.6	0.351	0.8	0.695	1.1	1.399	1.6		2200.0
2300.0		0.079	0.4	0.111	0.4	0.181	0.6	0.360	0.8	0.712	1.1	1.434	1.6		2300.0
2400.0		0.081	0.4	0.114	0.4	0.186	0.6	0.369	0.8	0.729	1.2	1.468	1.6		2400.0
2500.0		0.082	0.4	0.116	0.5	0.190	0.6	0.377	0.8	0.746	1.2	1.501	1.6		2500.0
2600.0		0.084	0.4	0.119	0.5	0.194	0.6	0.386	0.8	0.763	1.2	1.534	1.6	3.0	2600.0
2700.0		0.086	0.4	0.122	0.5	0.198	0.6	0.394	0.8	0.779	1.2	1.567	1.7		2700.0
2800.0	1.5	0.088	0.4	0.124	0.5	0.203	0.6	0.402	0.8	0.795	1.2	1.598	1.7		2800.0
2900.0		0.090	0.4	0.127	0.5	0.207	0.6	0.410	0.8	0.810	1.2	1.630	1.7		2900.0
3000.0		0.091	0.4	0.129	0.5	0.210	0.6	0.418	0.8	0.826	1.2	1.661	1.7		3000.0
3100.0		0.093	0.4	0.131	0.5	0.214	0.6	0.426	0.8	0.841	1.2	1.691	1.7		3100.0
3200.0		0.095	0.4	0.134	0.5	0.218	0.6	0.433	0.8	0.856	1.2	1.721	1.7		3200.0
3300.0		0.096	0.4	0.136	0.5	0.222	0.6	0.441	0.8	0.870	1.2	1.750	1.7		3300.0
3400.0		0.098	0.4	0.138	0.5	0.226	0.6	0.448	0.8	0.885	1.2	1.779	1.7		3400.0
3500.0		0.100	0.4	0.141	0.5	0.229	0.6	0.455	0.9	0.899	1.2	1.808	1.7		3500.0
3600.0		0.101	0.4	0.143	0.5	0.233	0.6	0.462	0.9	0.913	1.2	1.836	1.7		3600.0
3700.0		0.103	0.4	0.145	0.5	0.237	0.6	0.470	0.9	0.927	1.2	1.864	1.7		3700.0
3800.0		0.104	0.4	0.147	0.5	0.240	0.6	0.477	0.9	0.941	1.2	1.892	1.7		3800.0
3900.0		0.106	0.4	0.149	0.5	0.244	0.6	0.484	0.9	0.955	1.2	1.919	1.7		3900.0
4000.0		0.107	0.4	0.152	0.5	0.247	0.6	0.490	0.9	0.968	1.2	1.946	1.7		4000.0
4100.0		0.109	0.4	0.154	0.5	0.251	0.6	0.497	0.9	0.981	1.2	1.973	1.7		4100.0
4200.0		0.110	0.4	0.156	0.5	0.254	0.6	0.504	0.9	0.995	1.2	1.999	1.7		4200.0
4300.0		0.112	0.4	0.158	0.5	0.257	0.6	0.511	0.9	1.008	1.2	2.025	1.7		4300.0
4400.0		0.113	0.4	0.160	0.5	0.261	0.6	0.517	0.9	1.021	1.2	2.051	1.7		4400.0
4500.0		0.115	0.4	0.162	0.5	0.264	0.6	0.524	0.9	1.033	1.2	2.076	1.7		4500.0
4600.0		0.116	0.4	0.164	0.5	0.267	0.6	0.530	0.9	1.046	1.2	2.102	1.7		4600.0
4700.0		0.118	0.4	0.166	0.5	0.271	0.6	0.536	0.9	1.058	1.2	2.127	1.7		4700.0
4800.0	2.0	0.119	0.4	0.168	0.5	0.274	0.6	0.543	0.9	1.071	1.2	2.151	1.8		4800.0
4900.0		0.120	0.4	0.170	0.5	0.277	0.6	0.549	0.9	1.083	1.2	2.176	1.8		4900.0
5000.0		0.122	0.4	0.172	0.5	0.280	0.6	0.555	0.9	1.095	1.2	2.200	1.8		5000.0
5100.0		0.123	0.4	0.174	0.5	0.283	0.6	0.561	0.9	1.107	1.2	2.224	1.8		5100.0
5200.0		0.125	0.4	0.176	0.5	0.286	0.6	0.567	0.9	1.119	1.3	2.248	1.8		5200.0
5300.0		0.126	0.4	0.177	0.5	0.289	0.6	0.573	0.9	1.131	1.3	2.272	1.8		5300.0
5400.0		0.127	0.4	0.179	0.5	0.292	0.6	0.579	0.9	1.143	1.3	2.295	1.8		5400.0
5500.0		0.129	0.4	0.181	0.5	0.295	0.6	0.585	0.9	1.154	1.3	2.319	1.8		5500.0
5600.0		0.130	0.4	0.183	0.5	0.298	0.6	0.591	0.9	1.166	1.3	2.342	1.8		5600.0
5700.0		0.131	0.4	0.185	0.5	0.301	0.6	0.597	0.9	1.177	1.3	2.364	1.8		5700.0
5800.0		0.132	0.4	0.187	0.5	0.304	0.6	0.603	0.9	1.189	1.3	2.387	1.8		5800.0
5900.0		0.134	0.4	0.188	0.5	0.307	0.6	0.608	0.9	1.200	1.3	2.410	1.8		5900.0
6000.0		0.135	0.4	0.190	0.5	0.310	0.6	0.614	0.9	1.211	1.3	2.432	1.8		6000.0
6100.0		0.136	0.4	0.192	0.5	0.313	0.6	0.620	0.9	1.222	1.3	2.454	1.8		6100.0
6200.0		0.137	0.4	0.194	0.5	0.316	0.6	0.625	0.9	1.233	1.3	2.476	1.8		6200.0
6300.0		0.139	0.4	0.195	0.5	0.319	0.6	0.631	0.9	1.244	1.3	2.498	1.8		6300.0
6400.0		0.140	0.4	0.197	0.5	0.321	0.6	0.637	0.9	1.255	1.3	2.520	1.8		6400.0
6500.0		0.141	0.4	0.199	0.5	0.324	0.6	0.642	0.9	1.266	1.3	2.541	1.8		6500.0
6600.0		0.142	0.4	0.201	0.5	0.327	0.6	0.647	0.9	1.277	1.3	2.563	1.8		6600.0
6700.0		0.144	0.4	0.202	0.5	0.330	0.6	0.653	0.9	1.287	1.3	2.584	1.8		6700.0
6800.0		0.145	0.4	0.204	0.5	0.332	0.7	0.658	0.9	1.298	1.3	2.605	1.8		6800.0
6900.0		0.146	0.4	0.206	0.5	0.335	0.7	0.664	0.9	1.308	1.3	2.626	1.8		6900.0
7000.0		0.147	0.4	0.207	0.5	0.338	0.7	0.669	0.9	1.319	1.3	2.647	1.8		7000.0
7100.0	2.5	0.148	0.4	0.209	0.5	0.340	0.7	0.674	0.9	1.329	1.3	2.667	1.8		7100.0
7200.0		0.149	0.4	0.211	0.5	0.343	0.7	0.679	0.9	1.339	1.3	2.688	1.8		7200.0
7300.0		0.151	0.4	0.212	0.5	0.346	0.7	0.685	0.9	1.349	1.3	2.708	1.8		7300.0
7400.0		0.152	0.4	0.214	0.5	0.348	0.7	0.690	0.9	1.360	1.3	2.729	1.8		7400.0
7500.0		0.153	0.4	0.215	0.5	0.351	0.7	0.695	0.9	1.370	1.3	2.749	1.8		7500.0

M = mass flow rate **kg/s** **l_e** = equivalent length of pipe **m** **Δp_l** = pressure loss per unit length **Pa/m** **v** = velocity **m/s**

Flow of water at 75 deg C

Δp_l	v	40 mm		50 mm		63 mm		75 mm		90 mm		110 mm		v	Δp_l
		M	l_e	M	l_e	M	l_e	M	l_e	M	l_e	M	l_e		
0.1		0.008	0.5	0.016	0.7	0.029	1.0	0.045	1.3	0.078	1.8	0.139	2.4		0.1
0.2		0.012	0.6	0.024	0.8	0.043	1.2	0.068	1.5	0.117	2.0	0.207	2.7		0.2
0.3		0.015	0.6	0.030	0.9	0.055	1.2	0.086	1.6	0.148	2.1	0.262	2.9		0.3
0.4		0.018	0.6	0.036	0.9	0.065	1.3	0.102	1.7	0.175	2.2	0.309	3.0	0.05	0.4
0.5		0.020	0.7	0.041	1.0	0.074	1.4	0.116	1.7	0.199	2.3	0.351	3.1		0.5
0.6		0.023	0.7	0.045	1.0	0.083	1.4	0.129	1.8	0.221	2.4	0.390	3.2		0.6
0.7		0.025	0.7	0.050	1.0	0.090	1.4	0.141	1.8	0.241	2.4	0.426	3.3		0.7
0.8		0.027	0.7	0.054	1.1	0.098	1.5	0.152	1.9	0.260	2.5	0.460	3.3		0.8
0.9		0.029	0.7	0.057	1.1	0.105	1.5	0.163	1.9	0.278	2.5	0.492	3.4		0.9
1.0		0.031	0.8	0.061	1.1	0.111	1.5	0.173	1.9	0.296	2.6	0.522	3.5		1.0
1.5	0.05	0.039	0.8	0.077	1.2	0.141	1.6	0.219	2.0	0.373	2.7	0.658	3.7		1.5
2.0		0.046	0.8	0.091	1.2	0.166	1.7	0.258	2.1	0.440	2.8	0.774	3.8		2.0
2.5		0.053	0.9	0.104	1.3	0.189	1.7	0.293	2.2	0.499	2.9	0.879	3.9	0.15	2.5
3.0		0.059	0.9	0.116	1.3	0.209	1.8	0.326	2.3	0.554	3.0	0.974	4.0		3.0
3.5		0.064	0.9	0.126	1.3	0.229	1.8	0.355	2.3	0.604	3.1	1.063	4.1		3.5
4.0		0.069	1.0	0.136	1.4	0.247	1.9	0.383	2.4	0.652	3.1	1.146	4.2		4.0
4.5		0.074	1.0	0.146	1.4	0.264	1.9	0.410	2.4	0.697	3.2	1.224	4.2		4.5
5.0		0.079	1.0	0.155	1.4	0.280	1.9	0.435	2.4	0.739	3.2	1.299	4.3		5.0
5.5		0.083	1.0	0.164	1.4	0.296	2.0	0.460	2.5	0.780	3.2	1.371	4.3		5.5
6.0		0.088	1.0	0.172	1.5	0.311	2.0	0.483	2.5	0.820	3.3	1.439	4.4		6.0
6.5		0.092	1.0	0.180	1.5	0.326	2.0	0.505	2.5	0.857	3.3	1.506	4.4		6.5
7.0		0.096	1.0	0.188	1.5	0.340	2.0	0.527	2.5	0.894	3.3	1.570	4.5		7.0
7.5		0.100	1.0	0.195	1.5	0.353	2.0	0.548	2.6	0.930	3.4	1.632	4.5		7.5
8.0		0.103	1.1	0.203	1.5	0.366	2.1	0.568	2.6	0.964	3.4	1.692	4.5		8.0
8.5		0.107	1.1	0.210	1.5	0.379	2.1	0.588	2.6	0.997	3.4	1.750	4.6		8.5
9.0		0.111	1.1	0.217	1.5	0.392	2.1	0.607	2.6	1.030	3.4	1.807	4.6		9.0
9.5		0.114	1.1	0.224	1.5	0.404	2.1	0.626	2.6	1.062	3.5	1.863	4.6	0.3	9.5
10.0	0.15	0.117	1.1	0.230	1.6	0.416	2.1	0.645	2.7	1.093	3.5	1.917	4.7		10.0
12.5		0.134	1.1	0.262	1.6	0.472	2.2	0.731	2.7	1.239	3.6	2.172	4.8		12.5
15.0		0.148	1.2	0.290	1.7	0.523	2.2	0.810	2.8	1.373	3.7	2.405	4.9		15.0
17.5		0.162	1.2	0.317	1.7	0.571	2.3	0.884	2.9	1.496	3.7	2.621	5.0		17.5
20.0		0.175	1.2	0.342	1.7	0.615	2.3	0.953	2.9	1.613	3.8	2.824	5.1		20.0
22.5		0.187	1.2	0.365	1.7	0.658	2.4	1.018	3.0	1.722	3.9	3.016	5.1	0.5	22.5
25.0		0.198	1.2	0.388	1.8	0.698	2.4	1.080	3.0	1.827	3.9	3.198	5.2		25.0
27.5		0.209	1.3	0.409	1.8	0.736	2.4	1.139	3.0	1.927	4.0	3.372	5.2		27.5
30.0		0.220	1.3	0.430	1.8	0.773	2.4	1.196	3.1	2.023	4.0	3.540	5.3		30.0
32.5	0.3	0.230	1.3	0.450	1.8	0.809	2.5	1.251	3.1	2.115	4.0	3.701	5.3		32.5
35.0		0.240	1.3	0.469	1.8	0.843	2.5	1.304	3.1	2.205	4.1	3.856	5.4		35.0
37.5		0.250	1.3	0.487	1.9	0.877	2.5	1.355	3.1	2.291	4.1	4.007	5.4		37.5
40.0		0.259	1.3	0.505	1.9	0.909	2.5	1.405	3.2	2.375	4.1	4.153	5.5		40.0
42.5		0.268	1.3	0.523	1.9	0.940	2.6	1.454	3.2	2.457	4.2	4.295	5.5		42.5
45.0		0.277	1.4	0.540	1.9	0.971	2.6	1.501	3.2	2.536	4.2	4.434	5.5		45.0
47.5		0.286	1.4	0.557	1.9	1.001	2.6	1.547	3.2	2.613	4.2	4.569	5.6		47.5
50.0		0.294	1.4	0.573	1.9	1.030	2.6	1.592	3.2	2.689	4.2	4.701	5.6		50.0
52.5		0.302	1.4	0.589	1.9	1.058	2.6	1.636	3.3	2.763	4.3	4.829	5.6		52.5
55.0		0.310	1.4	0.605	2.0	1.086	2.6	1.679	3.3	2.836	4.3	4.956	5.7		55.0
57.5		0.318	1.4	0.620	2.0	1.114	2.6	1.721	3.3	2.907	4.3	5.079	5.7		57.5
60.0		0.326	1.4	0.635	2.0	1.141	2.7	1.762	3.3	2.976	4.3	5.200	5.7		60.0
62.5		0.334	1.4	0.650	2.0	1.167	2.7	1.803	3.3	3.044	4.3	5.319	5.7		62.5
65.0		0.341	1.4	0.664	2.0	1.193	2.7	1.843	3.3	3.112	4.4	5.436	5.8		65.0
67.5		0.348	1.4	0.678	2.0	1.218	2.7	1.882	3.4	3.177	4.4	5.551	5.8		67.5
70.0		0.356	1.4	0.692	2.0	1.243	2.7	1.921	3.4	3.242	4.4	5.664	5.8		70.0
72.5		0.363	1.4	0.706	2.0	1.268	2.7	1.959	3.4	3.306	4.4	5.775	5.8		72.5
75.0		0.370	1.4	0.720	2.0	1.292	2.7	1.996	3.4	3.369	4.4	5.884	5.8		75.0
77.5		0.377	1.4	0.733	2.0	1.316	2.7	2.033	3.4	3.431	4.4	5.992	5.9		77.5

M = mass flow rate **kg/s** **l_e** = equivalent length of pipe **m** **Δp_l** = pressure loss per unit length **Pa/m** **v** = velocity **m/s**

Flow of water at 75 deg C

Δp_l	v	40 mm		50 mm		63 mm		75 mm		90 mm		110 mm		v	Δp_l
		M	l_e	M	l_e	M	l_e	M	l_e	M	l_e	M	l_e		
80.0	0.5	0.383	1.5	0.746	2.0	1.34	2.8	2.07	3.4	3.49	4.5	6.10	5.9	1.0	80.0
82.5		0.390	1.5	0.759	2.1	1.36	2.8	2.10	3.4	3.55	4.5	6.20	5.9		82.5
85.0		0.397	1.5	0.772	2.1	1.39	2.8	2.14	3.5	3.61	4.5	6.31	5.9		85.0
87.5		0.403	1.5	0.785	2.1	1.41	2.8	2.17	3.5	3.67	4.5	6.41	5.9		87.5
90.0		0.410	1.5	0.797	2.1	1.43	2.8	2.21	3.5	3.73	4.5	6.51	6.0		90.0
92.5		0.416	1.5	0.810	2.1	1.45	2.8	2.24	3.5	3.78	4.5	6.61	6.0		92.5
95.0		0.422	1.5	0.822	2.1	1.47	2.8	2.28	3.5	3.84	4.5	6.71	6.0		95.0
97.5		0.429	1.5	0.834	2.1	1.50	2.8	2.31	3.5	3.90	4.6	6.80	6.0		97.5
100.0		0.435	1.5	0.846	2.1	1.52	2.8	2.34	3.5	3.95	4.6	6.90	6.0		100.0
120.0		0.482	1.5	0.937	2.1	1.68	2.9	2.59	3.6	4.37	4.7	7.63	6.1		120.0
140.0		0.525	1.6	1.021	2.2	1.83	2.9	2.82	3.7	4.76	4.7	8.31	6.2		140.0
160.0		0.566	1.6	1.100	2.2	1.97	3.0	3.04	3.7	5.13	4.8	8.94	6.3		160.0
180.0	0.605	1.6	1.175	2.3	2.10	3.0	3.25	3.8	5.47	4.9	9.54	6.4	180.0		
200.0	0.642	1.6	1.246	2.3	2.23	3.1	3.44	3.8	5.80	4.9	10.11	6.5	200.0		
220.0	0.677	1.6	1.314	2.3	2.35	3.1	3.63	3.8	6.11	5.0	10.65	6.5	220.0		
240.0	0.710	1.7	1.379	2.3	2.47	3.1	3.81	3.9	6.41	5.0	11.17	6.6	240.0		
260.0	0.743	1.7	1.442	2.4	2.58	3.1	3.98	3.9	6.70	5.1	11.68	6.6	260.0		
280.0	0.774	1.7	1.502	2.4	2.69	3.2	4.14	3.9	6.98	5.1	12.16	6.7	280.0		
300.0	0.805	1.7	1.561	2.4	2.79	3.2	4.31	4.0	7.25	5.1	12.63	6.7	300.0		
320.0	0.834	1.7	1.618	2.4	2.90	3.2	4.46	4.0	7.51	5.2	13.09	6.8	320.0		
340.0	0.863	1.7	1.674	2.4	2.99	3.2	4.61	4.0	7.77	5.2	13.53	6.8	340.0		
360.0	0.891	1.7	1.728	2.4	3.09	3.3	4.76	4.0	8.01	5.2	13.96	6.9	360.0		
380.0	0.918	1.8	1.780	2.5	3.18	3.3	4.91	4.1	8.26	5.2	14.38	6.9	380.0		
400.0	0.945	1.8	1.832	2.5	3.28	3.3	5.05	4.1	8.49	5.3	14.79	6.9	400.0		
420.0	0.971	1.8	1.882	2.5	3.37	3.3	5.18	4.1	8.72	5.3	15.19	7.0	420.0		
440.0	0.997	1.8	1.931	2.5	3.45	3.3	5.32	4.1	8.95	5.3	15.58	7.0	440.0		
460.0	1.021	1.8	1.979	2.5	3.54	3.3	5.45	4.1	9.17	5.3	15.97	7.0	460.0		
480.0	1.046	1.8	2.027	2.5	3.62	3.4	5.58	4.2	9.39	5.4	16.34	7.0	480.0		
500.0	1.070	1.8	2.073	2.5	3.71	3.4	5.71	4.2	9.60	5.4	16.71	7.1	500.0		
520.0	1.094	1.8	2.118	2.5	3.79	3.4	5.83	4.2	9.81	5.4	17.07	7.1	520.0		
540.0	1.117	1.8	2.163	2.5	3.87	3.4	5.95	4.2	10.01	5.4	17.43	7.1	540.0		
560.0	1.140	1.8	2.207	2.6	3.94	3.4	6.07	4.2	10.22	5.5	17.78	7.1	560.0		
580.0	1.162	1.8	2.251	2.6	4.02	3.4	6.19	4.2	10.42	5.5	18.13	7.2	580.0		
600.0	1.184	1.9	2.293	2.6	4.10	3.4	6.31	4.3	10.61	5.5	18.46	7.2	600.0		
620.0	1.206	1.9	2.335	2.6	4.17	3.4	6.42	4.3	10.80	5.5	18.80	7.2	620.0		
640.0	1.227	1.9	2.377	2.6	4.25	3.5	6.54	4.3	10.99	5.5	19.13	7.2	640.0		
660.0	1.249	1.9	2.417	2.6	4.32	3.5	6.65	4.3	11.18	5.5	19.45	7.3	660.0		
680.0	1.270	1.9	2.458	2.6	4.39	3.5	6.76	4.3	11.36	5.6	19.77	7.3	680.0		
700.0	1.290	1.9	2.497	2.6	4.46	3.5	6.87	4.3	11.55	5.6	20.09	7.3	700.0		
720.0	1.310	1.9	2.536	2.6	4.53	3.5	6.97	4.3	11.73	5.6	20.40	7.3	720.0		
740.0	1.331	1.9	2.575	2.6	4.60	3.5	7.08	4.3	11.90	5.6	20.71	7.3	740.0		
760.0	1.350	1.9	2.613	2.6	4.67	3.5	7.18	4.4	12.08	5.6	21.01	7.4	760.0		
780.0	1.370	1.9	2.651	2.6	4.74	3.5	7.29	4.4	12.25	5.6	21.31	7.4	780.0		
800.0	1.389	1.9	2.689	2.7	4.80	3.5	7.39	4.4	12.42	5.6	21.61	7.4	800.0		
820.0	1.409	1.9	2.725	2.7	4.87	3.5	7.49	4.4	12.59	5.7	21.90	7.4	820.0		
840.0	1.427	1.9	2.762	2.7	4.93	3.6	7.59	4.4	12.76	5.7	22.19	7.4	840.0		
860.0	1.446	1.9	2.798	2.7	5.00	3.6	7.69	4.4	12.92	5.7	22.48	7.4	860.0		
880.0	1.465	1.9	2.834	2.7	5.06	3.6	7.79	4.4	13.09	5.7	22.76	7.5	880.0		
900.0	1.483	1.9	2.869	2.7	5.12	3.6	7.88	4.4	13.25	5.7	23.04	7.5	900.0		
920.0	1.501	1.9	2.904	2.7	5.19	3.6	7.98	4.4	13.41	5.7	23.32	7.5	920.0		
940.0	1.519	1.9	2.939	2.7	5.25	3.6	8.07	4.4	13.57	5.7	23.60	7.5	940.0		
960.0	1.537	2.0	2.973	2.7	5.31	3.6	8.17	4.5	13.73	5.7	23.87	7.5	960.0		
980.0	1.555	2.0	3.007	2.7	5.37	3.6	8.26	4.5	13.88	5.8	24.14	7.5	980.0		
1000.0	1.572	2.0	3.041	2.7	5.43	3.6	8.35	4.5	14.04	5.8	24.41	7.5	1000.0		
1100.0	1.658	2.0	3.205	2.7	5.72	3.7	8.80	4.5	14.79	5.8	25.71	7.6	1100.0		
1200.0	1.739	2.0	3.363	2.8	6.00	3.7	9.23	4.6	15.51	5.9	26.95	7.7	1200.0		
1300.0	1.818	2.0	3.514	2.8	6.27	3.7	9.64	4.6	16.20	5.9	28.16	7.7	1300.0		
1400.0	1.894	2.0	3.660	2.8	6.53	3.7	10.04	4.6	16.87	5.9	29.31	7.8	1400.0		
1500.0	1.968	2.0	3.802	2.8	6.78	3.8	10.43	4.6	17.52	6.0	30.44	7.8	1500.0		
1600.0	2.039	2.1	3.940	2.9	7.03	3.8	10.80	4.7	18.14	6.0	31.52	7.9	1600.0		

M = mass flow rate **kg/s** **l_e** = equivalent length of pipe **m** **Δp_l** = pressure loss per unit length **Pa/m** **v** = velocity **m/s**

Flow of water at 75 deg C

Δp_l	v	40 mm		50 mm		63 mm		75 mm		90 mm		110 mm		v	Δp_l
		M	l_e	M	l_e	M	l_e	M	l_e	M	l_e	M	l_e		
1600.0	3.0	2.04	2.1	3.94	2.9	7.03	3.8	10.80	4.7	18.14	6.0	31.52	7.9	1700.0	
1700.0		2.11	2.1	4.07	2.9	7.26	3.8	11.17	4.7	18.75	6.1	32.58	7.9	1800.0	
1800.0		2.18	2.1	4.20	2.9	7.50	3.8	11.52	4.7	19.35	6.1	33.61	7.9	1900.0	
1900.0		2.24	2.1	4.33	2.9	7.72	3.9	11.87	4.8	19.92	6.1	34.61	8.0	2000.0	
2000.0		2.31	2.1	4.45	2.9	7.94	3.9	12.21	4.8	20.49	6.1	35.59	8.0	2100.0	
2100.0		2.37	2.1	4.57	2.9	8.16	3.9	12.54	4.8	21.04	6.2	36.54	8.1	2100.0	
2200.0		2.43	2.1	4.69	2.9	8.37	3.9	12.86	4.8	21.58	6.2	37.48	8.1	2200.0	
2300.0		2.49	2.1	4.81	3.0	8.57	3.9	13.17	4.8	22.11	6.2	38.39	8.1	2300.0	
2400.0		2.55	2.1	4.92	3.0	8.77	3.9	13.48	4.9	22.63	6.2	39.29	8.1	2400.0	
2500.0		2.61	2.2	5.03	3.0	8.97	4.0	13.79	4.9	23.14	6.3	40.17	8.2	2500.0	
2600.0		2.66	2.2	5.14	3.0	9.17	4.0	14.08	4.9	23.63	6.3	41.03	8.2	2600.0	
2700.0		2.72	2.2	5.25	3.0	9.36	4.0	14.38	4.9	24.12	6.3	41.88	8.2	2700.0	
2800.0		2.78	2.2	5.36	3.0	9.54	4.0	14.66	4.9	24.61	6.3	42.71	8.3	2800.0	
2900.0		2.83	2.2	5.46	3.0	9.73	4.0	14.95	4.9	25.08	6.3	43.53	8.3	2900.0	
3000.0		2.88	2.2	5.56	3.0	9.91	4.0	15.23	5.0	25.55	6.4	44.34	8.3	3000.0	
3100.0		2.94	2.2	5.66	3.0	10.09	4.0	15.50	5.0	26.00	6.4	45.14	8.3	3100.0	
3200.0		2.99	2.2	5.76	3.1	10.27	4.0	15.77	5.0	26.46	6.4	45.92	8.3	3200.0	
3300.0		3.04	2.2	5.86	3.1	10.44	4.1	16.04	5.0	26.90	6.4	46.69	8.4	3300.0	
3400.0		3.09	2.2	5.96	3.1	10.61	4.1	16.30	5.0	27.34	6.4	47.45	8.4	3400.0	
3500.0		3.14	2.2	6.05	3.1	10.78	4.1	16.56	5.0	27.78	6.4	48.20	8.4	3500.0	
3600.0		3.19	2.2	6.15	3.1	10.95	4.1	16.82	5.0	28.20	6.5	48.94	8.4	3600.0	
3700.0		3.24	2.2	6.24	3.1	11.11	4.1	17.07	5.0	28.63	6.5	49.67	8.4	3700.0	
3800.0		3.28	2.2	6.33	3.1	11.28	4.1	17.32	5.1	29.04	6.5	50.40	8.5	3800.0	
3900.0		3.33	2.3	6.42	3.1	11.44	4.1	17.56	5.1	29.46	6.5	51.11	8.5	3900.0	
4000.0		3.38	2.3	6.51	3.1	11.60	4.1	17.81	5.1	29.86	6.5	51.81	8.5	4000.0	
4100.0		3.42	2.3	6.60	3.1	11.75	4.1	18.05	5.1	30.27	6.5	52.51	8.5	4100.0	
4200.0		3.47	2.3	6.69	3.1	11.91	4.1	18.29	5.1	30.66	6.5	53.20	8.5	4200.0	
4300.0		3.51	2.3	6.77	3.1	12.06	4.2	18.52	5.1	31.06	6.6	53.88	8.5	4300.0	
4400.0		3.56	2.3	6.86	3.1	12.21	4.2	18.75	5.1	31.45	6.6	54.55	8.6	4400.0	
4500.0		3.60	2.3	6.94	3.2	12.36	4.2	18.98	5.1	31.83	6.6	55.22	8.6	4500.0	
4600.0		3.65	2.3	7.03	3.2	12.51	4.2	19.21	5.1	32.21	6.6	55.88	8.6	4600.0	
4700.0		3.69	2.3	7.11	3.2	12.66	4.2	19.44	5.2	32.59	6.6	56.53	8.6	4700.0	
4800.0		3.73	2.3	7.19	3.2	12.81	4.2	19.66	5.2	32.96	6.6	57.18	8.6	4800.0	
4900.0		3.77	2.3	7.28	3.2	12.95	4.2	19.88	5.2	33.33	6.6	57.82	8.6	4900.0	
5000.0		3.82	2.3	7.36	3.2	13.09	4.2	20.10	5.2	33.70	6.6	58.45	8.7	5000.0	
5100.0		3.86	2.3	7.44	3.2	13.24	4.2	20.32	5.2	34.06	6.7	59.08	8.7	5100.0	
5200.0		3.90	2.3	7.51	3.2	13.38	4.2	20.54	5.2	34.42	6.7	59.70	8.7	5200.0	
5300.0		3.94	2.3	7.59	3.2	13.52	4.2	20.75	5.2	34.78	6.7	60.32	8.7	5300.0	
5400.0		3.98	2.3	7.67	3.2	13.65	4.2	20.96	5.2	35.13	6.7	60.93	8.7	5400.0	
5500.0		4.02	2.3	7.75	3.2	13.79	4.2	21.17	5.2	35.49	6.7	61.54	8.7	5500.0	
5600.0		4.06	2.3	7.83	3.2	13.93	4.3	21.38	5.2	35.83	6.7	62.14	8.7	5600.0	
5700.0		4.10	2.3	7.90	3.2	14.06	4.3	21.58	5.2	36.18	6.7	62.74	8.7	5700.0	
5800.0		4.14	2.3	7.98	3.2	14.19	4.3	21.79	5.2	36.52	6.7	63.33	8.8	5800.0	
5900.0		4.18	2.3	8.05	3.2	14.33	4.3	21.99	5.3	36.86	6.7	63.92	8.8	5900.0	
6000.0		4.22	2.3	8.13	3.2	14.46	4.3	22.19	5.3	37.20	6.7	64.50	8.8	6000.0	
6100.0		4.26	2.4	8.20	3.2	14.59	4.3	22.39	5.3	37.53	6.8	65.07	8.8	6100.0	
6200.0		4.29	2.4	8.27	3.2	14.72	4.3	22.59	5.3	37.86	6.8	65.65	8.8	6200.0	
6300.0		4.33	2.4	8.34	3.2	14.85	4.3	22.79	5.3	38.19	6.8	66.22	8.8	6300.0	
6400.0		4.37	2.4	8.42	3.3	14.97	4.3	22.98	5.3	38.52	6.8	66.78	8.8	6400.0	
6500.0		4.41	2.4	8.49	3.3	15.10	4.3	23.18	5.3	38.84	6.8	67.34	8.8	6500.0	
6600.0		4.44	2.4	8.56	3.3	15.23	4.3	23.37	5.3	39.16	6.8	67.90	8.8	6600.0	
6700.0		4.48	2.4	8.63	3.3	15.35	4.3	23.56	5.3	39.48	6.8	68.45	8.9	6700.0	
6800.0		4.52	2.4	8.70	3.3	15.48	4.3	23.75	5.3	39.80	6.8	69.00	8.9	6800.0	
6900.0		4.55	2.4	8.77	3.3	15.60	4.3	23.94	5.3	40.12	6.8	69.54	8.9	6900.0	
7000.0		4.59	2.4	8.84	3.3	15.72	4.3	24.13	5.3	40.43	6.8	70.09	8.9	7000.0	
7100.0		4.62	2.4	8.91	3.3	15.84	4.3	24.31	5.3	40.74	6.8	70.62	8.9	7100.0	
7200.0		4.66	2.4	8.97	3.3	15.96	4.3	24.50	5.3	41.05	6.8	71.16	8.9	7200.0	
7300.0		4.70	2.4	9.04	3.3	16.08	4.4	24.68	5.4	41.36	6.9	71.69	8.9	7300.0	
7400.0		4.73	2.4	9.11	3.3	16.20	4.4	24.87	5.4	41.66	6.9	72.22	8.9	7400.0	
7500.0		4.76	2.4	9.18	3.3	16.32	4.4	25.05	5.4	41.96	6.9	72.74	8.9	7500.0	

M = mass flow rate **kg/s** **l_e** = equivalent length of pipe **m** **Δp_l** = pressure loss per unit length **Pa/m** **v** = velocity **m/s**

Calculations for the Uponor MLC system

Install Times

The function of the calculation is the costing of construction works and the generation of an offer. Thereby a tender specification is produced in which the construction work required is described in detail.

The supplementary services specified right should be listed separately in the tender. The following specified installation times are based on the practical experiences of Uponor users. The following compiled installation times can represent only an approximate costing basis.

Before use all specifications are to be checked for correctness by the responsible engineer/plumber. Uponor does not take liability for the correctness of the specifications or for any possible consequential damages, which arose or can arise due to incorrect guidelines, except for gross negligence or if deliberately wrong data were supplied by Uponor or their agents.

Installation times include the work of two fitters and are indicated in group minutes.

Installation times contain the following work:

- Preparation of tools and supplementary equipment at the building site
- Reading the plans
- Pipe run calibration
- Pipe measurement, marking, cutting to length, bevelling and cleaning
- Pipe installation, including fastening
- Pressing

The following supplementary services are not covered in the installation time:

- Producing assembly schedules
- Setting-up and clearing the building site
- Day wages
- Insulation work
- Pressure test
- Construction control
- To prepare a bill of quantities

Installation time in group minutes (= 2 fitters) per running metre or fitting

Pipe dimension OD × s [mm]	Pipe in coil	Pipe in pipe pre-insulated	Pipe as straight length	Wall-disc	Elbow/Coupler/Reducer	Tee	Threaded connections
12 x 1.6	3.0	-	-	-	1.0	1.5	1.5
16 x 2.0	3.0	3.0	5.5	3.5	1.0	1.5	1.5
20 x 2.25	3.5	3.5	6.0	3.5	1.0	1.5	2.0
25 x 2.5	5.0	-	7.0	-	1.5	2.0	2.0
32 x 3.0	6.0	-	8.5	-	2.0	2.5	2.0
40 x 4.0	-	-	8.5	-	3.0	3.5	2.5
50 x 4.5	-	-	10.0	-	3.5	4.0	3.0
63 x 6.0	-	-	12.0	-	-	-	-
75 x 7.5	-	-	12.0	-	-	-	-
90 x 8.5	-	-	13.0	-	-	-	-
110 x 10	-	-	13.0	-	-	-	-

Installation time in group minutes (2 fitters) per modular fitting

Size of the fitting	Press adapter	Thread adapter	Basepart tee	Basepart elbow/coupler
RS 2	1.5	2.5	1.0	0.5
RS 3	1.5	3.0	1.0	0.5

Source: Survey of companies working with Uponor

Detailed calculation

The detailed calculation for each position has been made separately according to pipe and fitting.

Example to calculate the installation time

In a bathroom there are one basin, one shower and one toilet. They have to be installed in a Tee installation. How long does it take to install the pipe work from the riser to the tap connections?

Material	Unit	Group minutes/Unit	Summary
Uponor Unipipe MLC 16x2	7 m	3.0 min	21.0 min
Wall disc (tap connection)	5 pce	3.5 min	17.5 min
Uponor press tee MLC 16-16-16	3 pce	1.5 min	4.5 min

Two fitters need 43 minutes to install the pipe work.

Installation

Transport, storage and installation conditions

General

The Uponor multi-component pipe system is designed to guarantee that the system is absolutely safe if used correctly. All the system components must be transported, stored and processed in a way that ensures the installations function perfectly. The system components should be stored according to their system in order to prevent any components becoming mixed up with components for other applications. The instructions in the relevant installation instructions for the individual system components and tools should also be followed in addition to the following instructions.

Processing temperatures

The permissible processing temperature range for the Uponor multi-component pipe system (pipes and fittings) is between -10°C and $+40^{\circ}\text{C}$. See the relevant operating instructions and instructions for use for the individual devices for the permissible temperature ranges for the pressing tools.

Uponor multi-component pipes

During transport, storage and processing the pipes must be protected from mechanical damage, dirt and direct sunlight (UV radiation). Consequently, the pipes should be kept in their original packaging if at all possible until processed. This also applies to any pieces left over, which are intended for future use. The pipe ends must remain closed until they are processed to prevent dirt getting into them. Damaged, bent or deformed pipes must not be processed. Pipe boxes with ring binders can be piled on top of one another to a maximum height of 2m. In rigid pipe format the pipes must be stored in such a way that prevents them bending out of shape. The relevant Uponor storage instructions must be followed.

Uponor fittings

Uponor fittings must not be thrown or otherwise handled incorrectly. The fittings should be stored in their original packaging until processing in order to protect them from damage or dirt. Damaged fittings or fittings with damaged O-rings must not be processed.



Compatibility list Uponor pressing jaws/ external pressing tools

Explanation

Tool type		Uponor pressing jaw dimensions (UP75)		
Designation	Features	Type 16 to 32	Type 40 and 50 as single pressing jaws	Type 63 and Type 75 with pressing unit
Viega „existing“ type 1 Type 1	Type 1	Yes	No	No
Viega „new“ Type 2	Type 2, serial numbers starting from 96...; side rod for stud monitoring			
Mannesmann „existing“	Type EFP 1; Head cannot be rotated	Yes	No	No
Mannesmann „existing“	Type EFP 2; Head can be rotated	Yes	No	No
Geberit „existing“	Type PWH – 40; black sleeve over pressing jaws holder	Yes	No	No
Geberit „New“	Type PWH 75; blue sleeve over pressing jaws holder	Yes	No	No
Novopress	ECO 1/ACO 1	Yes	Yes	No
Novopress	AFP 201/EFP 201	Yes	Yes	No
Novopress	ACO 201	Yes	Yes	No
Ridge Tool/Von Arx	Ridgid RP300 Viega PT2 H	Yes	No	No
Ridge Tool/Von Arx	Ridgid RP300 B Viega PT3 AH	Yes	Yes	No
Ridge Tool/Von Arx	Viega PT3 EH	Yes	Yes	No
Ridge Tool/Von Arx	Ridgid RP 10B Ridgid RP 10S	Yes	No	No
Rothenberger	Romax Pressliner from 01/02/2004 from Ser. No. 010204999001	Yes	Yes	No
Rothenberger	Romax Pressliner ECO from 01/02/2004 from Ser. No. 010803777600	Yes	Yes	No
Rems	REMS Accu-Press ACC (Item - no. 571014)	Yes	Yes	No
Rems	REMS Power-Press ACC (Item - no. 577000)	Yes	Yes	No

As of 09/2013

Installation dimensions

Minimum pipe length before installation between two press fittings

Pipe dimension OD × s [mm]	Pipe length (L) in mm
12 × 1.6	min. 50
16 × 2.0	min. 50
20 × 2.25	min. 55
25 × 2.5	min. 70
32 × 3.0	min. 70
40 × 4.0	min. 100
50 × 4.5	min. 100
63 × 6.0	min. 150
90 × 8.5	min. 160
110 × 10.0	min. 160



Note:
The ends of the pipe must be bevelled before insertion in the fitting (see installation instructions).

Minimum space requirement for the press process with pressing tools (UP 75 and Mini 32)

Pipe dimension OD × s [mm]	Dim.: A mm	Dim.: B* mm
12 x 1.6	15	45
16 × 2.0	15	45
20 × 2.25	18	48
25 × 2.5	27	71
32 × 3.0	27	75
40 × 4.0	45	105
50 × 4.5	50	105
63 × 6.0	80	98
75 × 7.5	82	125

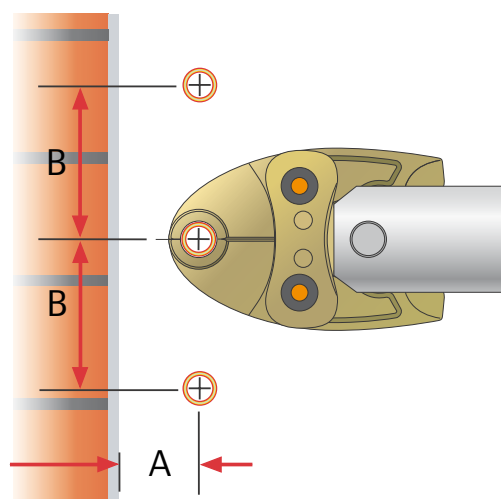

Pipe dimension OD × s [mm]	Dim.: A mm	Dim.: B* mm	Dim.: C mm
12 x 1.6	30	88	30
16 × 2.0	30	88	30
20 × 2.25	32	90	32
25 × 2.5	49	105	49
32 × 3.0	50	110	50
40 × 4.0	55	115	60
50 × 4.5	60	135	60
63 × 6.0	80	125	75
75 × 7.5	82	125	82

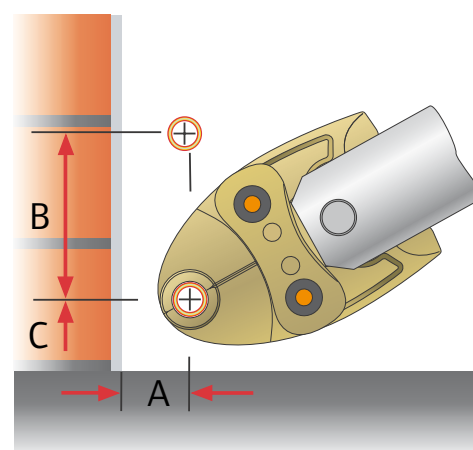

*With the same outer pipe diameter

Minimum space requirement for the press process with the manual pressing tool

Pipe dimension OD × s [mm]	Dim.: X [mm]	Dim.: Y [mm]	Dim.: Z* [mm]	Dim.: B [mm]	Dim.: H [mm]
12 × 1.6	25	50	55	510	510
16 × 2.0	25	50	55	510	510
20 × 2.25	25	50	55	510	510

* With the same outer pipe diameter

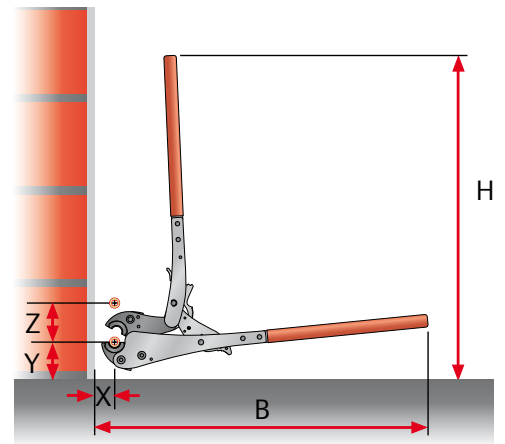

Installation method by Z-dimension

As a basis for efficient planning, work preparation and prefabrication, the Z-dimension method offers the plumber considerable advantages as far as ease of work and cost savings are concerned.

The basis for the Z-dimension method is a uniform measuring method. All the lines to be installed are measured over the axial line by measuring from centre to centre (intersection of the axial lines). (Example: $LR = LG - Z1 - Z2$)

With the help of the Z-dimensions of the Uponor press fittings, the plumber can quickly and easily calculate the exact length of pipe between fittings. Through exact clarification of the pipe routing and coordination with the architect, planner and chief engineer in advance of the actual installation, large sections of the system can be preassembled for cost-effective installation.

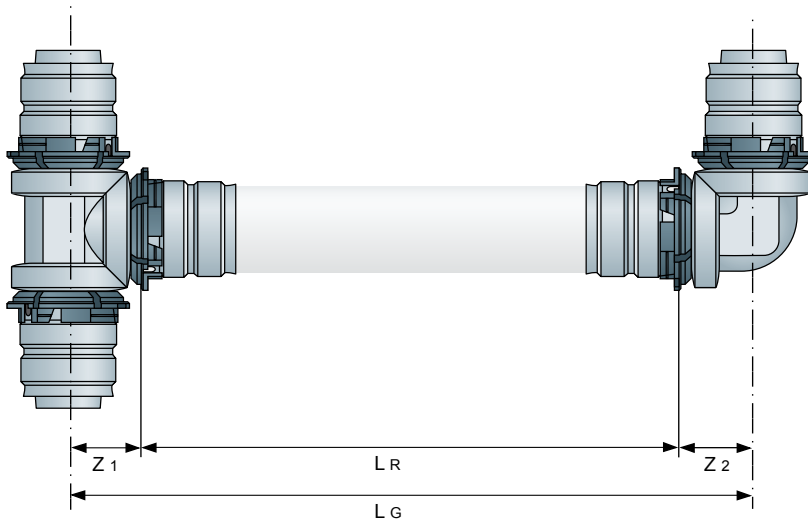

Note:

Z dimensions of individual fittings are available upon request from the Uponor Technical Department.

Bending Uponor MLC pipes

The Uponor MLC pipes

12 x 1.6; 16 x 2.0; 20 x 2.25; 25 x 2.5 and 32 x 3 mm can be formed by hand with a bending spring or bending tool. The minimum bending radii may not be less than those specified in the following table.

If a Uponor MLC pipe is inadvertently broken or otherwise damaged it is to be immediately replaced or a Uponor press or compression coupling is to be installed.



Caution!

Hot bending of Uponor MLC pipes over an open flame (e.g. soldering flame), or other heat sources (e.g. heat gun, industrial dryer) is prohibited! Do not bend more than once at the same point!



Note:

In this context make certain that the bending radius (e.g. in the area between floor and wall) does not fall below the minimum radius. If the minimum bending radius is not reached, a suitable fitting (e.g. a 90° press elbow) must be used.

Minimum bending radii

Minimum bending radii in mm with the following tools:

Pipe dimension OD x s [mm]	Bending radius by hand [mm]	Bending radius with internal spring [mm]	Bending radius with external spring [mm]	Bending radius with Uponor bending tool [mm]	Bending radius with REMS bending tool [mm]
12 x 1.6	(5 x OD) 60	(4 x OD) 48	-	-	-
16 x 2	(5 x OD) 80	(4 x OD) 64	(4 x OD) 64	46	-
20 x 2.25	(5 x OD) 100	(4 x OD) 80	(4 x OD) 80	80	-
25 x 2.5	(5 x OD) 125	(4 x OD) 100	(4 x OD) 100	83	-
32 x 3	(5 x OD) 160	(4 x OD) 128	-	111	-
40 x 4	-	-	-	-	160
50 x 4.5	-	-	-	-	200
63 x 6	-	-	-	-	252

OD = outer diameter s = wall thickness

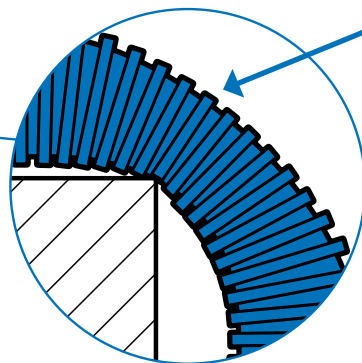
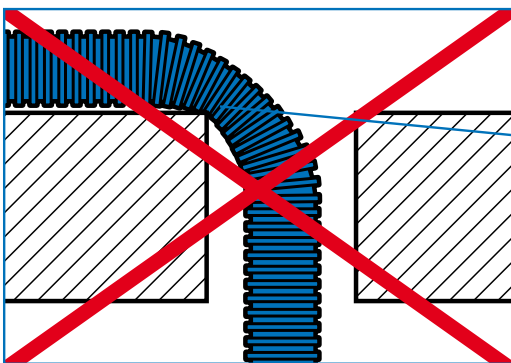

Uponor MLC within protective conduit

Pipes installed through ceiling recesses and wall cut-outs may never be bent over edges.

Mounting technology

Fitting and equipment connections as well as the connection of measuring and control devices are to be installed torsion-free.

All pipes are to be installed in such a manner that the thermal length variation (temperature change) is not obstructed.

The length variation between two fixed points can be compensated for with an expansion elbow, a compensator or by a change in the direction of the pipe.

No trays may be used if Uponor MLC pipes are installed open on the ceiling with pipe clips.

The following table represents the maximum mounting distance “L” between the individual pipe clips for different pipe dimensions.

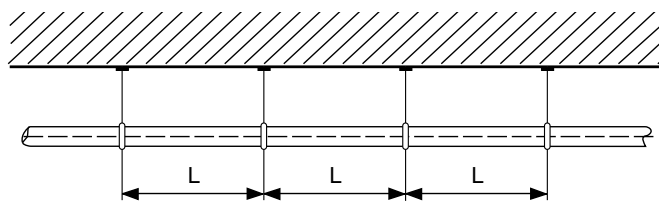

Pipe dimension OD x s [mm]	Maximum mounting distance between pipe clips L			Pipe weight with 10°C water filling/without insulation	
	horizontal		vertical [m]	Coil [kg/m]	Straight length [kg/m]
	Coil [m]	Straight length [m]			
12 x 1.6	1.20	-	1.70	0.128	-
16 x 2.0	1.20	1.60	1.70	0.218	0.231
20 x 2.25	1.30	1.60	1.70	0.338	0.368
25 x 2.5	1.50	1.80	2.00	0.529	0.557
32 x 3.0	1.60	1.80	2.10	0.854	0.854
40 x 4.0	1.70	2.00	2.20	-	1.310
50 x 4.5	2.00	2.00	2.60	-	2.062
63 x 6.0	2.20	2.20	2.85	-	3.265
75 x 7.5	2.40	2.40	3.10	-	4.615
90 x 8.5	2.40	2.40	3.10	-	6.741
110 x 10.0	2.40	2.40	3.10	-	9.987

Type and distance between the pipe fastenings is dependent on pressure, temperature and medium. The dimensioning of the pipe supports is to be determined from the total mass (pipe weight + medium weight + insulation weight) in accordance with the generally accepted rules of technology. It is recommended to set the pipe supports, if possible, in the proximity of the fittings and connectors.

Pipe installation onto the raw floor

When installing pipes on a concrete floor the generally accepted rules of technology are to be observed. The sound insulation is to be installed in accordance with Building Regulations Part E ‘Resistance to passage of sound’ (England and Wales), or equivalent Standard elsewhere, in above ground construction. The pipe thermal insulation should be in accordance with Building Regulations Part L (England & Wales) and equivalent Standard elsewhere.

Furthermore, the mobility of pipes during thermal expansion is to be taken into consideration (see section “Thermal length variation”).

If screeds are applied on insulating layers (floating screed), the relevant national rules for floor screeds in building construction should be followed.

The following additional points should be observed:

- “In order to accept the floating screed the load-bearing substrate must be sufficiently dry and have an even surface. The smoothness and tolerance must correspond to national regulations. It may not contain any peaks, pipes or anything similar that can lead to sound bridges or fluctuations in the screed thickness.
- Furthermore, for prefabricated heating floor screeds the special requirements of the manufacturer as to the smoothness of the load-bearing substrate are to be observed.

- If pipes are installed onto the load-bearing substrate they must be fixed. A smooth surface is to be created for the installation of the insulating layer – at least the sound insulation. The required construction height must be planned for.
- When installed, the levelling layer must exhibit a closed form. Fill may be used, if its serviceability is proven. Insulating materials may be used as a levelling layer.
- Sealing against ground moisture and non-accumulating seepage water are to be determined by the building planner and be prepared before installation of the screed.

The routing of the Uponor MLC pipes and other plumbing on concrete floors is to be done non-intersecting, straight and as axially parallel and parallel to the walls as possible.

The preparation of a plan before the installation of the pipe tracks and other plumbing makes the installation easier.

Mounting distances during pipe installation on a concrete floor

When installing Uponor MLC pipes on concrete floors a fixing distance of 80 cm is recommended. The pipe is to be fixed within a distance of 30 cm in front and behind each bend. Pipe crossings are to be fixed. The fixing can be done using a synthetic plugged hook for single or double pipe fixing. When using a perforated tape for fastening, you must make sure that the Uponor MLC with/without protective tube or insulation can freely move. Noise can be caused by the thermal expansion of the pipe if it is firmly fixed. If the Uponor MLC system is installed directly in the screed, any permanent pipe fittings must have suitable protected against corrosion. In order to prevent damage to the screed and floor covering, joints (expansion joints) are to be placed in the insulating layer and in the screed over construction joints. Uponor MLC pipes, which cross construction joints, must be sheathed in the joint area by using Uponor joint protection tube (20 cm protection each side of the expansion joint).

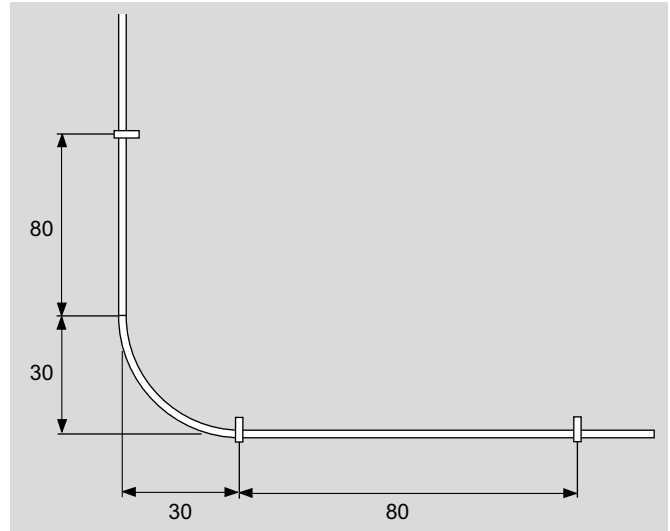

Pipe routing beneath solid floors

Pipes and other plumbing in the floor construction are to be planned without crossings. The routing of the pipes on concrete floors is to be done as non-intersecting, straight and as axially parallel and parallel to the walls as possible.

The following route dimensions for pipes and other plumbing should be maintained:

Field of application	Width or spacing dimension
Route width of parallel running pipes including pipe insulation	≤ 300 mm
Width of the footing beside a track (for the narrowest possible pipe-laying)	≥ 200 mm
Distances from wall to pipe/pipe route including insulation as footing for the screed in rooms, apart from corridors	≥ 500 mm
Distances from wall to pipe/pipe route including insulation as footing for the screed in corridors	≥ 200 mm

Distance from wall to pipe/pipe routes including insulation and screed in rooms, apart from corridors

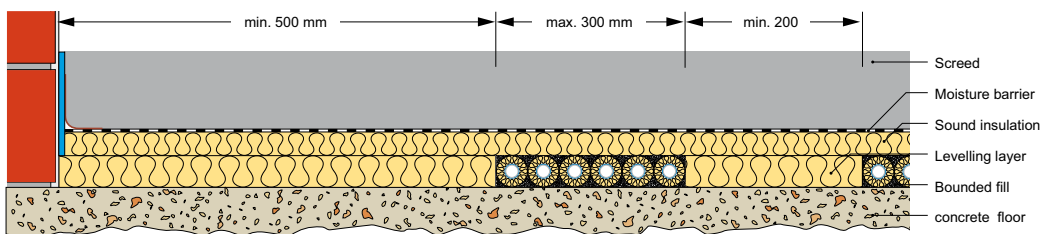

Distance from wall to pipe/pipe routes including insulation and screed in corridors

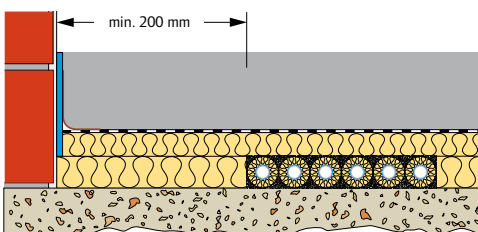

Notching and Drilling Joists

Holes should be drilled or notched in accordance with BS6700, BS5449 and NHBC regulations.

For plumbing installations Uponor prefer the use of drilling over notching for the following reasons:

- Improved health and safety because the installer can install pipes from below rather than work on open joists; holes for pipes can be drilled after the floor boards have been laid.
- Larger pipe sizes can be accommodated by drilling (0.25 x joist depth) as opposed to notching (0.125 x joist depth).
- No risk of damaging the pipes when the floor boards are fixed down.
- Thermal insulation can be more easily applied and accommodated.

The following is an accepted guide to avoid potential structural problems in domestic floors. Any notching or drilling outside of the permitted zones must be subject to structural calculations by a structural engineer to verify suitability. Joists can be weakened and become structurally unsound by: holes drilled off the centre line or near to the end of a joist, holes or notches made too close together and, notching too close to the centre of the joist span.

Prior to installing the plumbing pipe work attention should be given to planning the pipe routes to ensure that any holes/notches are within the permitted zones shown below.

Notching Zone Example

With a joist span of 3.5 metres between load bearing walls and joist depth of 225mm, the notching zone is:

Between 0.7×3.5 and $0.25 \times 3.5 = 0.245$ to 0.875 metres from each wall.

The permitted maximum depth of notch is: $0.125 \times 225 = 28\text{mm}$

Drilling Zone Example

With a joist span of 3.5 metres between load bearing walls and joist depth of 225mm, the drilling zone is:

Between 0.25×3.5 and $0.4 \times 3.5 = 0.875$ to 1.4 metres from each wall.

The permitted maximum diameter of hole is: $0.25 \times 225 = 56\text{mm}$

Notching

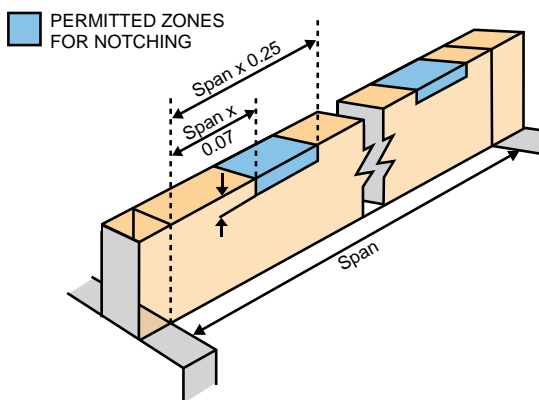

Drilling

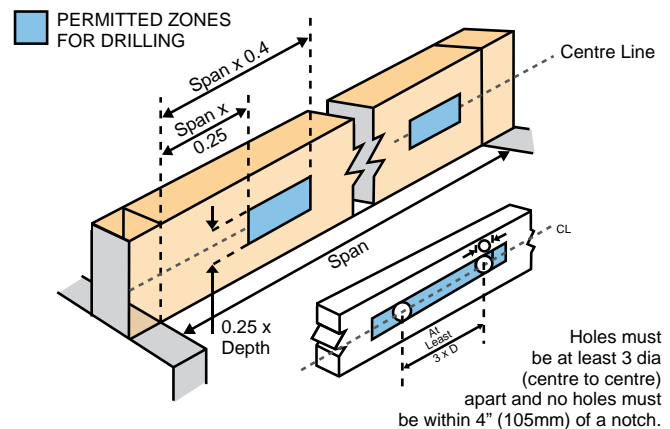

Engineered Joists

The flexibility of Uponor MLC pipe makes it ideally suited for cabling through knock-outs in the webbing of proprietary timber I beams, such as TJI joists used in silent floor systems.

The form stability of the MLC pipe prevents it from sagging between joists when hot water is circulating, which is a tendency with standard plastic piping systems.

Mounting Instructions

Uponor MLC pipe 12 – 110 mm

1. Cutting

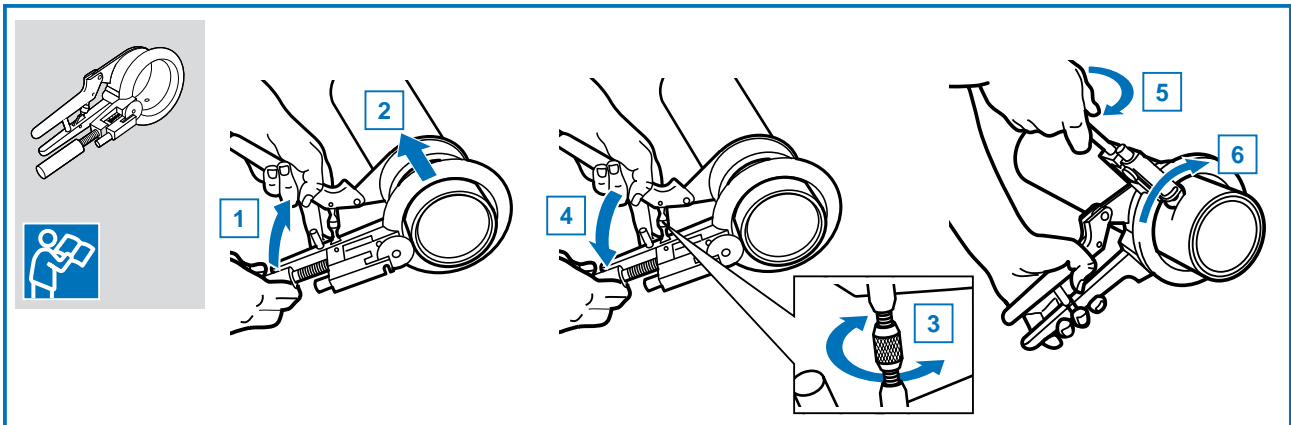
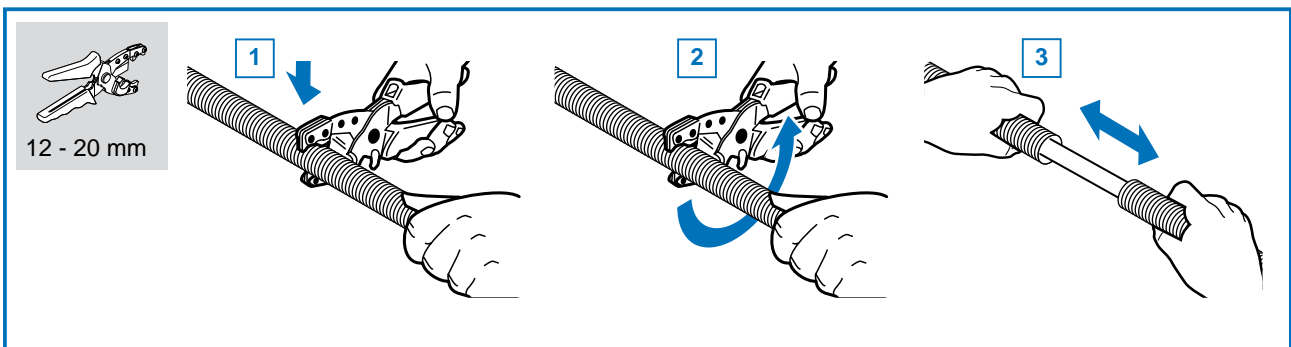
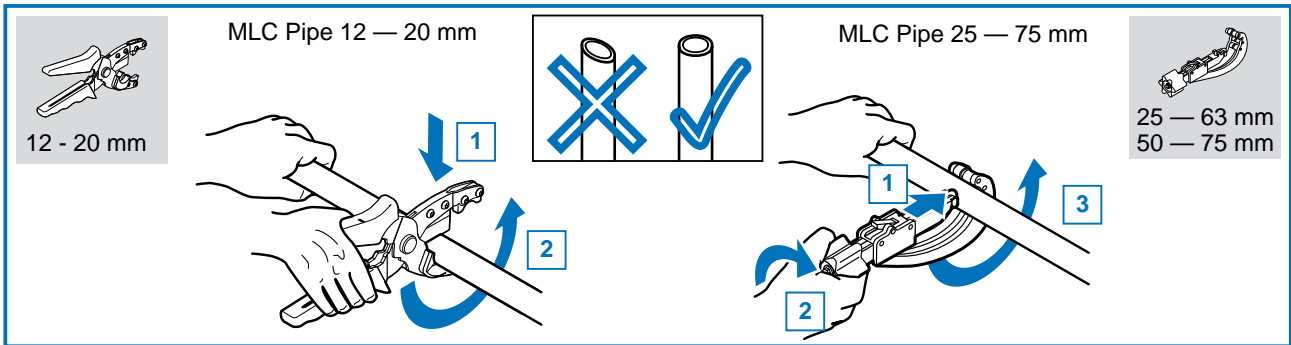

2. Bending

d_a [mm]	R_{min} [mm]
12	48
16	64
20	80
25	100
32	128

d_a [mm]	R_{min} [mm]
12	48
16	64
20	80
25	100
32	128

d_a [mm]	R_{min} [mm]
16	64
20	80
25	100

d_a [mm]	R_{min} [mm]
16	46
20	80
25	83
32	111
40	160
50	200
63	252

$$\Delta l \text{ [mm]} = \Delta\vartheta \text{ [K]} \cdot 0,025 \text{ [mm/mK]} \cdot L \text{ [m]}$$

$$BS \text{ [mm]} = 30 \cdot d_a \text{ [mm]} \cdot \Delta l \text{ [mm]}$$

3. Beveling

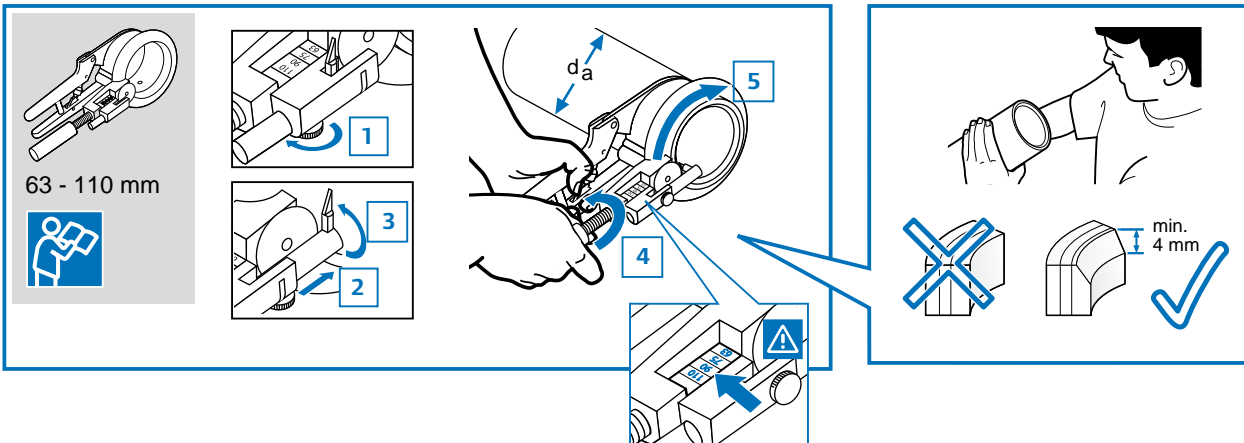
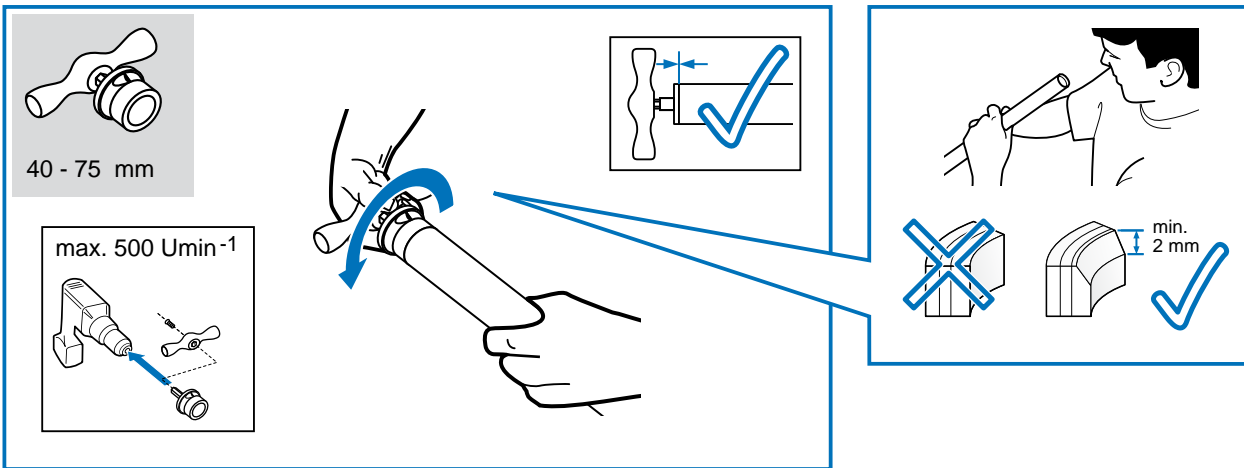
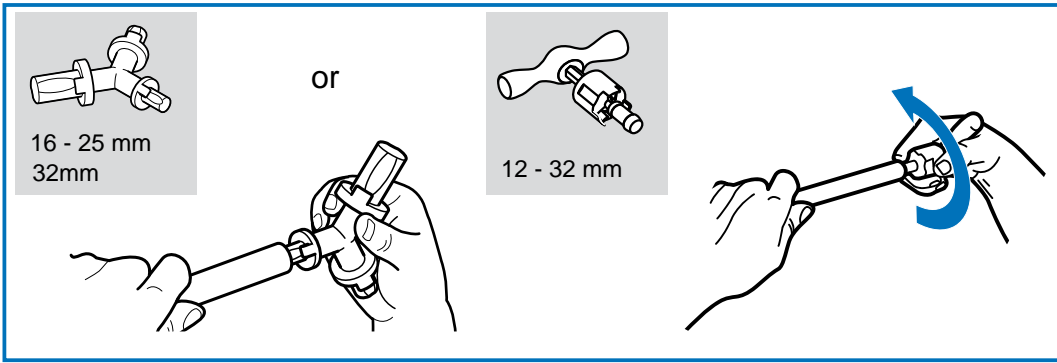

RTM only

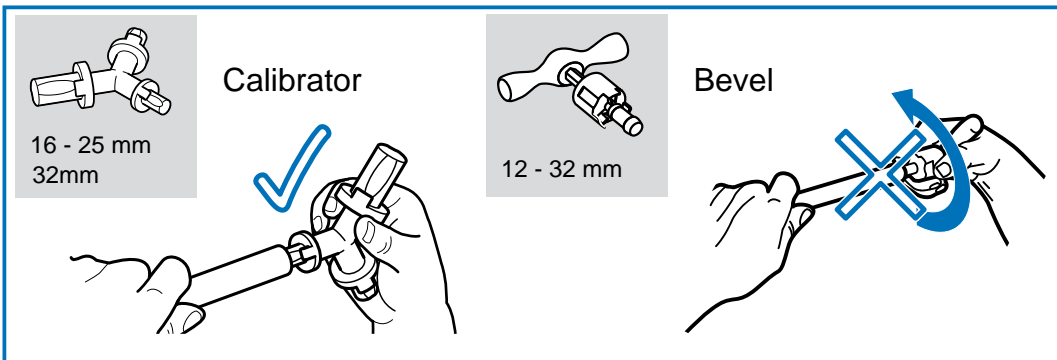

4. Assembly

Uponor tools							
Uponor Fittings							
	16 – 20	16 – 32	40 – 50	–	16 – 32	–	–
	12 – 20	16 – 32	–	–	16 – 32	–	–
	–	–	40 – 50	–	–	–	–
	–						–
	–	16 – 32	40 – 50	63 – 110	25 – 32	–	–
	–	–	–	–	–	12 – 25	–
	–	–	–	–	–	–	16 – 32

16 – 50 mm
PPSU

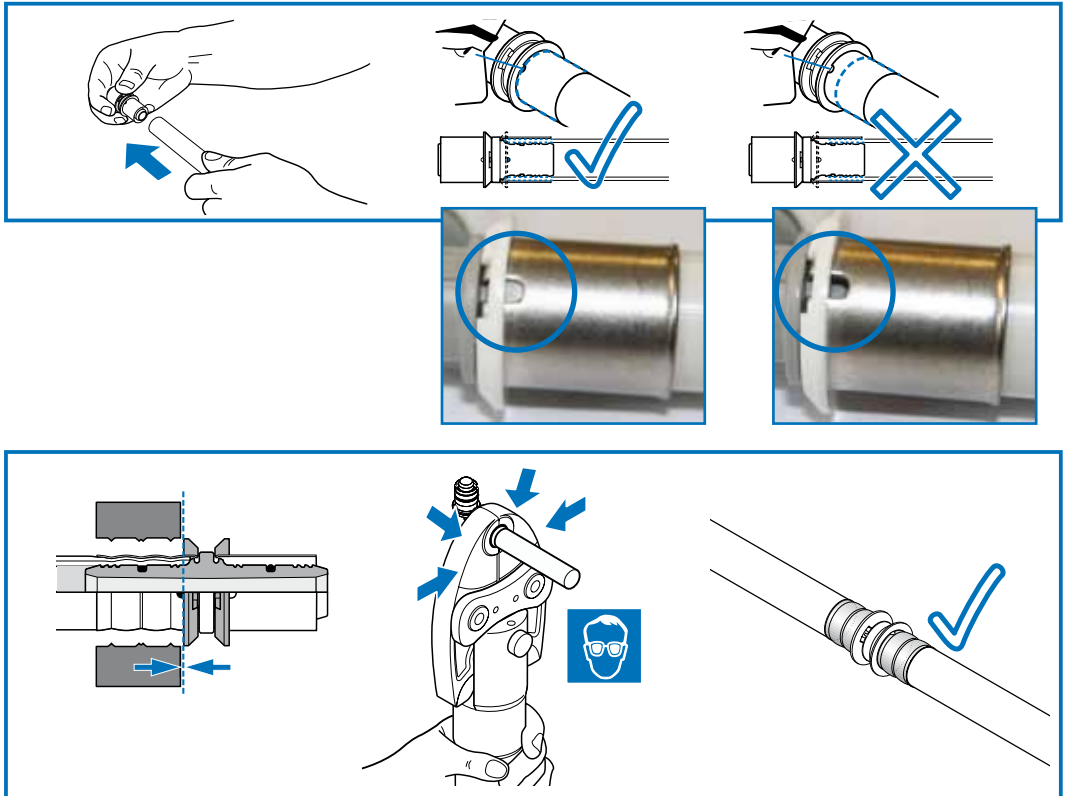

Compression Adaptor

12 – 32 mm

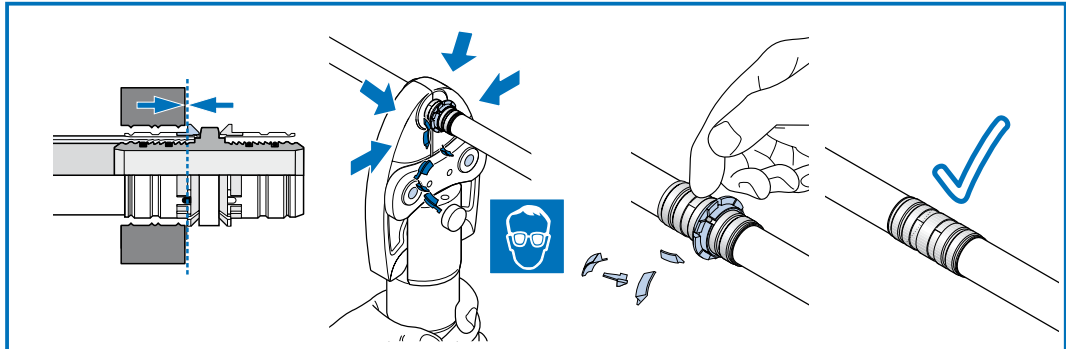
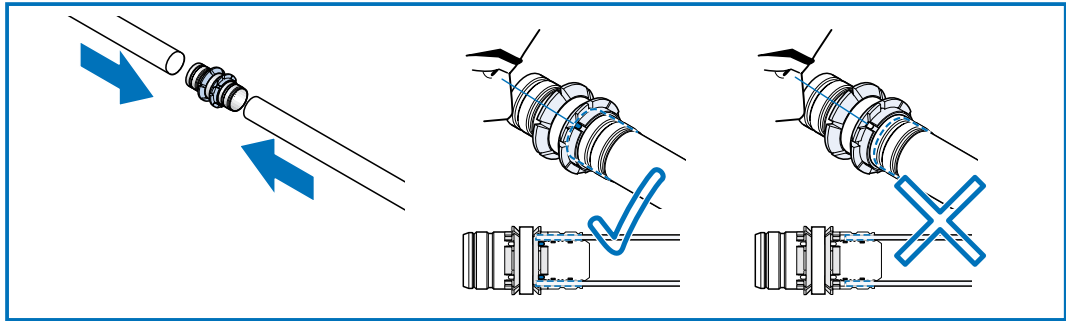

40 – 50 mm

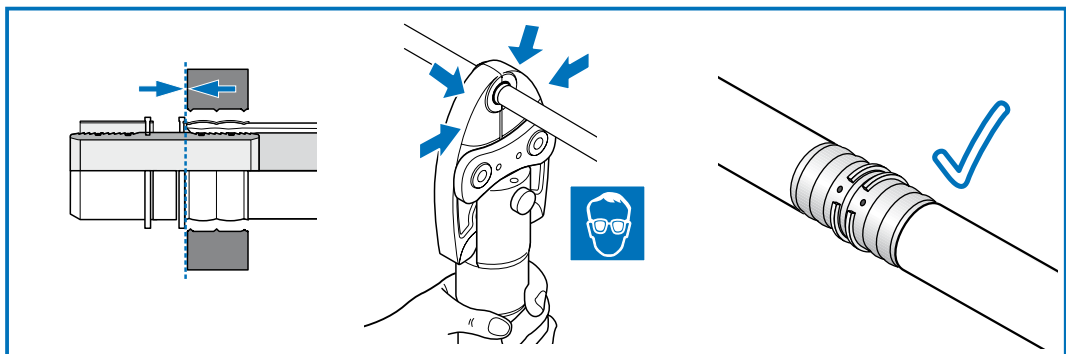
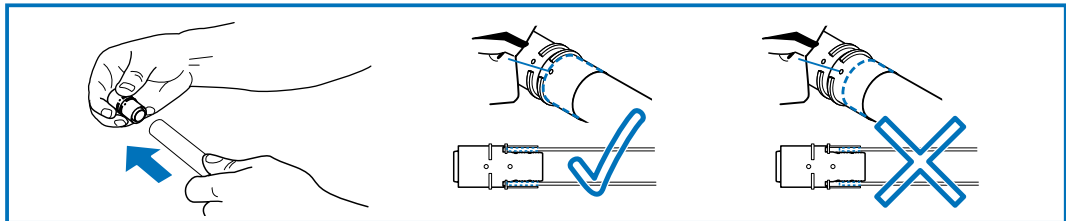
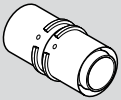

63 – 110 mm

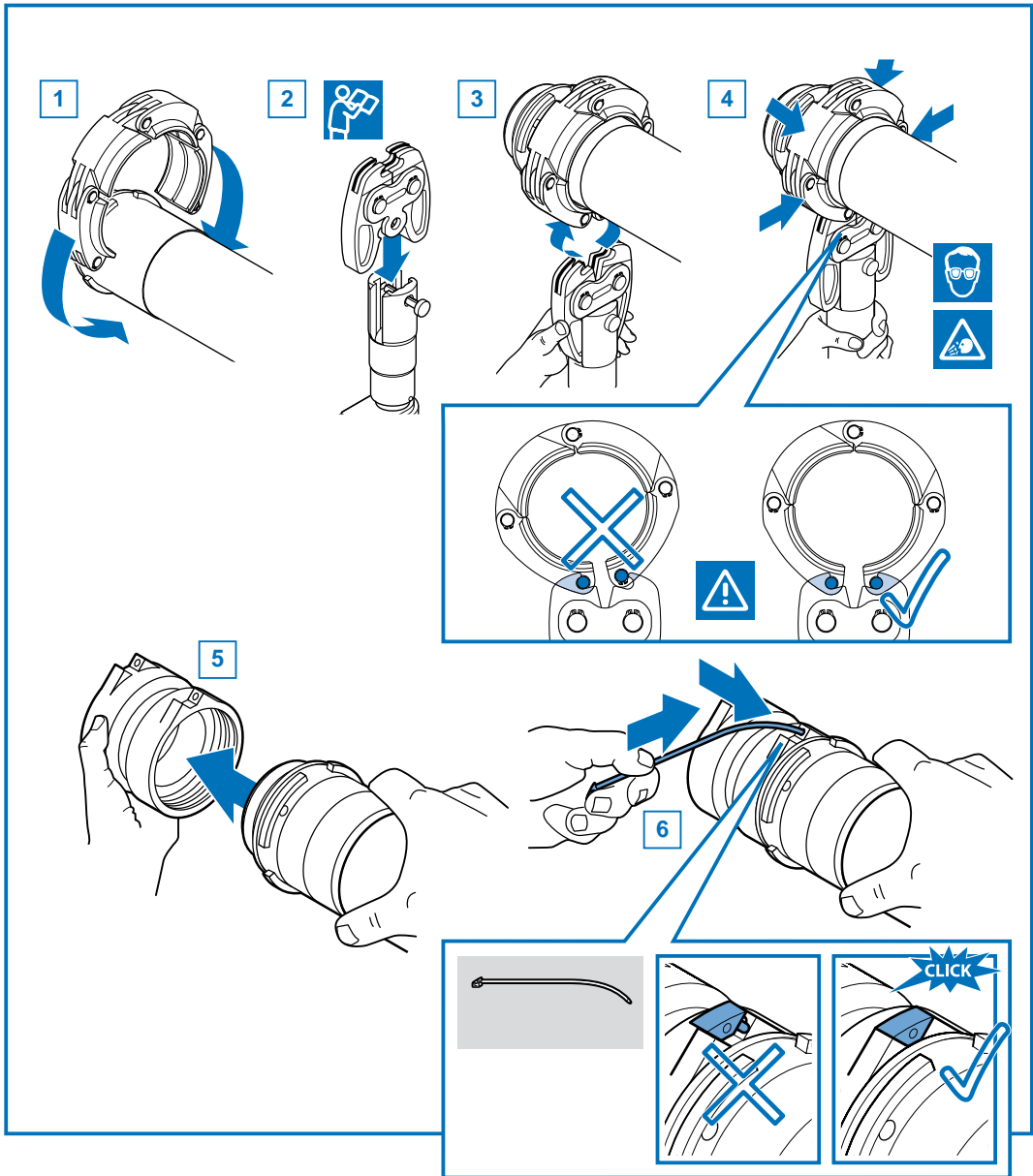
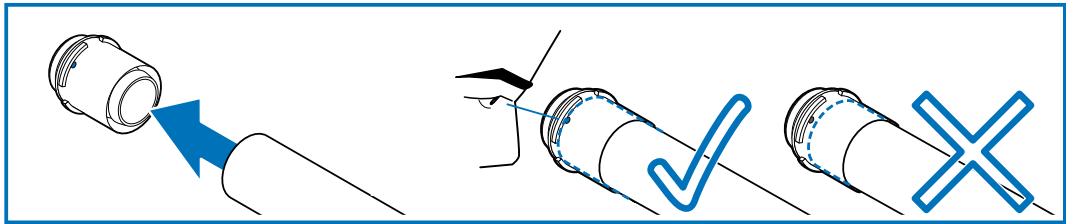
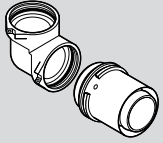

14 – 25 mm



PPSU

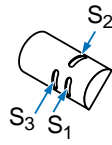
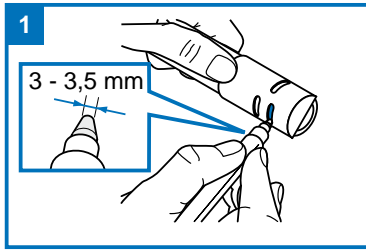

Fitting Dim.	S	Fitting Dim.	S
16 – 1/2"	S ₁	16 – 3/4"	S ₁
20 – 1/2"	S ₂	20 – 3/4"	S ₁
20 – M 22	S ₁	25 – 3/4"	S ₃

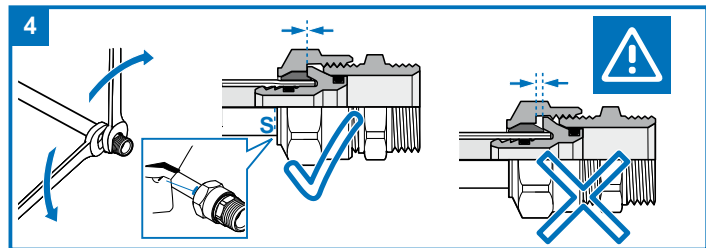
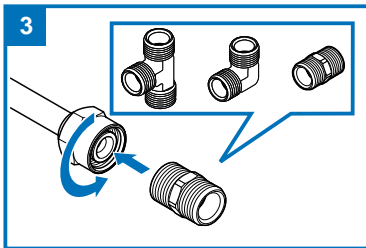
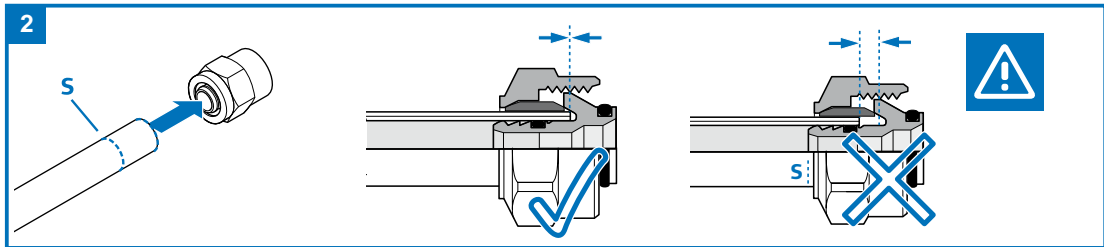

14 – 25 mm

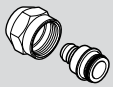

Metal

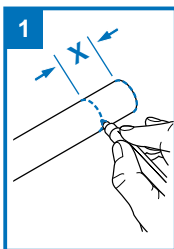

Fitting Dim.	X [mm]	Fitting Dim.	X [mm]	Fitting Dim.	X [mm]	Fitting Dim.	X [mm]
16 – 1/2"	8	16 – 3/4"	10	NL 16 – 15 mm	8	16 – M 22	9
20 – 1/2"	10	20 – 3/4"	10	NL 20 – 22 mm	10	16 – M 24	9
		25 – 3/4"	11	NL 25 – 22 mm	14		

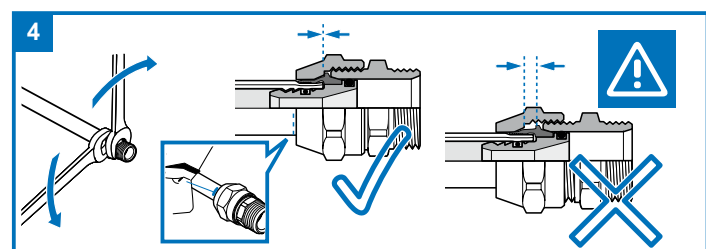
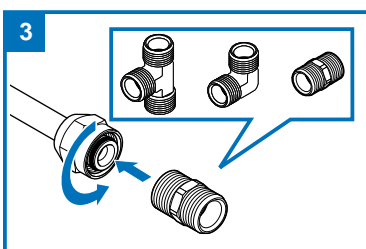
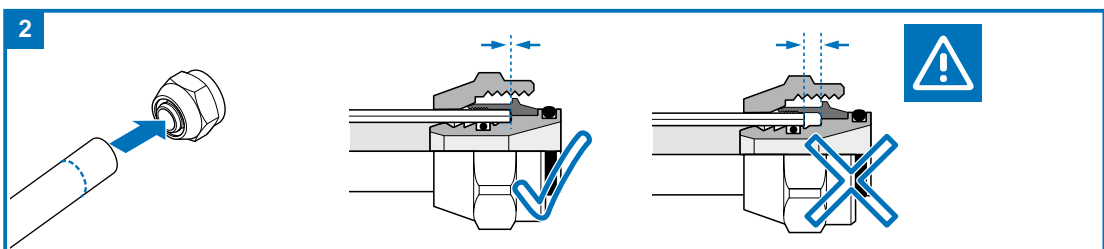

Uponor RTM

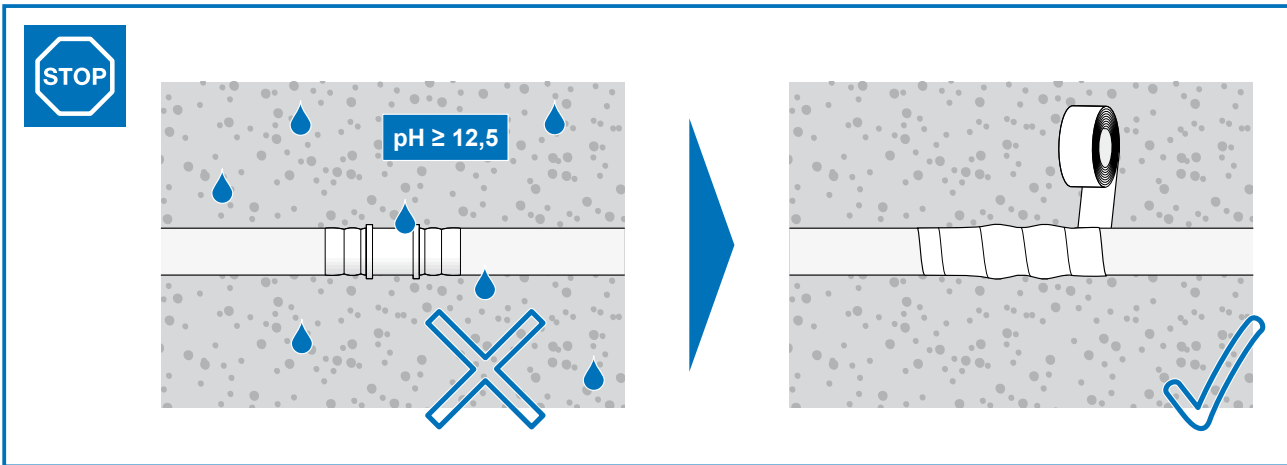
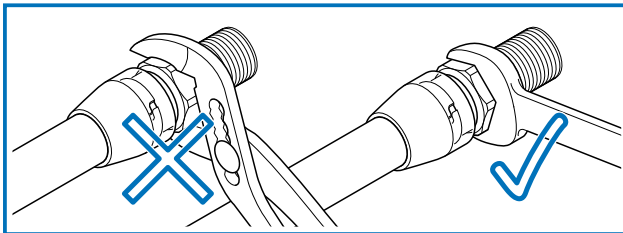
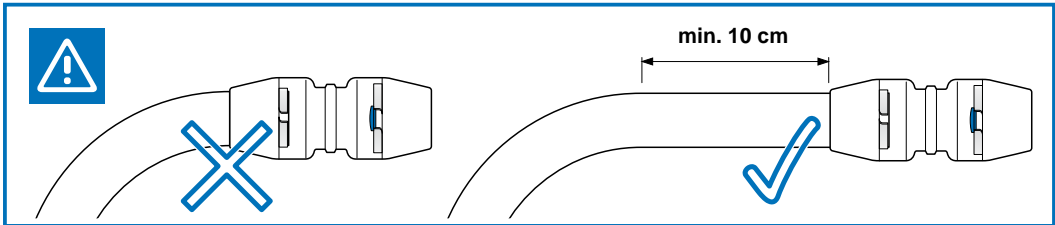
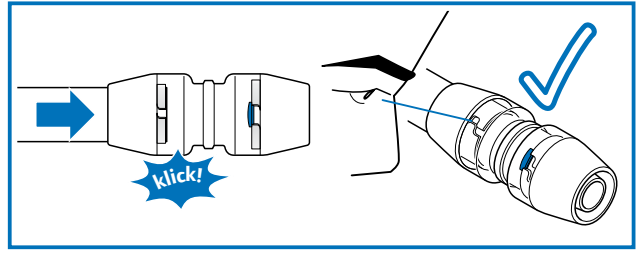
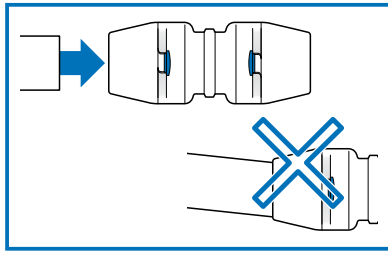
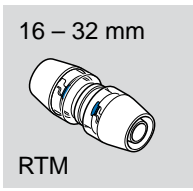

If exposed to the effect of permanent or constant humidity and pH value of over 12.5 at the same time, Uponor metal installation fittings must be covered with a suitable jacket, e.g. insulating tape, insulating material or a shrink sleeve.

Commission

Pressure testing the tap water installation

As for all tap water installations, a pressure test is also to be run for the Uponor MLC system. Before the pressure test, all components of the installation must be freely accessible and visible in order to be able to locate unpressed or incorrectly pressed fittings. All open pipes are to be closed with metal screw plugs, caps, blanking plates or blind flanges. Equipment, pressurized tanks or tap water heaters are to be separated from the pipes.

It is recommended to perform the pressure test with compressed air or an inert gas if the pipe system is to remain unfilled after the test. At the final inspection the pressure test and flushing must be done with water.

Pressure test with compressed air or inert gas

The pressure test with compressed air or inert gas is to be run in accordance with the generally accepted rules of technology in two steps, the leak test and the strength test. With both tests, before starting the test period, you must wait for temperature equalisation and steady-state condition after pressure build-up.

Leak test

A visual inspection of all pipe connections is to be made before the leak test. The pressure gauge used for the test must have an accuracy of 0.1 bar in the display range for the pressure being measured. The system is pressurised with a test pressure of 110 mbar. For a system volume of up to 100 litres the test period must be at least 30 minutes. The required time is extended by a further 10 minutes for every additional 100 litres. During the test no leakage may appear at the connectors.

Strength test

The strength test is to be run following the leak test. Here the pressure is raised to a maximum of 3 bar (pipe dimension $\leq 63 \times 6$ mm) or a maximum of 1 bar (pipe dimensions $\geq 63 \times 6$ mm). For a system volume of up to 100 litres the test period must be at least 30 minutes. The required time is extended by a further 10 minutes for every additional 100 litres.

Note: Please note you cannot air pressures test with Riser System.



Pressure testing with water

A visual inspection of all pipe connections is to be made before pressure testing with water. The pressure gauge must be connected at the lowest point of the installation being tested. Only measuring instruments may be used where a pressure difference of 0.1 bar can be read. The installation must be filled with filtered tap water (protect against frost!) and vented. Shut-off valves before and after boilers and tanks are to be closed so that the test pressure is kept away from the rest of the system. The system is to be pressurized with the maximum permissible operating pressure (10 bar) plus 5 bar (in relation to the lowest point of the system). Check the maximum operating pressure with pressure boosting systems! A suitable time must elapse to allow for the temperature equalisation between the ambient temperature and the temperature of the fill water. If necessary, the test pressure must be re-established after the waiting period.

Preliminary test

Re-establish the test pressure two times within 30 minutes at intervals of 10 minutes. After a further 30 minutes the test pressure must not have dropped by more than 0.6 bar.

Main test

The main test is to be run directly following the preliminary test. The pressure test is considered to have been passed successfully if the test pressure has not dropped by more than 0.2 bar after a further two hours.

After completion of the pressure test all fittings are to be checked for possible leakage. The results of the pressure test must be recorded in a report as a record for the plumber and customer. The forms at the end of this chapter can be used for this report.

- 1) All Uponor MLC fitting systems are suitable for both air and water pressure testing.
- 2) Correctly installed Uponor MLC systems can be filled, drained down and refilled without compromising security of fittings and water tightness of the pipe work installation.
- 3) It is not possible to remove the locking element from MLC modular component fittings when the system is under pressure.

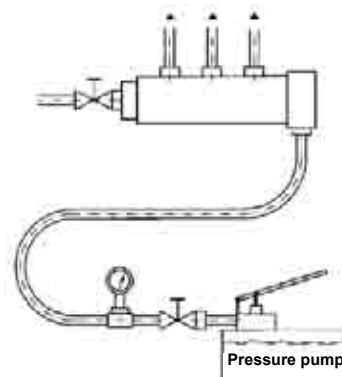

Pipe line flushing

The total system is to be flushed thoroughly as soon as possible after installation of the pipes and following the pressure test. Filtered tap water is to be used as flushing liquid. In order to ensure an unlimited operational reliability, flushing must remove all contamination and installation residue from the interior surfaces of the pipes and system components, to ensure the quality of the tap water as well as inhibit corrosion damage and malfunctions of the fittings and components. In general two flushing methods can be used:

Flushing with an air water mixture

This procedure is based on a pulsating flow of water and air. Suitable flushing equipment is to be used. This flushing procedure should be used if flushing with water is not expected to produce a sufficient flushing effect.

Flushing with water

If no other flushing method is contractually agreed upon or demanded, the Uponor tap water pipelines are to be flushed using the water method and local supply pressure. In order to protect sensitive fittings (e.g. solenoid valves, flushing valve, thermostats etc.) and equipment (e.g. tap water heater) against damage from flushed foreign matter adaptors should be initially installed in place of such components. Such components should only be installed after the system has been flushed. Built in fine-meshed sieves installed in front of fittings that cannot be removed or bypassed are to be cleaned

after flushing. Aerators, nozzles, flow limiters, shower heads or shower handsets must be removed from the remaining installed fittings during flushing. The manufacturers' installation instructions are to be followed for concealed thermostats and other sensitive fittings that cannot be removed during flushing. All maintenance fittings, floor shut-off valves and pre-shut-off valves (e.g. angle valves) must be fully opened. Possibly built-in pressure reducers must be fully opened and only be adjusted after flushing.

Depending on the size of the system and the pipe routing, the installation can be flushed in sections. In this case the flushing direction and sequence should be from the main isolation valve in sections and branches (actual flush section) from the nearest to the furthest branch. One floor after the other is to be flushed beginning at the riser pipe end.

Within the story and single supply lines at least as many usage points specified as a guideline in the following table for a section being flushed are to be fully opened one after the other for at least 5 minutes. This is to be repeated for each story. Within the story the usage points, beginning with the usage point furthest away from the riser pipe are to be fully opened. After a flushing period of 5 minutes at the flushing point last opened the usage points are closed one after the other in reverse order.

For the Uponor MLC pipe the following guidelines for the minimum number of usage points which are to be opened in relation to the largest inside diameter of the distribution conduit must be observed:

Pipe dimensions OD x s [mm] of the distribution conduit in the actual section being flushed	32 x 3	40 x 4	50 x 4.5	63 x 6	75 x 7.5	90 x 8.5	110 x 10
Minimum number of usage points to be opened DN 15	2	4	6	8	12	18	28

Pressure testing for the radiator installation

The following procedure describes the pressure test for the Uponor MLC system with screw or press connections.

The heating engineer/plumber has to perform a leak test on the heating pipes after installation and before closing wall slits, wall and floor breakthroughs as well as, if necessary, before the screed or other covering is laid.

The heating system is to be filled slowly and completely vented (protect against frost!). This can be done quickly and with little effort with the Uponor pressure test plug. Water heaters are to be checked with a pressure of 1.3 x the total pressure (static pressure) of the system; however, at least 1 bar excess pressure must be reached throughout the system. Only pressure gauges may be used that permit the accurate reading of a 0.1 bar pressure change. The pressure gauges is to be connected, if possible, to the lowest point of the system.

After the test pressure has been reached a suitable time must elapse to allow for temperature equalisation between the ambient temperature and the temperature of the fill water. If necessary, the test pressure must be re-established after the waiting period.

The test pressure must be maintained for 2 hours and may not drop by more than 0.2 bar. No leakages may appear during this time. As soon as possible after the cold water pressure test the system is heated to the highest calculated heating water temperature to check whether the system also remains leak-free at high temperature. After the system cools down the heating pipes and connections are to be checked for leaks.



Leak test record for Uponor drinking water installations. Test medium: Water

Note:

The accompanying explanations and descriptions in the current technical documentation of Uponor are to be observed.

Building project: _____

Building section: _____

Testing person: _____

Uponor installation system used: MLC composite pipe system PE-Xa installation system

All vessels, equipment and fittings, such as safety valves and expansion vessels that are not suitable for the test pressure have to be disconnected from the system to be tested during the pressure test. The system is filled with filtered water and vented completely. During the test a visible inspection of the pipe connectors and, at a modular fitting system, of the locking elements has to be carried out. The temperature compensation between the ambient temperature and the filling water temperature has to be taken into consideration by waiting correspondingly after the test pressure has been established. If required, the test pressure has to be restored after the waiting period.

1 Pressed connector leak test (if Uponor "unpressed untight" **press fittings** are used)

Test pressure: 3 bar

Test period: 15 minutes

The pipe system does not leak (visual inspection).

2 Leak Test, Part I

Test pressure: 11 bars (1.1 MPa), corresponding to 1.1 times the operating pressure in accordance with EN 806-4

Test period: 30 minutes

The pipe system does not leak (visual inspection, no pressure drop at the pressure gauge).

3 Leak Test, Part II

Test pressure: 5.5 bars (0.55 MPa), corresponding to 0.5 times the initial test pressure of leak test, Part I

Test period: 120 minutes

The test pressure at the pressure gauge was constant ($\Delta p = 0$) during the test period)

The pipe system does not leak.

Confirmation of the system tightness

Locality, date

Signature/contractor's stamp

Locality, date

Signature/contractor's stamp

Leak test record for Uponor drinking water installations. Test medium: Air pressure or inert gases

Following the ZVSHK guideline "Leak tests for drinking water installations using air pressure, inert gas or water"

Note:

The accompanying explanations and descriptions in the current technical documentation of Uponor are to be observed.

Building project: _____

Client represented by: _____

Contractor/responsible specialist
represented by: _____

Uponor installation system used: MLC composite pipe system PE-Xa installation system

System pressure: _____ bar

Ambient temperature: _____ °C

Test medium temperature: _____ °C

Pipe capacity: _____ liters

Test medium:

Oil-free compressed air Nitrogen Carbon dioxide _____

The drinking water system was tested

as complete system in _____ sections

All the lines have to be closed through metal plugs, covers, gaskets or blind flanges. Apparatuses, pressure vessels or drinking water heaters have to be disconnected from the piping. A visual inspection of all pipe connections for correct implementation was carried out.

1

Leak test

Test pressure 150 mbar (150 hPa)

Test period up to 100 liters line volume at least 120 minutes. The test period is to be increased by 20 minutes for every further 100 liters.

Test period: _____ minutes

The test period begins after the temperature compensation and steady state have set in.

No pressure loss occurred during the test period.

2

Load test

Test pressure: Uponor installation pipe $OD \leq 63$ mm max. 3 bar, Uponor installation pipe $OD > 63$ mm max. 1 bar

Test period: 10 minutes

The test period begins after the temperature compensation and steady state have set in.

No pressure loss occurred during the test period.

The pipe system does not leak.

Locality, date

Signature/contractor's stamp

Locality, date

Signature/contractor's stamp

Pressure test with compressed air or inert gas for tap water pipes

Testing method for partial acceptance, for the final inspection the pressure test.

Construction project: _____

Client represented by: _____

Contractor/person responsible

Specialist represented by: _____

Connection type: _____

System pressure: _____ bar

Test medium:

Ambient temperature: _____ °C

Oil-free compressed air Nitrogen Carbon dioxide _____

Test medium temperature: _____ °C

the tap water system was tested as

complete system in _____ sections

All pipes are to be closed with metal screw plugs, caps, blanking plates or blind flanges. Equipment, pressurized tanks or tap water heaters are to be separated from the pipes. A visual inspection of all pipe connections has been made in accordance with to good professional practice.

Leak test

Test pressure 110 mbar

Pipe capacity: _____ litre

At least 30 a minutes test period for pipe capacities up to 100 Litre

For each additional 100 litres the test period is to be increased by 10 minutes Test period: _____ minutes

The test period was started after the temperature and steady-state condition was established.

The test period was started after the temperature and steady-state condition was established.

During the test period no pressure drop was found.

During the test period no pressure drop was found.

Strength test with increased pressure

The pipe system has no leaks.

Test pressure: Uponor MLC pipe ≤ 63 x 6 mm max. 3 bar Uponor pipe > 63 x 6 mm max. 1 bar

At least 30 minutes test period for pipe capacities up to 100 litre

For each additional 100 litres the test period is to be increased by 10 minutes

Locality, date

Signature/contractor's stamp

Locality, date

Signature/contractor's stamp

Notes

A series of horizontal dotted lines for taking notes, spanning the width of the page.

Notes

A series of horizontal dotted lines for taking notes, spanning the width of the page.

Notes

A series of horizontal dotted lines for taking notes.

Uponor

**Uponor Limited
The Pavilion
Blackmoor Lane
Watford
Hertfordshire
WD18 8GA**

T 01923 927000
F 01923 223760
E enquiries.uk@uponor.com
W www.uponor.co.uk

