



Department of Safety and Professional Services
Division of Industry Services
Plumbing Product Review
4822 Madison Yards Way
P.O. Box 7162
Madison, Wisconsin 53707-7162
Phone 608-266-2112
Web <http://dsps.wi.gov>
Email dsps@wisconsin.gov
TTY: Contact Through Relay

Governor Tony Evers Dan Hereth, Secretary Designee

February 20, 2023

Uponor Inc.
Nate Koppi
5925 148th Street West
Apple Valley MN 55124

Re: Description: PEX-A Pipe and Fittings, Alternate Plumbing System
Manufacturer: Uponor Inc.
Product Name: AquaPEX Pipe and ProPEX Fittings: ½ - 3 in.
Model Number(s): AquaPEX Pipe and ProPEX Fittings: ½ - 3 in.
eSLA PTO No.: PP-022300004-PTOAA

The specifications and/or plans for this PEX-A Piping System have been reviewed and determined to be in compliance with chapters SPS 382 through 384, Wisconsin Administrative Code, and Chapters 145 and 160, Wisconsin Statutes.

The Department hereby issues an alternate approval to s. SPS 382.40(7)(e) and s. SPS 384.30(5)(b)3. based on the Wisconsin Statutes and the Wisconsin Administrative Code. This approval is valid until the end of February 2028.

This alternate approval is contingent upon compliance with the following stipulation(s):

1. A copy of this approval letter shall be submitted with all plans using this PEX-A piping system. Plans submitted without a copy of this approval letter may be denied.
2. This PEX piping system shall be installed, maintained and used in strict accordance with the manufacturer's published instructions, Chapters 381-386 Wis. Adm. Code and this product approval. If there is a conflict between the manufacturer's instructions and the Wis. Adm. Code or this Plumbing Product Approval, then the Wis. Adm. Code and this Plumbing Product Approval shall take precedence.
3. This PEX piping system shall be installed by persons holding the proper license or registration in accordance with Wis. Stats. § 145.
4. This PEX piping system shall only be installed for the following uses:
 - a. Water services and private water mains; and
 - b. Water distribution
5. The maximum cold water flow velocity for this PEX piping system is 10 ft./sec. (fps).
 - a. Cold water systems shall be sized in accordance with Appendix B (pages 91-100) of the attached Uponor "Plumbing Design Assistance Manual (PDAM)" 5th ed., 2019. See attached example.
6. The maximum hot water flow velocity for this PEX piping system is 8 ft./sec. (fps).
 - a. Hot water systems shall be sized in accordance with Table SPS 382.40-9 Wis. Adm. Code.
7. ASSE 1010-2004 compliant water hammer arrestors shall be installed as required by s. SPS 382.40 (8) (f) Wis. Adm. Code.
8. Pipe hangers and supports shall be installed for this PEX piping system in accordance with s. SPS 382.60 Wis. Adm. Code.

9. The manufacturer shall maintain conformance to ASTM F876 or ASTM F877, AWWA C904 and NSF/ANSI 14, NSF/ANSI/CAN 61, NSF/ANSI 359 and NSF/ANSI 372 for this pipe and associated fittings. Reinforcing cold-expansion rings and multiple outlet assemblies shall conform to ASTM F1960. Additionally, PEX piping systems installed within return air plenums shall conform to ASTM E84.
10. This approval shall include pre-sleeved and pre-insulated PEX piping.
11. This PEX piping system shall not be installed within 5 ft. of a UV light source or exposed to direct sunlight.

Technical notes:

- a. Manufacturer's website: <https://www.uponor-usa.com/en/search?query=aquapex>
<https://www.uponor-usa.com/en/search?query=propex>
- b. This alternate approval is required because the manufacturer is seeking a maximum flow velocity of 10 ft./sec. (fps) which exceeds the maximum velocity of 8 fps permitted by s. SPS 382.40 (7) (e) Wis. Adm. Code; and the porting on the 1¼ and 1½-in. ball valves are < one nominal pipe size smaller than the pipe being served.
- c. This approval supersedes the approval issued January 29, 2020 under eSLA PTO PP-022000002-PTOAA.

The department is in no way endorsing this PEX-A piping system, or any advertising, and is not responsible for any situation which may result from its use.

Sincerely,

Glen W. Schlüter
Plumbing Product Reviewer
Department of Safety and Professional Services
Division of Industry Services
Bureau of Technical Services
(608) 267-1401 **Phone**
glen.schlueter@wi.gov **E-mail**
7:45AM-4:30PM CST M-F **Work Hours**



SECTION 22 11 16

DOMESTIC WATER PIPING

PART 1 GENERAL

1.1 SECTION INCLUDES

- A. Domestic water piping and fittings for the following applications:
 - 1. Domestic cold water piping
 - 2. Domestic hot water piping
 - 3. Domestic hot water recirculation piping

1.2 RELATED SECTIONS

- A. Section 22 11 13 — Facility Water Distribution Piping
- B. Section 22 07 19 — Plumbing Piping Insulation
- C. Section 22 05 29 — Hangers and Supports for Plumbing Piping and Equipment

1.3 REFERENCES

- A. ASTM International (ASTM)
 - 1. ASTM D 2765 Test Methods for Determination of Gel Content and Swell Ratio of Crosslinked Ethylene Plastics.
 - 2. ASTM D 3350 Standard Specification for Polyethylene Plastics Pipe and Fittings Materials.
 - 3. ASTM D 6394 Specification for Sulfone Plastics (SP).
 - 4. ASTM E84 Standard Test Method for Surface Burning Characteristics of Building Materials.
 - 5. ASTM E119 Standard Test Methods for Fire Tests of Building Construction and Materials.
 - 6. ASTM F714 Standard Specification for Polyethylene (PE) Plastic Pipe (SDR-PR) Based on Outside Diameter.
 - 7. ASTM E814 Standard Test Method for Fire Tests of Through-Penetration Fire Stops.
 - 8. ASTM F876 Standard Specification for Crosslinked Polyethylene (PEX) Tubing.
 - 9. ASTM F877 Standard Specification for Crosslinked Polyethylene (PEX) Plastic Hot- and Cold-Water Distribution Systems.
 - 10. ASTM F1960 Standard Specification for Cold Expansion Fittings with PEX Reinforcing Rings for Use with Crosslinked Polyethylene (PEX) Tubing.
 - 11. ASTM F2023 Standard Test Method for Evaluating the Oxidative Resistance of Crosslinked Polyethylene (PEX) Pipe, Tubing and Systems to Hot Chlorinated Water
 - 12. ASTM F2657 Standard Test Method for Outdoor Weathering Exposure of Crosslinked Polyethylene (PEX) Tubing

- B. American Water Works Association
 - 1. AWWA C904 Standard for Crosslinked Polyethylene (PEX) Pressure Pipe, 1/2 in. Through 3 in., for Water Service.
- C. American National Standards Institute (ANSI)/National Sanitation Foundation (NSF)
 - 1. ANSI/NSF Standard 14 Plastics Piping System Components and Related Materials
 - 2. ANSI/NSF Standard 61 Drinking Water System Components - Health Effects
 - 3. ANSI/NSF Standard 359 Valves for Crosslinked Polyethylene (PEX) Water Distribution Tubing Systems
 - 4. ANSI/NSF Standard 372 Drinking Water System Components – Lead Content
- D. American National Standards Institute (ANSI)/Underwriters Laboratories, Inc. (UL)
 - 1. ANSI/UL 263 Standard for Safety for Fire Tests of Building Construction and Materials.
 - 2. ANSI/UL 2846 Standard for Fire Test of Plastic Water Distribution Plumbing Pipe for Visible Flame and Smoke Characteristics.
- E. American Society of Mechanical Engineers (ASME)
 - 1. ASME B 16.5 Pipe Flanges and Flanged Fittings: NPS 1/2 through NPS 24 Metric/Inch Standard.
 - 2. ASME B16.51 Copper and Copper Alloy Press-Connect Pressure Fittings.
- F. Canadian Standards Association (CSA)
 - 1. CAN/CSA B137.11 Polypropylene Pipe and Fittings for Pressure Applications
 - 2. CAN/CSA B137.5 Crosslinked Polyethylene (PEX) Tubing Systems for Pressure Applications.
 - 3. CSA B242-05 Groove-and Shoulder-Type Mechanical Pipe Couplings.
- G. City of Los Angeles, California
 - 1. Research Report RR-5482
- H. German Welding Society (DVS)
 - 1. DVS 2207-11:2008 Welding of Thermoplastics — Machines and Devices for Heating Element Welding of Pipes, Pipeline Parts and Sheets.
- I. Department of Housing and Urban Development
 - 1. Materials Release no. 1269f
- J. International Code Council (ICC)
 - 1. International Plumbing Code (IPC)
 - 2. Evaluation Service Report PMG-1006 and PMG-1412
 - 3. ICC-ES PMG — 1106
 - 4. International Association of Plumbing Officials (IAPMO)
 - 5. Uniform Plumbing Code (UPC)
 - 6. Evaluation Report 253

- K. State of Massachusetts Division of Professional Licensure
- L. National Association of Plumbing, Heating and Cooling Contractors (NAPHCC)
 - 1. National Standard Plumbing Code (NSPC)
- M. Plastics Pipe Institute (PPI)
 - 1. PPI Technical Report TR-4
- N. QAI Laboratories
 - 1. P321-1 Water Pipe Systems - Plumbing Product-Pipe and Accessories
 - 2. P321-2 Water Pipe Systems - Plumbing Product-Plastic Piping and Accessories
- O. Underwriters Laboratories (UL)
 - 1. UL 2846 Standard for Fire Tests of Plastic Water Distribution Plumbing Pipe for Visible Flame and Smoke Characteristics.
- P. Uponor Inc.
 - 1. Uponor Piping Systems Installation Guide, current edition.
 - 2. Uponor Plumbing Design Assistance Manual, current edition.

1.4 SUBMITTALS

- A. Submit under provisions of Section 01 30 00 — Administrative Requirements.
- B. Product data: Provide manufacturer's product submittal data.
- C. Shop drawings: Provide installation drawings indicating piping layout, size dimension by installation segment, vault locations, support fixtures and schedules with all details required for installation of the system.
- D. Samples: Submit selection and verification samples of piping.
- E. Quality assurance/control submittals
 - 1. Test reports: Upon request, submit test reports from recognized testing laboratories.
 - 2. Submit the following documentation.
 - a. Manufacturer's certificate stating that products comply with specified requirements.
 - b. Manufacturer's flow schedule for the distribution system.
 - c. Documentation that the installer is trained to install the manufacturer's products
- F. Closeout submittals: Submit the following documents.
 - 1. Warranty documents specified herein.
 - 2. Operation and maintenance data.
 - 3. Manufacturer's field reports specified herein.
 - 4. Final as-built piping layout drawing.

1.5 QUALITY ASSURANCE

- A. Installer qualifications: Installer shall have successfully completed the Uponor Piping Systems Training Course and is able to provide proof/verification. Course shall be conducted by the manufacturer or a manufacturer's representative.
 - 1. Regulatory requirements and approvals: Ensure the piping distribution system complies with all applicable codes and regulations.
 - 2. Certifications: Provide letters of certification indicating: Installer uses skilled workers holding a trade qualification license or equivalent, or apprentices under the supervision of a licensed tradesperson.
 - 3. Pre-installation meetings:
 - a. Verify project requirements, excavation conditions, system performance requirements, manufacturer's installation instructions and warranty requirements.
 - b. Review project construction timeline to ensure compliance or discuss modifications as required.
 - c. Interface with other trade representatives to verify areas of responsibility.
 - d. Establish the frequency and construction phase the project engineer intends for site visits and inspections by the tubing manufacturer's representative.

1.6 DELIVERY, STORAGE AND HANDLING

- A. General: Comply with Division 1 Product Requirement Section.
- B. Ordering: Comply with manufacturer's ordering instructions and lead-time requirements to avoid construction delays.
- C. Delivery: Deliver materials in manufacturer's original, unopened, undamaged containers with identification labels intact.
- D. Storage and protection: Store materials protected from exposure to harmful environmental conditions and at temperature and humidity conditions recommended by the manufacturer.
 - 1. Store PEX piping in cartons or under cover to avoid dirt or foreign material from entering the piping.
 - 2. Do not expose white PEX tubing to direct sunlight for more than one month or red or blue PEX tubing to direct sunlight for more than 6 months. If construction delays are encountered, cover the tubing to prevent exposure to direct sunlight.
 - 3. Store piping on a flat surface to prevent unwanted deformation.

1.7 WARRANTY

- A. Project warranty: Refer to Conditions of the Contract for project warranty provisions.
- B. Manufacturer's warranty: PEX-a manufacturer system warranty shall cover piping and fittings for a duration of 25 years from the date of installation. Piping system warranty shall apply to potable water distribution and water service systems constructed of pipe and fitting products sourced from the same manufacturer.

PART 2 – PRODUCTS

2.1 MANUFACTURERS

- A. Acceptable manufacturer: Uponor, located at: 5925 148th St. W.; Apple Valley, MN, 55124; toll-free: 800-321-4739; tel: 952-891-2000; email: NAspecifications@uponor.com; web: uponor-usa.com or uponor.ca.
- B. Substitutions: Not permitted.
- C. Requests for substitutions will be considered in accordance with provisions of Section 01 60 00 — Product Requirements.

2.2 DOMESTIC WATER PIPING AND FITTINGS

- A. Performance requirements:
 - 1. PEX-a piping and fittings shall meet the following pressure and temperature ratings per ASTM F876:
 - a. 200 degrees F (93 degrees C) at 80 psi (551 kPa).
 - b. 180 degrees F (82 degrees C) at 100 psi (689 kPa).
 - c. 73.4 degrees F (23 degrees C) at 160 psi (1,102 kPa).
 - 2. PEX-a piping and fittings shall be tested for compliance by an independent third-party agency.
 - 3. Minimum bend radius (cold bending): Six times the outside diameter.
 - 4. Show compliance with ASTM E119 and ANSI/UL 263 through certification listings through UL.
 - a. UL Design No. L557 1 hour wood frame floor/ceiling assemblies.
 - b. UL Design No. K913 2 hour concrete floor/ceiling assemblies.
 - c. UL Design No. U372 1 hour wood stud/gypsum wallboard wall assemblies.
 - d. UL Design No. V444 1 hour steel stud/gypsum wallboard wall assemblies.
 - 5. PEX-a piping shall be tested to comply with the ASTM F2023 requirement for minimum chlorine resistance at the end use condition of 100% of the time at 140°F (60°C) at 80 psi (0.55 MPa) gauge pressure.
 - a. PEX-a piping and tubing material designation codes shall be PEX 5106 or PEX 5306.
- B. Piping:
 - 1. **Uponor AquaPEX®**
 - a. PEX-a (Engel-method crosslinked polyethylene), ASTM F876 and F877 (CAN/CSA-B137.5), SDR 9, CTS, 1/2 inch (16mm) through 3 inch (75mm) nominal pipe size.
 - 2. Uponor **AquaPEX** pre-sleeved piping
 - a. High-density polyethylene (HDPE) corrugated sleeved PEX-a (Engel-method crosslinked polyethylene), ASTM F876 and F877 (CAN/CSA-B137.5), SDR 9, CTS, 1/2 inch (16mm) and 3/4 inch (19 mm) nominal pipe size.
 - 3. Uponor pre-insulated piping
 - a. Factory fabricated and assembled Uponor **AquaPEX** PEX-a piping with a closed-cell polyethylene foam insulation, 1/2 inch (16mm) through 2 inch (51mm) nominal pipe size.
 - 1) Insulation shall not be exposed to groundwater

C. Fittings:

1. Uponor ProPEX®

- a. Third-party certified to NSF 14 and ASTM F1960 cold-expansion with PEX reinforcing ring and shall comply with ASTM F876 and ASTM F877, 1/2 inch through 3 inch nominal pipe size fittings manufactured from the following material types:
 - b. Reinforcing cold-expansion rings shall be manufactured from the same source as PEX-a piping manufacturer and marked "F1960".
2. Uponor multiport tees and elbows: Multiple-outlet fitting complying with ASTM F877 (CAN/CSA B137.5); with ASTM F1960 inlets and outlets.
 3. Uponor manifolds: Multiple-outlet assembly with ASTM F 1960 outlets.
 - a. Type L copper branch manifold with lead-free brass valve outlets.
 - b. Type L copper branch manifold without valves, with lead-free brass outlets.

2.3 TRANSITION FITTINGS

A. PEX-to-metal transition fittings:

1. Manufacturers: Provide fittings from the same manufacturer of the piping.
2. Third-party certified to NSF 14 and ASTM F1960 cold-expansion with PEX reinforcing ring and shall comply with ASTM F876 and ASTM F877, 1/2 inch through 3 inch nominal pipe size fittings manufactured from the following material types:
3. PEX-a to thread transition: One-piece Lead free (LF) brass fitting with male or female threaded adapter and ASTM F 1960 cold-expansion end, with PEX-a reinforcing cold-expansion ring.
4. PEX-a to copper sweat transition: One-piece lead free (LF) brass fitting with sweat adapter and ASTM F 1960 cold-expansion end, with PEX-a reinforcing cold-expansion ring.
5. PEX-a to copper press transition: One-piece lead free (LF) brass fitting with one ASME B16.51 copper press end and one ASTM F1960 cold-expansion end, with PEX-a reinforcing cold-expansion ring.
6. PEX-a to flange transition: Two-piece fitting with one steel flange conforming to ASME B 16.5 and one lead free (LF) brass adapter conforming to ASTM F1960.
7. PEX-a to groove transition: One-piece lead free (LF) brass fitting with one CSA B242-05 groove end in either iron pipe size (IPS) or copper tube size (CTS) and one ASTM F1960 cold-expansion end, with PEX-a reinforcing cold-expansion ring.
8. PEX-a to water meter transition: Two-piece fitting with one NPSM union thread and one ASTM F 1960 cold-expansion end, with PEX-a reinforcing cold-expansion ring.

B. PEX-to-thermoplastic transition fittings:

1. PEX-a to CPVC transition: Thermoplastic fitting with one spigot or socket end and one ASTM F1960 cold-expansion end, with PEX-a reinforcing cold-expansion ring.

2.4 VALVES

- A. PEX-to-PEX, lead-free (LF) brass ball valves (1/2 inch (13 mm) through 2 inch (50 mm) nominal pipe size)
 - 1. Manufacturers: Provide ball valve(s) from the same manufacturer as the piping system.
 - 2. Full-port ball valve: two-piece, ASTM F1960 cold-expansion ends, with PEX-a reinforcing cold-expansion ring.
 - 3. LF brass valve with a positive stop shoulder.
 - 4. In compliance with 250 CWP, ANSI/NSF 359, ANSI/NSF 372, ANSI/NSF 14/61, cNSF-us-pw_G lead free 0.25% lead maximum, ASTM F1960, ASTM F877 (CAN/CSA B137.5).
 - 5. Provide stem extension kits for insulated piping.
- B. PEX-to-NPSM, lead-free (LF) full-port brass water meter service valve
 - 1. 3/4 inch PEX x 1 inch NPSM straight and elbow
 - 2. 1 inch PEX x 1-1/4 inch NPSM straight and elbow
 - 3. Metal and polypropylene NPSM union nut
 - 4. In compliance with 250 CWP, ANSI/NSF 359, ANSI/NSF 14/61, cNSF-us-pw_G lead free 0.25% lead maximum, ASTM F1960, ASTM F877 (CAN/CSA B137.5).

PART 3 – EXECUTION

3.1 EXAINATION

- A. Site verification of conditions: Verify that site conditions are acceptable for installation of the domestic water piping. Do not proceed with installation until unacceptable conditions are corrected.

3.2 INSTALLATION

- A. Install domestic water piping according to approved shop drawings and coordination drawings.
- B. Comply with manufacturer's product data, including product technical bulletins, installation instructions and design drawings, including the following.
 - 1. Install PEX piping system in compliance with the Uponor Plumbing Design Assistance Manual (PDAM), current edition, and the Uponor Piping Systems Installation Guide, current edition.
 - 2. PEX shall not be installed in areas within five feet of a UV light source, such as LED and fluorescent light fixtures or other UV generating devices.
 - 3. White PEX shall not be installed outdoors where it is exposed to direct sunlight light for more than one month; red or blue PEX shall not be installed outdoors where it is exposed to direct sunlight for more than six months.
 - 4. PEX piping shall be installed per ASTM E84 requirements for plenum applications.
 - 5. Install PEX-a Pipe Support and provide all required hangers and supporting strapping as required by manufacturer to provide a code compliant installation.
 - 6. Install PEX piping in straight runs free of sags and kinks and provide bend supports at all 1/2 inch and 3/4 inch drops.

7. All PEX piping penetrations through wall plates shall be protected or shielded as required to prevent damage to piping.
8. PEX tubing passing through metal studs shall use grommets or sleeves at the penetration.
9. Install PEX piping from the multiport tee or manifold to each fixture as a home run.
10. Install PEX-a Pipe Support, fixed anchor points and hangers in compliance with Uponor Plumbing Design Assistance Manual (PDAM) to minimize expansion and contraction.
11. Install PEX piping at each fixture with out of the wall support bracket to secure piping and prevent excess movement when water stops or shut valves are operated.
12. Install all PEX manifolds centered in access panels to permit servicing.

C. Below-ground and in-slab installation

1. Install PEX piping system in compliance with the Uponor Plumbing Design Assistance Manual (PDAM), current edition and the Uponor Piping Systems Installation Guide, current edition.
2. White PEX shall not be installed outdoors where it is exposed to direct sunlight light for more than one month; red or blue PEX shall not be installed outdoors where it is exposed to direct sunlight for more than six months.
3. Install support strapping as required by manufacturer to provide a code-compliant installation.
4. Install PEX piping free of kinks.
5. PEX piping penetrations through slabs shall be protected by PEX stand-up brackets or PVC bend supports to prevent damage to piping.
6. Install PEX piping from the manifold as a home run. No joints shall be installed in the slab.
7. Insulation shall not be exposed to groundwater.
8. The piping system will be installed with the fewest number of underground joints as possible.

D. Backfill

1. The piping system will be backfilled with clean sand material.
 - a. Minimum vertical distance from the bottom of the tubing to the trench floor is 4 inches (100 mm).
 - b. Minimum lateral distance from the side of the tubing to the trench wall is 6 inches (150 mm).
 - c. Install a minimum of 12 inches (300 mm) of clean fill over the top of the piping.
2. The balance of the trench can be backfilled with native soil void of stone greater than 2 inches (50m) in diameter.

E. Comply with manufacturer's product data, including product technical bulletins, installation instructions and design drawings, including the following:

1. Uponor Piping Systems Installation Guide, current edition.
2. Uponor Plumbing Design Assistance Manual, current edition.

F. PEX-a hangers and supports

1. Horizontal PEX-a piping: Install supports suitable for PEX-a piping in compliance with local codes and the Uponor Piping Systems Installation Guide, current edition.
 - a. Note: Per ICC PMG-1006, the above maximum hanger spacing requirements may be extended with the use of a continuous support channel such as Uponor PEX-a Pipe Support.
2. Horizontal PEX-a piping with PEX-a Pipe Support: Install supports for PEX-a piping with horizontal support channel in accordance with manufacturer's recommendations and the following maximum spacing:
 - a. 3 inch nominal and smaller: Maximum span, 8 feet (2.4 m).
 - b. Support 1-1/2 inch and smaller fittings within 12 inches (0.3 m).
 - c. Install clamps and fixed points per the Uponor Piping Systems Installation Guide, current edition.
3. Vertical PEX-a piping: Install supports suitable for PEX-a piping in compliance with local codes and the Uponor Piping Systems Installation Guide, current edition:
 - a. Support vertical in-wall piping every 5 feet (1.5 m).
 - b. Support riser piping at the base of each floor and every 5 feet (1.5 m) vertically.
 - 1) Refer to the Uponor Piping Systems Installation Guide, current edition, for additional requirements.

G. Piping schedule

1. Above ground domestic water piping shall be the following:
 - a. 3 inch (75mm) and smaller
 - 1) PEX-a piping with engineered polymer (EP) or lead-free brass ASTM F1960 cold-expansion fittings.
 - b. 2 inch (51mm) and smaller:
 - 1) Pre-Insulated PEX-a piping with engineered polymer (EP) or lead-free brass ASTM F1960 cold-expansion fittings.
2. Domestic water piping installed below ground shall be any of the following:
 - a. 3 inch (75mm) and smaller:
 - 1) PEX-a piping with engineered polymer (EP) or lead-free brass ASTM F1960 cold-expansion fittings. No joints or fittings shall be installed under slab. Protect all slab penetrations.
 - b. 2 inch (51mm) and smaller, not exposed to groundwater:
 - 1) Pre-Insulated PEX-a piping with engineered polymer (EP) or lead-free brass ASTM F1960 cold-expansion fittings. No joints or fittings shall be installed under slab. Protect all slab penetrations.
3. Domestic water piping installed within slabs shall be the following:
 - a. 3 inch (75mm) and smaller:
 - 1) PEX-a piping. No joints or fittings shall be installed within slab. Protect all slab penetrations.
 - b. 1/2 inch (13 mm) and 3/4 inch (19 mm):
 - 1) Pre-sleeved PEX-a piping. No joints or fittings shall be installed within slab. Protect all slab penetrations.

- c. 2 inch (51mm) and smaller:
 - 1) Pre-Insulated PEX-a piping. No joints or fittings shall be installed within slab. Protect all slab penetrations.

H. Pipe joint construction

- 1. PEX-a connections:
 - a. Install per manufacturer's recommendations.
 - b. Use manufacturer-recommended cold-expansion ProPEX tool for ASTM F1960 connections.

3.3 FIELD QUALITY CONTROL

- A. Pressure testing PEX pipe and fittings: Pressure test PEX-a piping systems in accordance with local code and manufacturer's requirements.
- B. System flushing, pressure testing and system conditioning procedure:
 - 1. Hydrostatic pressure testing shall be completed in accordance with local Codes and the Uponor Plumbing Design Assistance Manual (PDAM).
 - 2. Leave joints uninsulated and exposed for the duration of the test.
 - 3. Flush the domestic water system with ambient temperature, clean, potable water unless there is a risk of damage due to freezing.
 - 4. After completing each hydrostatic leak testing procedure, drain the system until empty.
 - 5. If testing with compressed air, do not exceed 120 psi.

3.4 CLEANING

- A. Remove temporary coverings and protection of adjacent work areas.
- B. Repair or replace damaged installed products.
- C. Clean the installed products in accordance with manufacturer's instructions prior to Owner's acceptance.
- D. Water system disinfection
 - 1. Uponor AquaPEX piping should be disinfected in accordance with AWWA C651, Standard for Disinfecting Water Mains, or local codes.
 - 2. Use non-petroleum-based cleaners
 - 3. Not exceed a pH of 11
 - 4. Have water temperatures less than 140°F (60°C)
 - 5. Use a chlorine solution of 50 parts per million (ppm) for 24 hours or 200 ppm for three hours for disinfection.
 - 6. To prevent reduced service life of system components, disinfection solutions should not stand in the system longer than 24 hours. Flush the system with potable water after disinfection.

3.5 PROTECTION

- A. Protect installed work from damage caused by subsequent construction activity on the site.

END OF SECTION

uponor

Piping systems installation guide



Piping systems installation guide

is published by

Uponor Inc.

5925 148th Street West
Apple Valley, MN 55124
USA

T 800.321.4739

F 952.891.2008

Uponor Ltd.

6510 Kennedy Road
Mississauga, ON L5T 2X4
CANADA

T 888.994.7726

F 800.638.9517

uponorpro.com

uponorengineering.com

© 2019 Uponor, All rights reserved.

Printed in the United States of America

This piping systems installation guide is published for mechanical contractors, installers and building officials interested in Uponor PEX piping systems. It describes general installation recommendations that use Uponor PEX piping products. Refer to local codes for additional requirements.

Uponor made reasonable efforts to collect, prepare and provide quality information and material in this installation guide. However, system enhancements may result in modification of features or specifications without notice.

Uponor is not liable for installation practices that deviate from this installation guide or are not acceptable practices within the mechanical trades, codes or standards of practice.

Prior to installing Uponor piping systems, Uponor recommends all installers attend Uponor piping systems installation training performed by an Uponor trainer or manufacturer's representative. To schedule a training session at your business or job site, contact your local Uponor representative or call 800.321.4739.

Direct any questions regarding the suitability of an application or a specific design to a local Uponor representative by calling 888.594.7726 (U.S.) or 888.994.7726 (Canada).

Table of contents

Important safety information	ii
Standards, codes and listings	1
Making a ProPEX® connection	1
Cutting large-diameter PEX pipe	6
Troubleshooting a ProPEX connection	7
Verifying ProPEX connections	8
Minimum distance between fittings	8
Bending PEX	9
Uponor PEX ultraviolet (UV) resistance ratings	10
Storing and handling guidelines	10
Supporting Uponor PEX pipe	12
Supporting Uponor multiport tees	13
Strapping	15
Bundling	15
Main/corridor straight-length piping	16
Expansion and contraction	17
Installing Uponor PEX-a Pipe Support	19
Supporting large-diameter valves	23
Vertical support requirements	24
Risers	27
Fire-resistant construction	29
Below-grade installation	38
In-slab installation	39
Pressure testing	40
Water system disinfection	41

Table of contents

Appendix A: Dimensions and physical characteristics of Uponor PEX pipe	42
Appendix B: Hydrostatic temperature and pressure ratings.	43
Appendix C: ProPEX fitting dimensions	45
Appendix D: Uponor piping systems installation test questions	75

Important safety information

To reduce the risk of injury, read and understand this piping systems installation guide before beginning work.

Read all product safety warnings and operator's manuals for the Milwaukee® Tool M12™, M18™ and FORCE LOGIC™ ProPEX expansion tools, ProPEX 201 corded expander tool, PEX pipe cutters and other installation tools to operate those tools safely and correctly.

Always wear safety goggles or safety glasses with side shields when performing work.



WARNING: Cancer and Reproductive Harm
www.P65Warnings.ca.gov

Standards, codes and listings

Uponor PEX pipe and ProPEX fittings are designed to all applicable industry standards, codes and listings. Refer to our product submittals on uponorpro.com for complete details.

Making a ProPEX® connection

Important installation information

- Use only Milwaukee® ProPEX expander heads or Uponor standard expander heads on Milwaukee tools. Using incorrectly sized expansion heads may result in faulty connections which could result in leaking and property damage.
- Uponor standard expansion heads do not auto-rotate on Milwaukee ProPEX expansion tools. If using Uponor standard expansion heads, be sure to manually rotate the pipe or tool after each expansion to prevent deep grooves and faulty connections which could result in leaking and property damage.
- Ensure the Milwaukee expansion head is rotating during each expansion. This ensures no deep grooves on the inside of the pipe.
- Do not force the tool into the pipe.
- Improper lubrication (too much or too little) on the expansion cone and head may result in faulty connections which could result in leaking and property damage.
- Always remove the battery pack before changing or removing accessories, and only use accessories specifically recommended for the tool.
- Recharge only with the charger specified for the battery. For charging instructions, refer to the tool manual.



Figure 1: Expansion with proper rotation



Figure 2: Expansion without proper rotation

- To reduce risk of injury and damage, never immerse the tool, battery pack or charger in liquid or allow a liquid to flow inside the tool.
- Always unplug the charger and remove the battery pack from the charger or tool before performing any maintenance. Never disassemble the tool, battery pack or charger.
- Contact Milwaukee Tool at 800.SAWDUST (800.729.3878) for all service and repair work.



Figure 3: Milwaukee M12™ ProPEX expansion tool for 3/8" to 1" pipe

Figure 4: Milwaukee M18™ ProPEX expansion tool for 3/8" to 1 1/2" pipe

ProPEX connections with Milwaukee tools

Refer to the following steps to make ½" to 3" ProPEX connections. Each expansion tool features slight differences in operation. Use the Milwaukee M12 ProPEX expansion tool for ½" to 1" connections; use the Milwaukee M18 ProPEX expansion tool for ½" to 1½" connections.



Figure 5: Square cut the pipe.



Figure 6: Place the ProPEX ring over the end of the pipe.



Figure 7: Expand the pipe and ring until it reaches the collar. Then complete a minimum of one more expansion.



Figure 8: Insert the ProPEX fitting fully to the pipe stop.

Making ⅜" ProPEX connections

When making a ⅜" ProPEX connection, expand the ring once on each side to properly fit over the piping. Refer to the following instructions to make a ⅜" ProPEX connection.

1. Square cut the PEX piping perpendicular to the length of the piping. Remove all excess material or burrs that might affect the fitting connection.
2. Expand each side of the ring once.
3. Slide the expanded ring over the end of the piping. Extend the end of the ring over the end of the piping no more than ⅛" (1mm).
4. After the ring is on the piping, continue with the regular steps for making a proper connection with your specific tool.



Uponor ProPEX 201 corded expander tool

Use the ProPEX 201 corded expander tool to make 2" ProPEX connections.

Figure 9: ProPEX 201 tool

Note: The ProPEX 201 corded expander tool head does not manually rotate like the Milwaukee tool heads. It is important to properly rotate the pipe or tool after each expansion to prevent deep grooves in the piping. Failure to do so could result in leaking and property damage.

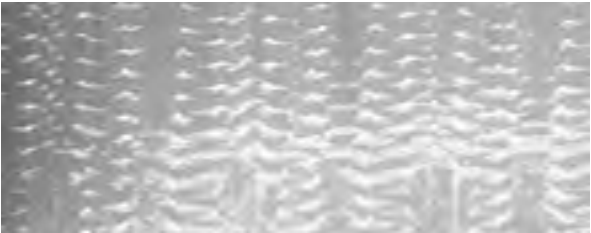

Figure 10: Expansion with proper rotation



Figure 11: Expansion without proper rotation

**Milwaukee M18
FORCE LOGIC™
ProPEX expansion tool**

Use the Milwaukee
M18 FORCE LOGIC
tool for 2" to 3" pipe.



**Figure 12: Milwaukee
M18 FORCE LOGIC
ProPEX expansion tool**



**Figure 13: When installing 2"- 3" heads, ensure
the cogs are aligned and engaged with the tool.**



**Figure 14: Expander head
collar should sit tight against
the tool.**



**Figure 15: If not installed
correctly, the expander
head will "flower".**

Cutting large-diameter PEX pipe



CAUTION: Read and thoroughly understand all safety instructions in the pipe cutter operator's manuals before performing work.



CAUTION: Be sure to wear safety gloves and proper eye protection prior to cutting pipe. Failure to do so could result in personal injury.

Use a swing or ratchet-type cutter to create smooth, clean cuts.



Figure 16: Uponor swing-style pipe cutter for up to 4" pipe (E6084000)



Figure 17: Uponor ratchet-style pipe cutter for up to 3" pipe (E6083000)

Troubleshooting a ProPEX connection

1. Ensure the expansion tool is properly maintained and in good working condition.
2. Ensure the expansion head is securely tightened onto the tool; frequently check that the head remains securely tightened throughout the installation process.
3. Ensure the segment fingers are not bent.
4. Remove excess grease.
5. Check the fitting for damage. Nicks and gouges will cause the fitting to leak.
6. Make sure the last expansion is not held in the expanded position before inserting the fitting.
7. Ensure proper rotation is occurring.
8. If a ProPEX ring slips, make sure that the outer pipe surface is clean and clear of any liquids. Inspect that the stop edge is present on the ProPEX ring.

Cold-weather expansions

Temperatures affect the time required for the piping and ring to shrink onto the fitting. Follow the below steps when making expansions in cold weather.

1. Warming the ProPEX fittings and ProPEX rings reduces contraction time. Put fittings and rings in your pockets prior to installation to keep them warm.
2. Make ProPEX connections at temperatures above 5°F (-15°C).
3. Fewer expansions are necessary in temperatures below 40°F (4.4°C).
4. Perform a test connection for each pipe size when temperatures differ from day to day, keeping note of the number of expansions to make a snug-fitting connection.

Verifying ProPEX connections

Ensure the ProPEX ring is tight against the fitting shoulder.



Figure 18: Coupling shoulder



Figure 19: Tee shoulder

Minimum distance between fittings

Uponor requires a minimum distance between ProPEX fittings to avoid damaging the fittings during installation and to protect against elevated stress on the pipe and fittings.

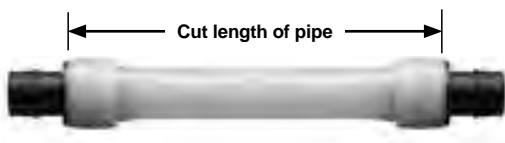

Figure 20: Minimum PEX length between fittings

Table 1: Minimum PEX cut length

Pipe size	Minimum cut length of pipe
½"	2" (51mm)
⅝"	2½" (64mm)
¾"	3" (76mm)
1"	3½" (89mm)
1¼"	4½" (114mm)
1½"	4½" (114mm)
2"	6" (152mm)
2½"	7½" (191mm)
3"	9" (229mm)

Bending PEX

Uponor PEX bend radius

The minimum bend radius of Uponor AquaPEX pipe is six times the outside diameter. Bend supports are available for $\frac{3}{8}$ ", $\frac{1}{2}$ ", $\frac{3}{4}$ " and 1" piping and may be used to facilitate 90-degree rigid bends. Use large-diameter PVC conduit to facilitate 90-degree bends in larger-diameter Uponor PEX piping.

Table 2: Bending Uponor PEX

Pipe size	Pipe O.D.	Min. bend radius	2 x O.D.
$\frac{1}{2}$ "	0.625"	$3\frac{3}{4}$ " (95mm)	$1\frac{1}{4}$ " (32mm)
$\frac{3}{4}$ "	0.875"	$5\frac{1}{4}$ " (133mm)	$1\frac{3}{4}$ " (44mm)
1"	1.125"	$6\frac{3}{4}$ " (171mm)	$2\frac{1}{4}$ " (57mm)

To alleviate stress on ProPEX connections and fittings, do not change direction immediately after a ProPEX connection.

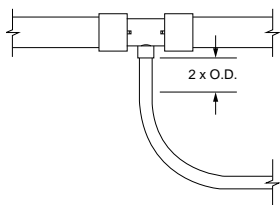

Figure 22: Correct bending



Figure 21: Bend radius

Uponor recommends a minimum of two times the outside diameter (O.D.) of the pipe as the minimum distance before changing direction; however, it is up to the installer to use best judgment. See **Figures 22** and **23** for guidance.

Note: When a proper bend is not possible, use a ProPEX elbow.

Note: Uponor recommends the use of elbows in sizes $1\frac{1}{4}$ " and larger for directional changes unless adequate space is available for a proper bend.

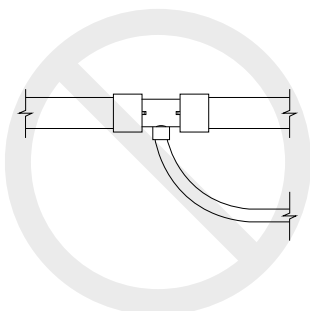

Figure 23: Incorrect bending

Uponor PEX ultraviolet (UV) resistance ratings

Table 3: Uponor PEX UV resistance ratings

Product	Marking	UV resistance
Uponor AquaPEX white	5106	1 month
Uponor AquaPEX blue	5306	6 months
Uponor AquaPEX red	5306	6 months
Wirsbo hePEX™	5106	1 month

Note: Uponor AquaPEX Reclaimed Water pipe has not been tested for UV resistance.

UV from light fixtures

Do not install PEX within 5 ft. (1.5m) of direct view from fluorescent and LED lights unless protected with a UV-blocking material (i.e., approved insulation or plastic wrap/sleeve).

Storing and handling guidelines

- Uponor PEX may be connected directly to electric water heaters, as well as power-vented gas water heaters where allowed by local code.
- Protect Uponor PEX with grommets when passing through metal framing members.
- Do not store Uponor PEX piping outdoors. Keep the piping in the original packaging until the time of installation.
- Do not use Uponor PEX piping where temperatures and pressures exceed limits.
- Do not weld, glue or use adhesives or adhesive tape with Uponor PEX piping.
- Do not apply open flame to Uponor PEX piping.
- Do not install Uponor PEX within 6" (15.2cm) of a vent pipe for direct or gravity-vented appliances.*

*Maintain a minimum 1" (25mm) distance from double-wall B vents or zero-clearance plastic vents.

- Do not install Uponor PEX piping within 12" (0.3m) of any recessed light fixture unless the piping is protected with suitable insulation or the light is Insulation Contact (I.C.) rated. Note that PEX must maintain a minimum 2" (51mm) clearance unless insulated with a suitable insulation.
- Do not solder, braze, weld or fusion-weld within 18" (45.7cm) of any Uponor PEX piping in the same water line. Make any heat-related connections prior to making the ProPEX connection.
- Use ProPEX lead-free (LF) brass copper press adapters for a flameless transition.
- Do not spray on or allow organic chemicals, strong acids or strong bases to come into contact with Uponor PEX piping.
- Only use closed-cell spray foams approved for use with PEX pipe.
- Avoid spray foam contact with Uponor engineered polymer (EP) fittings.
- Do not use petroleum or solvent-based paints, greases or sealants on Uponor PEX piping. For chemical compatibility questions, contact Uponor Technical Services at 888.594.7726 (U.S.) or 888.994.7726 (Canada).
- Do not install Uponor PEX piping between the tub/shower valve and the tub spout.
- Do not use Uponor PEX piping for an electrical ground.
- Do not press Uponor ProPEX brass sweat fittings. For copper press systems, use Uponor ProPEX LF brass copper press adapters.

Note: When transitioning from Uponor PEX to other piping materials, follow the appropriate installation instructions for that product.

Supporting Uponor PEX pipe

General notes

- Use copper tube size (CTS) clamps/supports
- Use clamps/supports designed for plastic pipe
- Follow local code requirements

Coiled piping

Refer to **Table 4** when supporting coiled PEX piping. Utilize the pipes natural flexibility to reduce fittings and connections for fixture runouts.



Figure 24: Supporting small-diameter coiled PEX

Table 4: Support requirements for coiled PEX pipe

Nominal pipe size	Maximum horizontal support spacing for coiled PEX pipe	
	International codes (IPC/IMC) and Uniform Codes (UPC/UMC)	National Plumbing Code of Canada (NPCC)
1" and smaller	2.67 ft. (32")	0.8m
1¼" and larger ¹	4 ft. (48")	0.8m

¹ Uponor recommends the use of PEX-a Pipe Support for systems with a Delta T (ΔT) greater than 40°F (22.2°C).

Supporting Uponor multiport tees

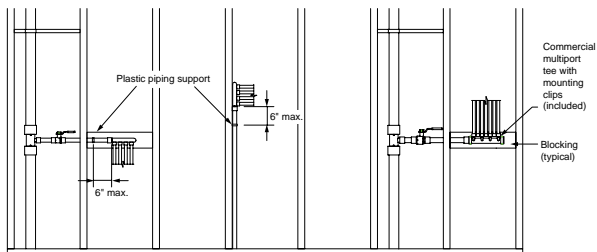

Figure 25: In-wall supports for multiport tees

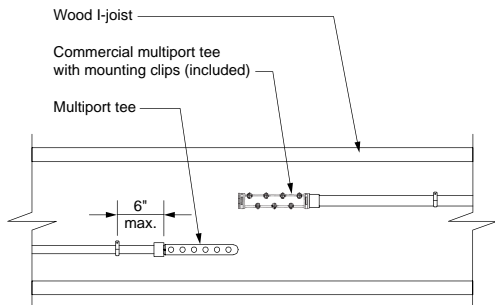

Figure 26: Supporting multiport tees on wood I-joists

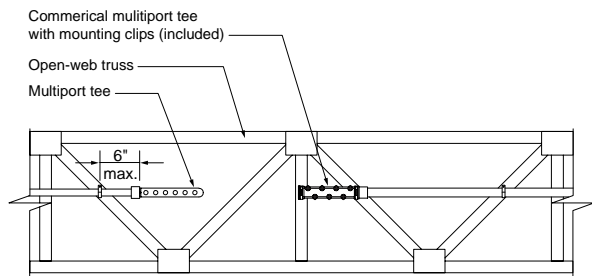

Figure 27: Supporting multiport tees on open-web wood trusses

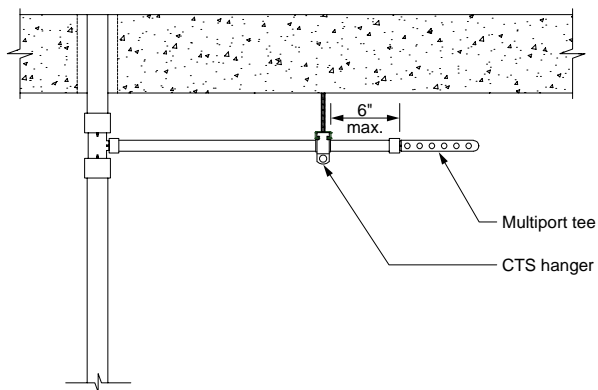

Figure 28: Supporting multiport tees in suspended applications

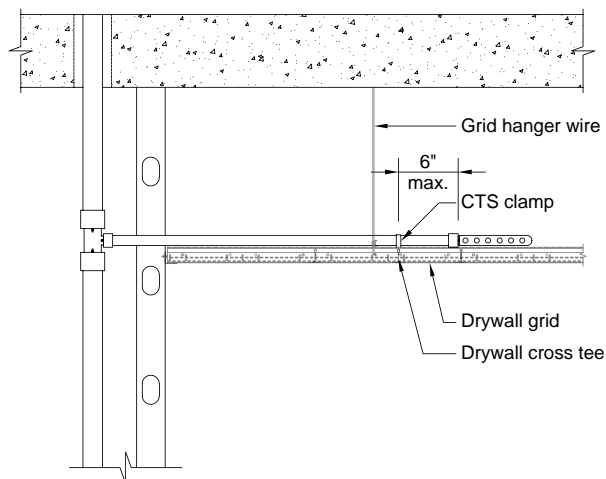

Figure 29: Supporting multiport tees on drywall grid

Strapping

Support Uponor PEX pipe by approved materials/methods only, including:

- Tube talons
- Clamps and hangers (i.e., loop or clevis hangers)
- Stand-off brackets

Isolate piping from other mechanical, electrical and plumbing (MEP) systems by means of insulation or stand-off brackets. Uponor does not recommend strapping PEX pipe directly to waste and vent piping. Always follow local code.



Figure 30: Proper bundling of Uponor PEX

Bundling

Parallel runs of Uponor PEX may be bundled together, when approved by local code, given the following:

- Bundle hot and cold water pipes separately at least 6" apart (15.2cm), unless piping is insulated.
- Support the bundle at the required on-center distance.
- Use cable ties to group a bundle.*

*Cable ties are not approved for supporting pipe.

Main/corridor straight-length piping

Per ICC-ES PMG 1006, using Uponor PEX-a Pipe Support allows extended support spacing up to 8 ft. (2.4m). Refer to **Table 5**.

Note: To minimize sagging and expansion/contraction, Uponor recommends using PEX-a Pipe Support for all main/corridor piping systems with ΔT s greater than 40°F (22.2°C).

Table 5: Horizontal support requirements with PEX-a Pipe Support

System type	Max. support spacing with PEX-a Pipe Support	Fixed points
ΔT less than or equal to 40°F (22.2°C) (e.g., domestic cold water, chilled water) ¹	8 ft. (2.4m)	Not required
ΔT greater than 40°F (22.2°C) (e.g., domestic hot water, domestic hot water recirculation, heating hot water) ¹	8 ft. (2.4m) with clamps every 32 ft. (9.7m) max. ²	See Table 6

¹These system examples are merely a suggestion of system types. The deciding factor is the temperature differential (Delta T) at the time of system start up.

²Fittings that are 1½" and smaller require support within 12" (0.3m) to prevent sagging. It is acceptable practice to support the fittings from their respective branch pipes.

Definitions

Use the below definitions with **Tables 5 and 6**.

Delta T (ΔT) – Difference between ambient air temperature and average system operating temperature.

Support – Loop, clevis, strut or similar that provide support for the piping system.

Clamps – Strut clamps or split-ring clamps that both support the piping system and limit its movement.

Fixed point – A support with clamps that is braced to the structure to prevent its movement due to expansion and/or contraction of the piping system. See **Figure 31**.



Figure 31: Supporting PEX with PEX-a Pipe Support

Expansion and contraction

To help minimize expansion and contraction in long, continuous piping runs with ΔT s greater than 40°F (22.2°C), use fixed points in conjunction with PEX-a Pipe Support and clamps. Refer to **Table 6** for requirements.

Table 6: Fixed-point requirements

Length of straight-piping run	# of fixed points*	Fixed-point spacing
0 – 63 ft. (0 – 19.2m)	0	N/A
64 – 128 ft. (19.5 – 39m)	1	Closest support with clamps to center
129 – 192 ft. (39.3 – 58.5m)	2	Min. 64 ft. apart (19.5m)
193 – 256 ft. (58.8 – 78m)	3	
257 – 320 ft. (78.3 – 97.5m)	4	

*Pipes 1" and smaller do not require fixed points.

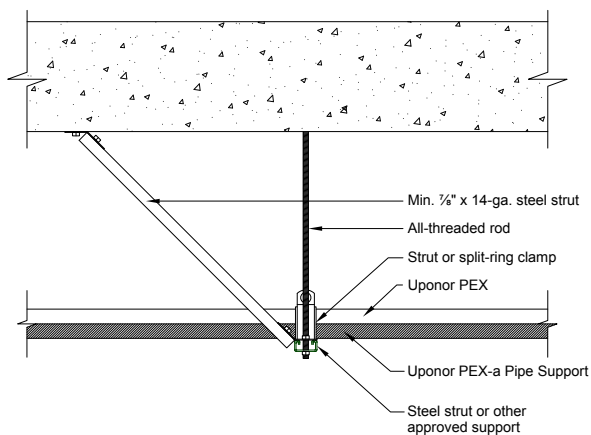

Figure 32: Fixed point

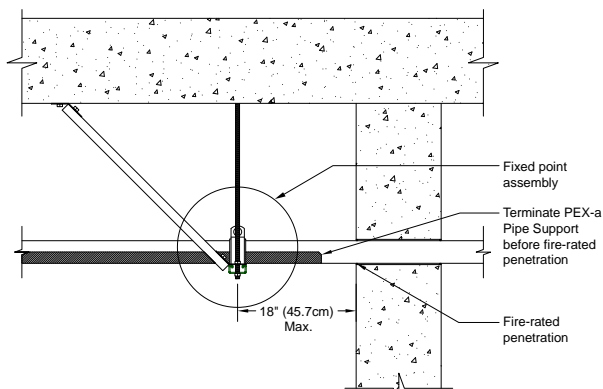

Figure 33: Fixed point near fire-penetration

Note: For 1¼" and larger PEX pipes with a ΔT greater than 40°F (22.2°C), install a fixed point within 18" (45.7cm) of a horizontal fire penetration.



Installing Uponor PEX-a Pipe Support

- Use full lengths and minimize cutting when possible.
- Deburr sharp edges if cutting is required.
- Maintain minimum distance to fittings according to **Table 7**.
- Secure included straps according to **Figures 35-38**.

Table 7: Minimum distance to fittings for PEX-a Pipe Support

Nominal pipe size	Distance to fitting "A"
½"	1¼" (32mm)
¾"	1¾" (44mm)
1"	2¼" (57mm)
1¼"	2¾" (70mm)
1½"	3" (76mm)
2"	4" (102mm)
2½"	5" (127mm)
3"	6" (152mm)

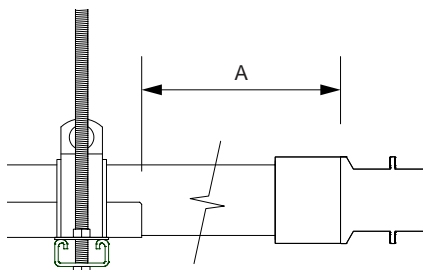

Figure 34: Minimum distance to fitting

Strapping PEX-a Pipe Support

Use the included stainless-steel straps to secure PEX-a Pipe Support to the PEX pipe. If the straps are misplaced, use a stainless-steel strap with a minimum 300-lb. rating that is also rated for the application (e.g., temperature, UV).

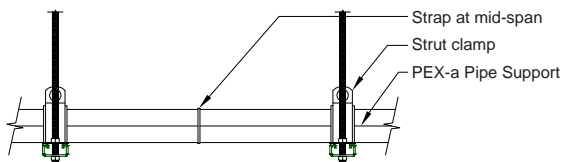

Figure 35: Strapping for systems using strut-type clamps or equivalent

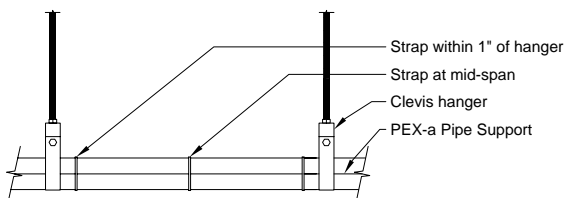

Figure 36: Strapping for systems using clevis or loop-type hangers or equivalent

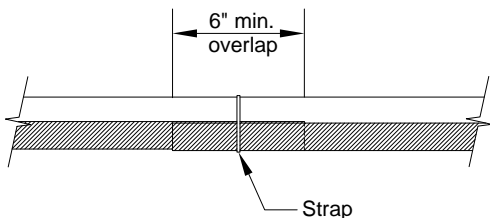

Figure 37: Strapping for overlaps

Fitting bridges

Use a fitting bridge to provide additional support to ½" to 1½" mid-span fittings. To create a fitting bridge, cut an oversized piece of PEX-a Pipe Support to the length shown in **Table 8** and strap using the included stainless-steel straps and

Table 8: Fitting bridge size and length

Nominal pipe/ fitting size	PEX-a Pipe Support size	PEX-a Pipe Support bridge minimum length
½"	1"	5½" (13.9cm)
¾"	1¼"	7½" (19cm)
1"	1½"	10½" (26.6cm)
1¼"	2"	12" (30.4cm)
1½"	2"	13½" (34.2cm)

Note: Fitting bridges are not required on 2" and larger pipe sizes.

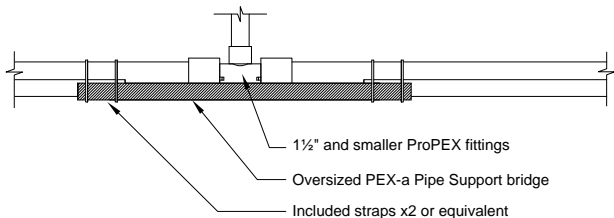

Figure 38: Fitting bridge

ASTM E84 requirements for PEX-a Pipe Support

Uponor PEX-a Pipe Support is tested and approved for use in ASTM E84 applications. To meet the requirements, install PEX-a Pipe Support per the following requirements:

- Cover pipe or fittings without PEX-a Pipe Support with a minimum ½" (13mm) thick rated insulation.
- There is no minimum segment length of PEX-a Pipe Support.

When installed per the above requirements, there are no spacing limitations between parallel piping runs.

Note: The above requirements also apply to PEX-a Pipe Support installed in a vertical position for ASTM E84 applications.

Note: Exposed sections of ½" and ¾" Uponor PEX pipe can be installed un-insulated if the pipe runs are separated by a minimum of 18" (45.7cm).

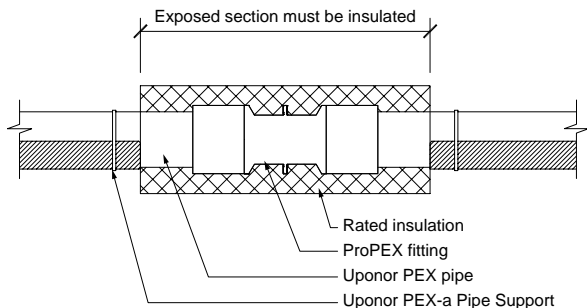

Figure 39: PEX-a Pipe Support installations in ASTM E84 applications

Supporting large-diameter valves

Table 9: Support requirements for large-diameter valves

Nominal pipe size	Valve-type	Maximum support distance "A"
1¼" - 2"	Ball	18" (45.7cm)
2½" - 3"	Butterfly	7" (17.7cm)

Note: For ball valves larger than 2", support within 7" (17.7cm).

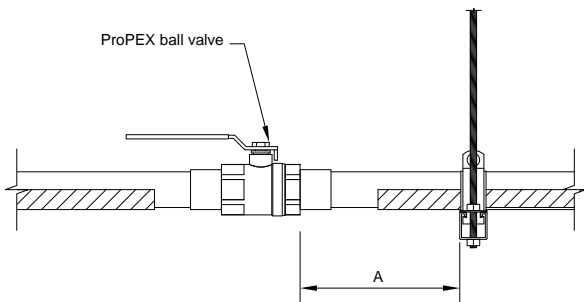

Figure 40: Supporting 1¼" to 2" ball valves

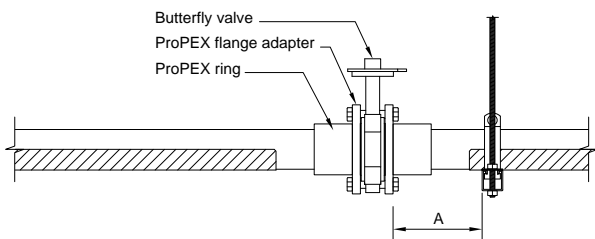

Figure 41: Supporting 2½" to 3" butterfly valves

Vertical support requirements

Vertical runs of pipe fall into two categories: in-wall and risers.

In-wall piping is typically smaller in diameter (<1"), and does not pass through multiple floors like a riser. It is most often the dedicated supply piping to the fixture.

Riser piping is typically larger in diameter (>1") and passes through multiple floors, often requiring fire-penetration sealants.

Note: The two categories above are not mutually exclusive. Use best judgement when determining which supports are necessary.

Table 10: Vertical support requirements for PEX pipe

		Nominal pipe size	All codes
In wall		All pipe sizes	5 ft. (1.5m)
Risers	Domestic cold water	All pipe sizes	Clamp at the base of each floor; clamp at top of every fourth floor; support every 5 ft. (1.5m)
	Domestic hot water	All pipe sizes	Clamp at base of each floor; clamp at top of every-other floor; support every 5 ft. (1.5m)
	Heating hot water; chilled water	All pipe sizes	Clamp at base of each floor; clamp at top of every floor; support every 5 ft. (1.5m)

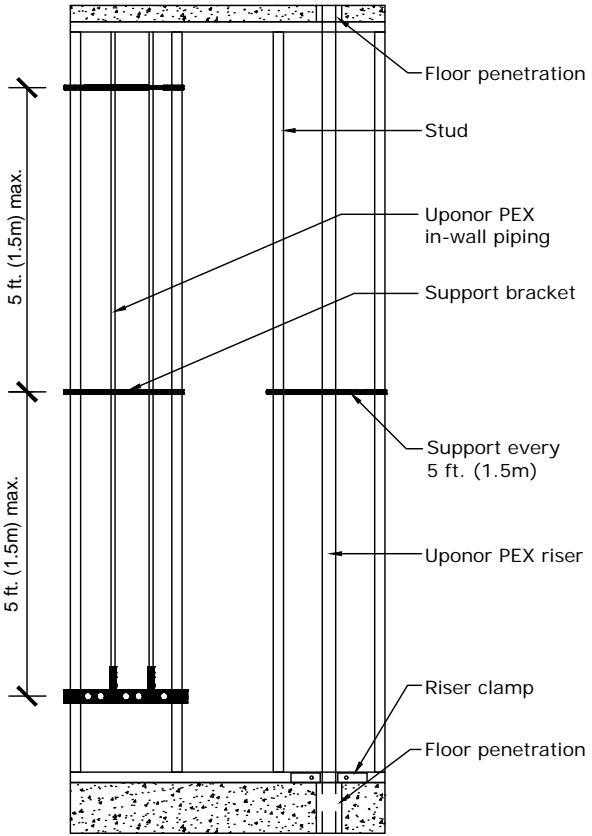

Figure 42: In-wall versus riser piping

Riser clamps

To prevent damage to ProPEX fittings, Uponor recommends the following minimum distances between riser clamps and ProPEX fittings.

Table 11: Distance to clamps

Nominal pipe size	2 x O.D.
½"	1¼" (32mm)
⅝"	1½" (38mm)
¾"	1¾" (44mm)
1"	2¼" (57mm)
1¼"	2¾" (70mm)
1½"	3¼" (83mm)
2"	4¼" (108mm)
2½"	4¾" (133mm)
3"	6¼" (159mm)
3½"	7¼" (184mm)
4"	8¼" (210mm)

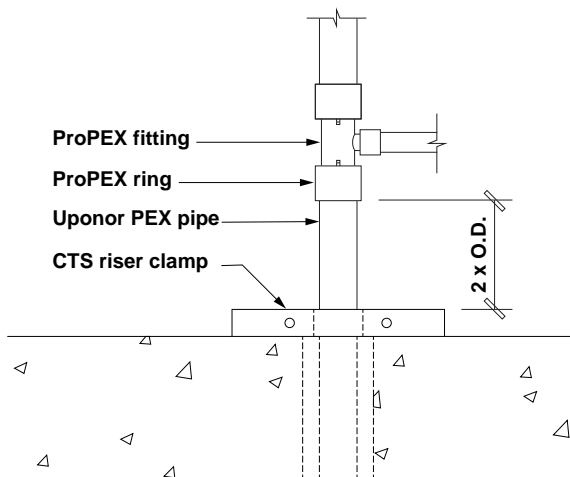
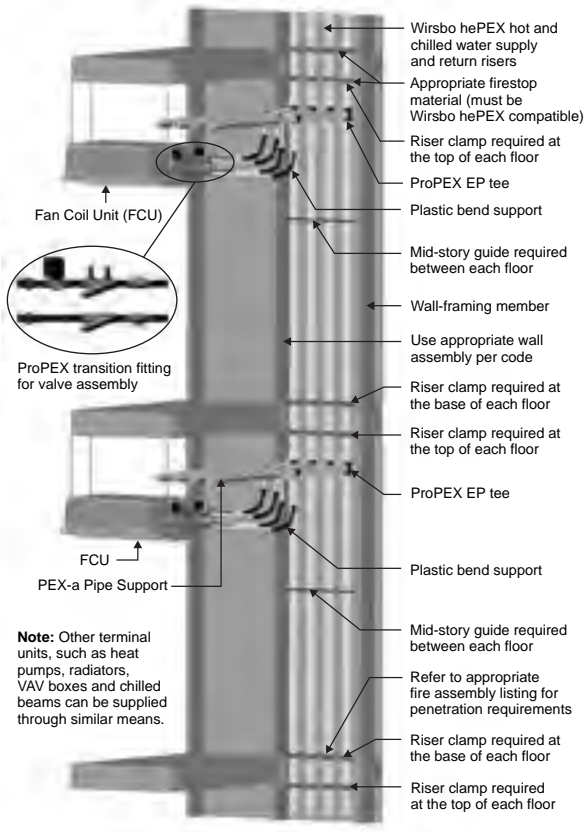

Figure 43: Riser clamp detail

Risers

Vertical piping runs must comply with support spacing as defined by code. Best practice is to use the floor/ceiling assembly as a fixed point for controlling expansion and contraction by means of riser clamps.



Note: Other terminal units, such as heat pumps, radiators, VAV boxes and chilled beams can be supplied through similar means.

Figure 44: Hydronic piping riser detail

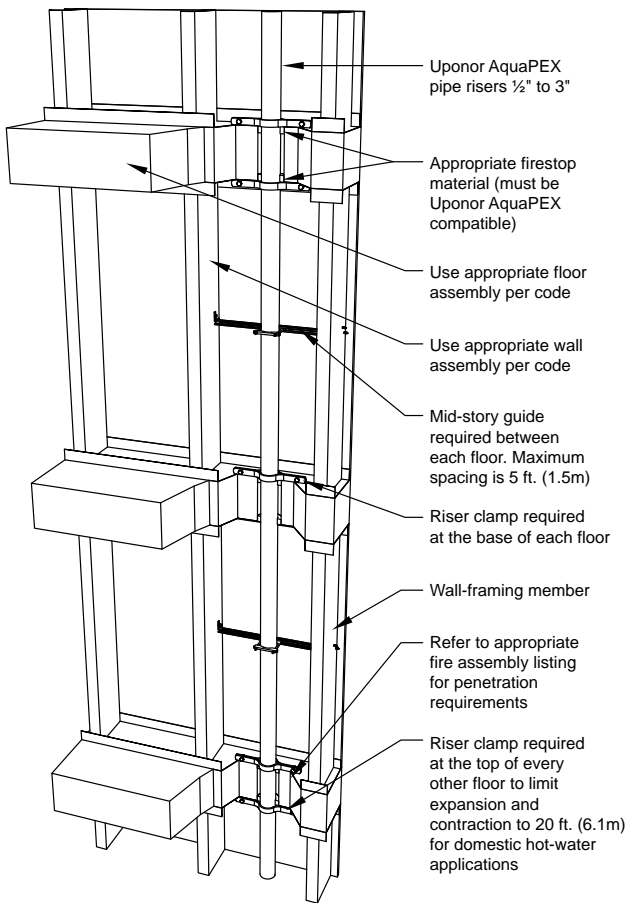

Figure 45: Domestic hot-water riser detail

Fire-resistant construction

The following requirements are for Uponor products installed in return-air plenum spaces.



United States — ASTM E84

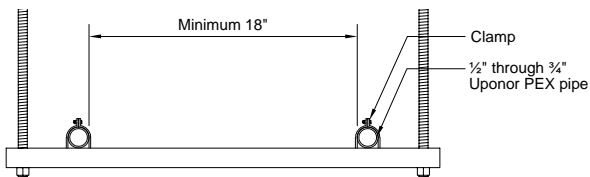

Figure 46: QAI P321-1

Guidelines: 1/2" through 3/4" (uninsulated)

Limitations: Adjacent runs shall be located at least 18" (45.7cm) apart.

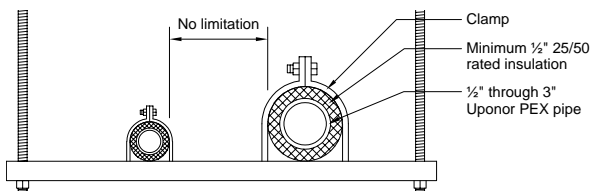

Figure 47: QAI P321-1

Guidelines: 1/2" through 3" (insulated)

Limitations: 1/2" minimum thickness insulation as specified in **Table 12**.

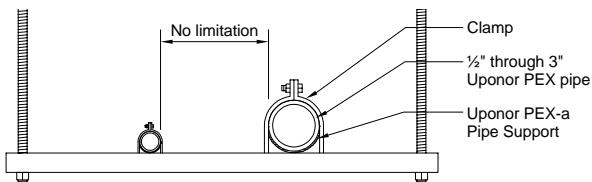

Figure 48: QAI P321-2

Guidelines: 1/2" through 3" (PEX-a Pipe Support)

Limitations: Pipe or fitting sections without PEX-a Pipe Support must be covered with a rated insulation per **Table 12**. There is no minimum length of PEX-a Pipe Support segments.



Canada — CAN/ULC-S102.2

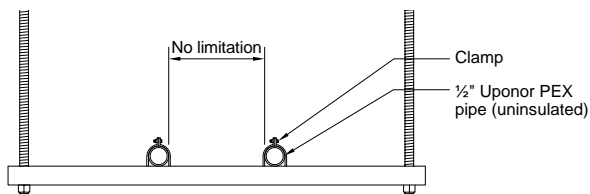

Figure 49: QAI P321-1

Guidelines: 1/2" (uninsulated)

Limitations: No spacing limitations.

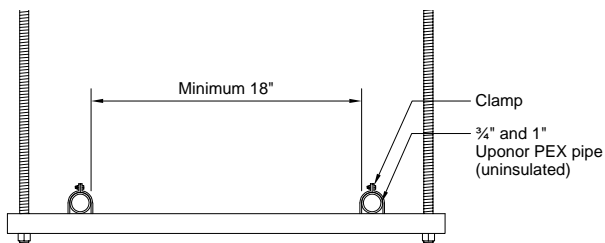

Figure 50: QAI P321-1

Guidelines: 3/4" and 1" (uninsulated)

Limitations: Adjacent pipe runs shall be located at least 18" (45.7cm) apart.

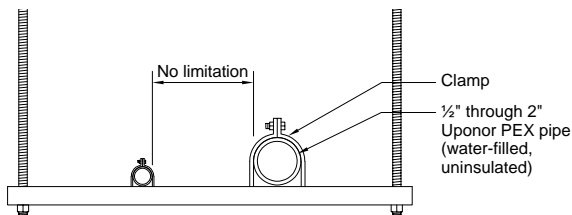

Figure 51: QAI P321-3

Guidelines: 1/2" through 2" (water-filled)

Limitations: No spacing limitations.



Canada — CAN/ULC-S102.2

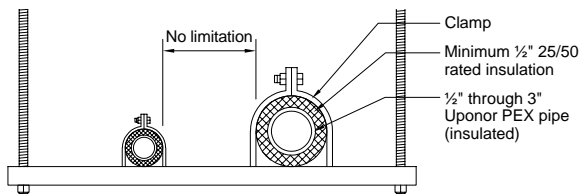

Figure 52: QAI P321-1

Guidelines: 1/2" through 3" (insulated)

Limitations: 1/2" minimum thickness insulation as specified in **Table 12**.

Table 12: Specifications for pipe insulations in ASTM E84 and CAN/ULC-S102.2 applications

Specifications for pipe insulations in ASTM E84 and CAN/ULC-S102.2 applications			
Products (minimum thickness)	ASTM E84 and CAN/ULC-S102.2		Density of insulation
	Flame spread	Smoke developed	
1/2" Manson Alley-K Fiberglass Pipe Insulation	25 or less	50 or less	4.0 pcf
1/2" Armaflex Composite Pipe Insulation	25 or less	50 or less	3.0 pcf
1/2" Johns Manville Micro-Lok Fiberglass Pipe Insulation	25 or less	50 or less	3.3 pcf
1/2" Johns Manville Micro-Lok HP	25 or less	50 or less	3.5 pcf
1/2" Owens Corning VaporWick Pipe Insulation	25 or less	50 or less	4.0 pcf
1/2" Owens Corning Fiberglass Pipe Insulation	25 or less	50 or less	3.5 pcf
1/2" Knauf Earthwool Redi-Klad Pipe Insulation	25 or less	50 or less	3.8 pcf
1/2" GLT Pipe and Tank Insulation	25 or less	50 or less	4.5 pcf
1/2" Nomalock Pipe Insulation*	25 or less	50 or less	4.0 pcf

*Check the rated grade of Nomalock insulations for plenum use.

ASTM E814 and CAN/ULC S115 listings

Table 13: Fire assemblies per manufacturer

Assembly types		Manufacturer			
		3M™		Hilti®	
		Wall	Floor/ceiling	Wall	Floor/ceiling
Wood-stud/steel-stud assemblies	1-hour	PHV-120-04	F-C-2039	W-L-2186	F-C-2081
		PHV-120-11	F-C-2240	W-L-2235	F-C-2230
		W-L-2091	F-C-2343	W-L-2466	F-C-2310
		W-L-2146	F-C-2344	W-L-2474	F-C-2334
		W-L-2173	F-C-2391	W-L-2480	F-C-8038
		W-L-2448	F-E-2002	W-L-2537	F-C-8044
		W-L-2483	F-E-2012	W-L-2467	
		W-L-2543	F-E-2040	W-L-5224	
		W-L-2547	PHV-120-04		
		W-L-2299	PHV-120-11		
		PV-60-02			

Note: This table is not meant to address every compatible fire assembly or firestop manufacturer approved and current for the specific application. Please refer to the respective manufacturer's website for more information.

■ = ASTM E814 and CAN/ULC S115 ■ = ASTM E814 only

Manufacturer			
RectorSeal®		STI	
Wall	Floor/ceiling	Wall	Floor/ceiling
W-L-2342	F-C-2298	F-C-2319	F-C-2032
W-L-2262	F-C-8015	W-L-2100	F-C-2252
W-L-2373	F-C-2329	W-L-2144	F-C-2319
W-L-2430	F-C-2212	W-L-2241	F-E-2003
W-L-2526	F-E-2007	W-L-2242	F-C-8021
W-L-2121	F-C-2221	W-L-2423	F-C-8029
W-L-2209	F-C-2385	W-L-2508	F-E-8003
W-L-2528		W-L-2548	F-C-8045
W-L-2402		W-L-2549	F-E-8010
W-L-2638		W-L-7193	
W-L-2639		F-C-8021	
W-L-2007		F-C-8029	
W-L-2170		W-L-5290	
W-L-2287		W-L-2631	
W-L-2457			
W-L-2524			
W-L-2594			
W-L-2595			

It is the end user's responsibility to ensure the fire assembly documentation being used is ebsite for detailed listing information.

■ = ASTM E814 and CAN/ULC S115 ■ = ASTM E814 only

ASTM E814 and CAN/ULC S115 listings

Table 14: Fire assemblies per manufacturer

Assembly types		Manufacturer			
		3M™		Hilti®	
		Wall	Floor/ceiling	Wall	Floor/ceiling
Wood-stud/steel-stud assemblies	2-hour	PHV-120-04	PHV-120-04	W-L-2186	F-C-2081
		PHV-120-11	PHV-120-11	W-L-2235	F-C-2310
		W-L-2090		W-L-2466	
		W-L-2091		W-L-2474	
		W-L-2146		W-L-2480	
		W-L-2448		W-L-2537	
		W-L-2483		W-L-2467	
		W-L-2543		W-L-5224	
		W-L-2547			
		W-L-2299			

Note: This table is not meant to address every compatible fire assembly or firestop manufacturer approved and current for the specific application. Please refer to the respective manufacturer's website for more information.

■ = ASTM E814 and CAN/ULC S115 ■ = ASTM E814 only

RectorSeal®		STI	
Wall	Floor/ceiling	Wall	Floor/ceiling
W-L-2342	F-C-2221	W-L-2100	
W-L-2262	F-C-2385	W-L-2144	
W-L-2373		W-L-2241	
W-L-2430		W-L-2242	
W-L-2526		W-L-2423	
W-L-2121		W-L-2508	
W-L-2209		W-L-2548	
W-L-2528		W-L-2549	
W-L-2402		W-L-7193	
W-L-2638		W-L-5290	
W-L-2639		W-L-2631	
W-L-2170			
W-L-2287			
W-L-2457			
W-L-2524			
W-L-2594			
W-L-2595			

It is the end user's responsibility to ensure the fire assembly documentation being used is the most current for detailed listing information.

■ = ASTM E814 and CAN/ULC S115 ■ = ASTM E814 only

RectorSeal®		STI		HOLDRITE
Wall	Floor/ceiling	Wall	Floor/ceiling	Floor/ceiling
W-J-2162	C-AJ-2628	W-J-2021	C-AJ-2031	F-A-2188
W-J-2122	F-A-2171	W-J-2043	C-AJ-2140	F-A-2221
W-J-2180	C-AJ-2701	W-J-2076	C-AJ-2291	F-B-2042
W-J-2025	C-AJ-2176	W-J-2077	F-A-2186	F-A-2269
C-AJ-2628	F-A-2235	W-J-2232	F-A-2224	F-A-2222
C-AJ-2679	F-A-2237	W-J-2233	F-A-2225	F-A-2037
C-AJ-2701	C-AJ-2494	W-J-5148	C-AJ-2586	
W-J-2295	C-AJ-2679	C-AJ-2586	C-AJ-5345	
W-J-2296	C-AJ-2702	C-AJ-5345	C-BJ-2046	
C-AJ-2702		C-BJ-2046		
C-AJ-2176		W-J-2291		
C-AJ-2494				
W-J-2035				
W-J-2051				
W-J-2142				
W-J-2197				
W-J-2220				
W-J-2222				
W-J-2224				
W-J-2266				
C-AJ-2119	C-AJ-2119	C-AJ-2671	C-AJ-2671	F-A-2176
C-AJ-2194	C-AJ-2194	C-AJ-5344	C-AJ-5344	F-A-2221
C-AJ-2622	C-AJ-2622	C-AJ-5346	C-AJ-5346	F-B-2042
			C-AJ-2578	F-A-2269
			F-A-2203	F-A-8034
			F-A-2204	F-A-2222

It is the end user's responsibility to ensure the fire assembly documentation being used is the most current version available on the website for detailed listing information.

■ = ASTM E814 and CAN/ULC S115 □ = ASTM E814 only

Below-grade installation

Uponor PEX piping and ProPEX fittings (EP and LF brass) are all approved for burial directly in soil. Refer to **Figures 53** and **54** for proper trench preparation. Always follow local code when burying Uponor PEX pipe as some jurisdictions require additional sleeving and protection.

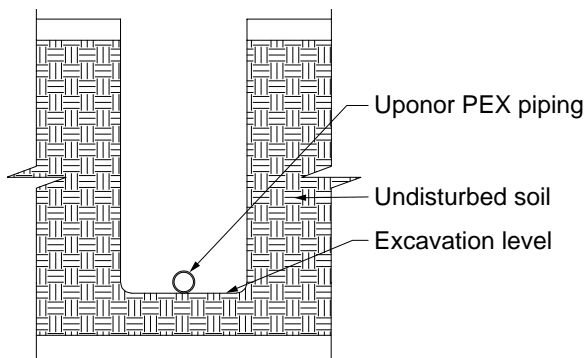

Figure 53: Good soil conditions

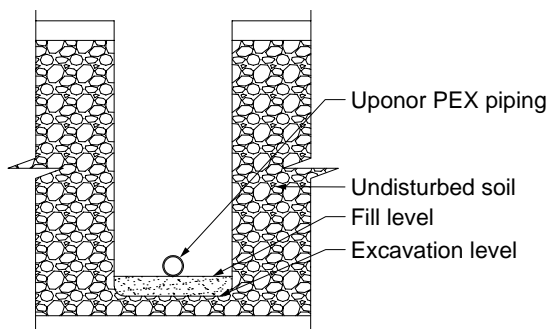

Figure 54: Poor soil conditions

Horizontal directional drilling (HDD)

Uponor PEX HDD requirements:

- Up to 600 ft. (182m) in length
- Depths up to 15 ft. (4.5m)

PEX pipe must:

- Be the follow pipe
- Not contact any sharp objects
- Be pressure tested after installation

Table 16: Safe pull force

SDR9 PEX-a 12-hour pull		
Nominal pipe size	Tensile yield design (safety) factor	Allowable tensile load at 73°F (22.8°C) lbs. (N)
½"	0.4	128 (569)
¾"	0.4	248 (1,103)
1"	0.4	411 (1,828)
1¼"	0.4	615 (2,735)
1½"	0.4	859 (3,821)
2"	0.4	1,465 (6,516)
2½"	0.4	2,239 (9,960)
3"	0.4	3,169 (14,096)

In-slab installation

Uponor PEX piping and ProPEX EP and brass fittings are approved for embedment in concrete. Always follow local code when embedding Uponor PEX pipe as some jurisdictions require additional sleeving and protection. Uponor recommends using Pre-sleeved Uponor AquaPEX pipe for embedment in concrete when additional protection is required.

Note: Cover brass fittings with a protective material, such as 6-mil poly wrap, and secure with cable ties.



Figure 55: In-slab installation

Pressure testing

Residential applications

1. Pressurize system to 25 psi (1.7 bar) above working pressure or 100 psi (6.9 bar).
2. Test in accordance with local code.

Commercial applications

1. Visually confirm all connections are properly made per Uponor installation guidelines.
2. Ensure that all components, fixtures and equipment not rated for the test pressure are isolated from the test system.
3. Ensure that all other thermoplastic piping materials are isolated from the test system.
4. Fill the system with potable water, air or a mixture of both.
5. Condition the system to 1.5 times the required test pressure for 30 minutes. This will require constant pumping or cycling the valve and compressor to maintain a pressure of 1.5 times the test pressure. If cycling the valve and compressor, apply additional pressure once the psi has dropped 10 psi (0.7 bar).
6. After conditioning the system for 30 minutes, quickly relieve excess pressure by opening the valve. Close the valve when the system has reached the desired test pressure.

Note: Uponor recommends a test pressure of 80 psi (5.5 bar) (unless local code dictates higher pressures).

7. Once the valve is closed, confirm a slight rise in pressure 3 to 6 psi (0.2 to 0.4 bar). This increase will occur as the pipe's I.D. is shrinking from its conditioned state to equalize at the lower pressure.
8. Visually check for leakage and monitor the pressure for the duration specified by local code. (A typical pressure test can range from 2 to 24 hours).
9. If there is no reduction in pressure, the system is regarded as leak tight.

Note: Slight fluctuations of pressure are normal due to ambient temperature changes, especially during long durations (e.g., 24 hours).

10. Flush the system as required by code.

Note: If using water to pressure test the system, purge all water from the system prior to the ambient air temperatures falling to 32°F (0°C). Failing to remove the water from the system can result in damage to the piping and associated equipment.

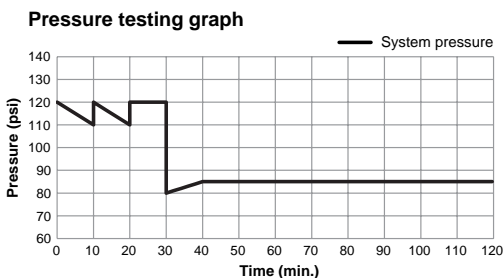

Figure 56: Pressure testing graph

Water system disinfection

Uponor recommends flushing an AquaPEX plumbing system with clean, potable water. When system disinfection is required, Uponor AquaPEX piping should be disinfected in accordance with AWWA C651, Standard for Disinfecting Water Mains, or local codes.

Note: To prevent reduced service life of system components, disinfection solutions should not remain in the system longer than 24 hours. Flush the system with potable water after disinfection.

Use a chlorine solution of 50 parts per million (ppm) for 24 hours or 200 ppm for three hours for disinfection.

Appendix A: Dimensions and physical characteristics of Uponor PEX pipe

Table A-1: Dimensions and physical characteristics of SDR9 Uponor PEX pipe

Dimensions and physical characteristics of SDR9 Uponor PEX pipe						
Nominal pipe size	Pipe O.D. (in)	Pipe I.D. (in)	Weight of pipe only lbs/ft (kg/m)	Contents of pipe gal/ft (l/m)	Weight of pipe and water lbs/ft (kg/m)	
1/4"	0.375	0.241	0.04 (0.018)	0.0024 (0.009)	0.06 (0.027)	
3/8"	0.50	0.35	0.05 (0.022)	0.005 (0.018)	0.09 (0.040)	
1/2"	0.625	0.475	0.06 (0.027)	0.0092 (0.034)	0.14 (0.063)	
5/8"	0.750	0.574	0.08 (0.036)	0.0134 (0.050)	0.19 (0.086)	
3/4"	0.875	0.671	0.1 (0.045)	0.0184 (0.069)	0.25 (0.113)	
1"	1.125	0.862	0.2 (0.090)	0.0303 (0.114)	0.45 (0.204)	
1 1/4"	1.375	1.054	0.34 (0.154)	0.0453 (0.171)	0.72 (0.326)	
1 1/2"	1.625	1.244	0.44 (0.199)	0.0632 (0.239)	0.96 (0.435)	
2"	2.125	1.629	0.682 (0.309)	0.1083 (0.409)	1.58 (0.716)	
2 1/2"	2.625	2.011	0.93 (0.421)	0.1649 (0.624)	2.3 (1.043)	
3"	3.125	2.4	1.28 (0.580)	0.2351 (0.889)	3.24 (1.469)	

Appendix B: Hydrostatic temperature and pressure ratings

Uponor maintains standard-grade ratings for Uponor PEX piping. Uponor PEX carries the following temperature and pressure ratings shown in **Table B-1**.

Note: Uponor EP and LF brass fittings carry the same temperature and pressure ratings as Uponor PEX pipe.

Table B-1: Hydrostatic temperature and pressure ratings for Uponor PEX pipe

ASTM F876 temperature and pressure ratings for SDR9 PEX		
Rated temperature	Hydrostatic design stress (HDS) psi	Pressure rating for water psi
73.4°F/23°C	630	160 psi (11 bar)
180°F/82°C	400	100 psi (6.9 bar)
200°F/93°C	315	80 psi (5.5 bar)

Interpolation method

Pressure ratings at different temperatures are determined by using a linear relationship between the standard-grade ratings. See **Table B-2** for interpolated temperature and pressure ratings.

Excessive temperature and pressure capability

In accordance with ASTM F876 Standard Specification for Crosslinked Polyethylene (PEX) Piping, the excessive temperature and pressure capability of Uponor PEX is 210°F at 150 psi (99°C at 10 bar).

This standard requires that Uponor PEX piping maintain its integrity for a period of 720 hours (30 days) at 210°F (99°C) at 150 psi (10 bar). If installed as directed, Uponor PEX will withstand these conditions.

Note: Excessive temperature and pressure requirements are always subject to approval by local building codes (e.g., temperature and pressure-relief valves).

Table B-2: Interpolated hydrostatic temperature and pressure ratings for Uponor PEX pipe

Interpolated hydrostatic temperature and pressure ratings	
°F/°C	PSI/bar
200.0/93.3	80/5.5
190.0/87.8	90/6.2
180.0/82.2	100/6.9
170.0/76.7	106/7.3
160.0/71.1	111/7.7
150.0/65.6	117/8.0
140.0/60.0	123/8.5
130.0/54.4	128/8.8
120.0/48.9	134/9.2
110.0/43.3	139/9.6
100.0/37.8	145/10.0
90.0/32.2	151/10.4
80.0/26.7	156/10.8
73.4/23.0	160/11.0
60.0/15.6	168/11.6
50.0/10.0	173/11.9
40.0/4.4	179/12.3

Appendix C: ProPEX fitting dimensions

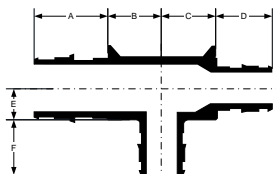

ProPEX EP reducing tees		A	B	C	D	E	F
Description	Part no.	in	in	in	in	in	in
		mm	mm	mm	mm	mm	mm
1/2" PEX x 1/2" PEX x 3/4" PEX	Q4755575	3/4	11/16	11/16	3/4	1/2	15/16
3/4" PEX x 1/2" PEX x 1/2" PEX	Q4757555	15/16	11/16	11/16	3/4	1/2	3/4
3/4" PEX x 1/2" PEX x 3/4" PEX	Q4757557	15/16	11/16	11/16	3/4	1/2	15/16
3/4" PEX x 3/4" PEX x 5/8" PEX	Q4757563	15/16	11/16	11/16	15/16	9/16	7/8
3/4" PEX x 3/4" PEX x 1/2" PEX	Q4757550	15/16	11/16	11/16	15/16	9/16	3/4
3/4" PEX x 3/4" PEX x 1" PEX	Q4757710	15/16	7/8	7/8	15/16	11/16	13/16
1" PEX x 3/4" PEX x 3/4" PEX	Q4751775	13/16	7/8	7/8	15/16	11/16	15/16
1" PEX x 3/4" PEX x 1" PEX	Q4751751	13/16	7/8	7/8	15/16	11/16	13/16
1" PEX x 1" PEX x 1/2" PEX	Q4751150	13/16	7/8	7/8	13/16	11/16	3/4
1" PEX x 1" PEX x 3/4" PEX	Q4751175	13/16	7/8	7/8	13/16	11/16	15/16
1 1/4" PEX x 1" PEX x 3/4" PEX	Q4751317	13/16	15/16	15/16	17/16	15/16	15/16
1 1/4" PEX x 1" PEX x 1" PEX	Q4751311	17/16	15/16	15/16	13/16	15/16	13/16
1 1/4" PEX x 1 1/4" PEX x 1/2" PEX	Q4751350	17/16	3/4	3/4	17/16	3/4	3/4
1 1/4" PEX x 1 1/4" PEX x 3/4" PEX	Q4751337	17/16	7/8	7/8	17/16	3/4	15/16
1 1/4" PEX x 1 1/4" PEX x 1" PEX	Q4751331	17/16	15/16	15/16	17/16	15/16	13/16
1 1/2" PEX x 1" PEX x 3/4" PEX	Q4751517	1 11/16	13/16	13/16	13/16	1 1/8	15/16
1 1/2" PEX x 1" PEX x 1" PEX	Q4751511	1 11/16	13/16	13/16	13/16	1 1/8	13/16
1 1/2" PEX x 1" PEX x 1 1/2" PEX	Q4751505	1 11/16	1 1/4	1 1/4	13/16	15/16	1 1/16
		43	32	32	30	24	43

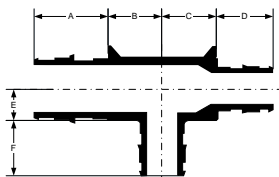

ProPEX EP reducing tees		A	B	C	D	E	F
Description	Part no.	in	in	in	in	in	in
		mm	mm	mm	mm	mm	mm
1½" PEX x ¼" PEX x ¾" PEX	Q4751537	1 ¹¹ / ₁₆	1 ¹ / ₈	1 ¹ / ₈	1 ⁷ / ₁₆	7 ⁷ / ₈	1 ⁵ / ₁₆
		43	29	29	37	23	24
1½" PEX x ¼" PEX x 1" PEX	Q4751531	1 ¹¹ / ₁₆	1 ¹ / ₈	1 ¹ / ₈	1 ⁷ / ₁₆	7 ⁷ / ₈	1 ³ / ₁₆
		43	29	29	37	23	30
1½" PEX x ¼" PEX x ¼" PEX	Q4751533	1 ¹¹ / ₁₆	1 ¹ / ₈	1 ¹ / ₈	1 ⁷ / ₁₆	7 ⁷ / ₈	1 ⁷ / ₁₆
		43	29	29	37	23	37
1½" PEX x ½" PEX x ½" PEX	Q4751550	1 ¹¹ / ₁₆	¾	¾	1 ¹¹ / ₁₆	1 ⁹ / ₁₆	¾
		43	19	19	43	21	19
1½" PEX x ½" PEX x ¾" PEX	Q4751557	1 ¹¹ / ₁₆	1 ³ / ₁₆	1 ³ / ₁₆	1 ¹¹ / ₁₆	1 ¹ / ₈	1 ⁵ / ₁₆
		43	30	30	43	28	24
1½" PEX x ½" PEX x 1" PEX	Q4751551	1 ¹¹ / ₁₆	1 ³ / ₁₆	1 ³ / ₁₆	1 ¹¹ / ₁₆	1 ¹ / ₈	1 ³ / ₁₆
		43	30	30	43	28	30
1½" PEX x ½" PEX x ¼" PEX	Q4751553	1 ¹¹ / ₁₆	1 ³ / ₁₆	1 ³ / ₁₆	1 ¹¹ / ₁₆	1 ¹ / ₈	1 ⁷ / ₁₆
		43	30	30	43	28	37
2" PEX x 1½" PEX x ¾" PEX	Q4752575	2 ³ / ₁₆	1 ⁵ / ₁₆	1 ¹ / ₁₆	1 ¹¹ / ₁₆	1 ⁵ / ₁₆	1 ⁵ / ₁₆
		56	34	34	43	33	24
2" PEX x 1½" PEX x 1" PEX	Q4752051	2 ³ / ₁₆	1 ⁵ / ₁₆	1 ¹ / ₁₆	1 ¹¹ / ₁₆	1 ⁵ / ₁₆	1 ³ / ₁₆
		56	34	34	43	33	30
2" PEX x 1½" PEX x ¼" PEX	Q4752053	2 ³ / ₁₆	1 ³ / ₈	1 ³ / ₈	1 ¹¹ / ₁₆	1 ⁵ / ₁₆	1 ⁷ / ₁₆
		56	35	35	43	33	37
2" PEX x 1½" PEX x ½" PEX	Q4752055	2 ³ / ₁₆	1 ³ / ₈	1 ³ / ₈	1 ¹¹ / ₁₆	1 ⁵ / ₁₆	1 ¹¹ / ₁₆
		56	35	35	43	33	43
2" PEX x 1½" PEX x 2" PEX	Q4752152	2 ³ / ₁₆	1 ³ / ₄	1 ³ / ₄	1 ¹¹ / ₁₆	1 ¹ / ₁₆	2 ³ / ₁₆
		56	44	44	43	26	56
2" PEX x 2" PEX x ½" PEX	Q4752250	2 ³ / ₁₆	¾	¾	2 ³ / ₁₆	1 ¹ / ₁₆	¾
		56	19	19	56	26	19
2" PEX x 2" PEX x ¾" PEX	Q4752275	2 ³ / ₁₆	1 ⁵ / ₁₆	1 ⁵ / ₁₆	2 ³ / ₁₆	1 ⁵ / ₁₆	1 ⁵ / ₁₆
		56	34	34	56	33	24
2" PEX x 2" PEX x 1" PEX	Q4752210	2 ³ / ₁₆	1 ⁵ / ₁₆	1 ⁵ / ₁₆	2 ³ / ₁₆	1 ⁵ / ₁₆	1 ³ / ₁₆
		56	34	34	56	33	30
2" PEX x 2" PEX x ¼" PEX	Q4752213	2 ³ / ₁₆	1 ⁵ / ₁₆	1 ⁵ / ₁₆	2 ³ / ₁₆	1 ⁵ / ₁₆	1 ⁷ / ₁₆
		56	34	34	56	33	37
2" PEX x 2" PEX x ½" PEX	Q4752215	2 ³ / ₁₆	1 ⁵ / ₁₆	1 ⁵ / ₁₆	2 ³ / ₁₆	1 ⁵ / ₁₆	1 ¹¹ / ₁₆
		56	34	34	56	33	43

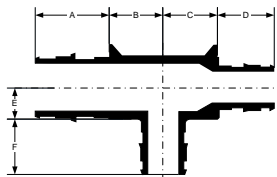

ProPEX EP reducing tees		A	B	C	D	E	F
Description	Part no.	in	in	in	in	in	in
		mm	mm	mm	mm	mm	mm
2½" PEX x 2" PEX x 1½" PEX	Q4752525	2 ¹³ / ₁₆	1 ⁵ / ₈	1 ⁵ / ₈	2 ⁹ / ₁₆	1 ⁵ / ₁₆	1 ¹ / ₄
		72	41	41	56	33	43
2½" PEX x 2" PEX x 2" PEX	Q4752522	2 ¹³ / ₁₆	2	2	2 ⁹ / ₁₆	1 ⁵ / ₁₆	2 ⁹ / ₁₆
		72	51	51	56	33	56
2½" PEX x 2½" PEX x ¾" PEX	Q4752557	2 ¹³ / ₁₆	1 ⁵ / ₈	1 ⁵ / ₈	2 ¹⁹ / ₁₆	1 ⁵ / ₁₆	1 ⁵ / ₁₆
		72	29	29	72	33	24
2½" PEX x 2½" PEX x 1" PEX	Q4752510	2 ¹³ / ₁₆	1¼	1¼	2 ¹⁹ / ₁₆	1 ⁵ / ₁₆	1 ⁹ / ₁₆
		72	32	32	72	33	30
2½" PEX x 2½" PEX x 1¼" PEX	Q4752513	2 ¹³ / ₁₆	1½	1½	2 ¹⁹ / ₁₆	1 ⁵ / ₁₆	1 ⁷ / ₁₆
		72	38	38	72	33	37
2½" PEX x 2½" PEX x 1½" PEX	Q4752515	2 ¹³ / ₁₆	1 ⁵ / ₈	1 ⁵ / ₈	2 ¹³ / ₁₆	1 ⁵ / ₁₆	1 ¹ / ₁₆
		72	41	41	72	33	43
2½" PEX x 2½" PEX x 2" PEX	Q4752520	2 ¹³ / ₁₆	2	2	2 ¹³ / ₁₆	1¼	2 ⁹ / ₁₆
		72	51	51	72	32	56
3" PEX x 2" PEX x 2" PEX	Q4753220	3 ³ / ₈	2	2	2 ⁹ / ₁₆	1 ⁹ / ₁₆	2 ⁹ / ₁₆
		86	51	51	56	39	56
3" PEX x 2½" PEX x 1½" PEX	Q4753215	3 ³ / ₈	1 ⁵ / ₈	1 ⁵ / ₈	2 ¹⁹ / ₁₆	1 ⁹ / ₁₆	1 ¹ / ₁₆
		86	41	41	72	39	43
3" PEX x 2½" PEX x 2" PEX	Q4753252	3 ³ / ₈	2	2	2 ¹⁹ / ₁₆	1 ⁹ / ₁₆	2 ⁹ / ₁₆
		86	51	51	72	39	56
3" PEX x 3" PEX x ¾" PEX	Q4753375	3 ³ / ₈	1 ⁵ / ₈	1 ⁵ / ₈	3 ³ / ₈	1 ⁹ / ₁₆	1 ⁵ / ₁₆
		86	29	29	86	39	24
3" PEX x 3" PEX x 1" PEX	Q4753310	3 ³ / ₈	1¼	1¼	3 ³ / ₈	1 ⁹ / ₁₆	1 ⁹ / ₁₆
		86	32	32	86	39	30
3" PEX x 3" PEX x 1¼" PEX	Q4753313	3 ³ / ₈	1½	1½	3 ³ / ₈	1 ⁹ / ₁₆	1 ⁷ / ₁₆
		86	38	38	86	39	37
3" PEX x 3" PEX x 1½" PEX	Q4753315	3 ³ / ₈	1 ⁵ / ₈	1 ⁵ / ₈	3 ³ / ₈	1 ⁹ / ₁₆	1 ¹ / ₁₆
		86	41	41	86	39	43
3" PEX x 3" PEX x 2" PEX	Q4753320	3 ³ / ₈	2	2	3 ³ / ₈	1 ⁹ / ₁₆	2 ⁹ / ₁₆
		86	51	51	86	39	72
3" PEX x 3" PEX x 2½" PEX	Q4753325	3 ³ / ₈	2½	2½	3 ³ / ₈	1 ⁹ / ₁₆	2 ⁹ / ₁₆
		86	64	64	86	39	72

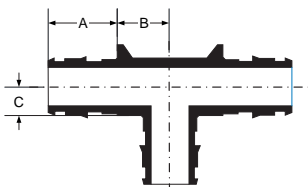

ProPEX tees		A	B	C
Description	Part no.	in	in	in
		mm	mm	mm
1/2" PEX x 1/2" PEX x 1/2" PEX	Q4755050	3/4	9/16	3/8
		19	15	10
1/2" PEX x 1/2" PEX x 1/2" PEX	LF4705050	11/16	9/16	5/16
		18	14	8
3/4" PEX x 3/4" PEX x 3/4" PEX	Q4757575	15/16	11/16	1/2
		24	18	13
3/4" PEX x 3/4" PEX x 3/4" PEX	LF4707575	15/16	11/16	3/8
		24	18	10
1" PEX x 1" PEX x 1" PEX	Q4751010	13/16	7/8	11/16
		30	22	18
1" PEX x 1" PEX x 1" PEX	LF4701010	13/16	7/8	9/16
		30	22	14
1 1/4" PEX x 1 1/4" PEX x 1 1/4" PEX	Q4751313	17/16	15/16	15/16
		37	25	24
1 1/2" PEX x 1 1/2" PEX x 1 1/2" PEX	Q4751515	1 11/16	1 3/16	1 1/8
		43	30	28
2" PEX x 2" PEX x 2" PEX	Q4752000	2 3/16	1 9/16	1 5/8
		56	40	41
2 1/2" PEX x 2 1/2" PEX x 2 1/2" PEX	Q4752500	2 13/16	2 7/16	1 5/16
		72	62	34
3" PEX x 3" PEX x 3" PEX	Q4753000	3 3/8	2 3/4	1 7/16
		86	70	37

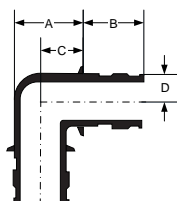

EP elbow

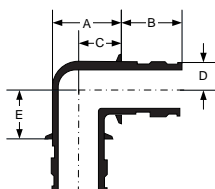

Brass elbow

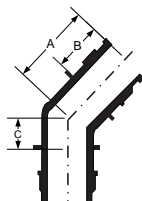

EP elbow

ProPEX elbows		A	B	C	D	E
Description	Part no.	in	in	in	in	in
		mm	mm	mm	mm	mm
1/2" PEX x 1/2" PEX EP Elbow	Q4760500	1 1/16	3/4	9/16	1/4	
3/4" PEX x 3/4" PEX EP Elbow	Q4760750	1 1/16	15/16	11/16	3/8	
3/4" PEX x 3/4" PEX Brass Elbow	LF4710750	1 1/16	15/16	11/16	3/8	3/8
1" PEX x 1" PEX EP Elbow	Q4761000	1 5/8	1 3/16	7/8	13/16	
1" PEX x 1" PEX Brass Elbow	LF4711000	1 1/4	1 3/16	7/8	13/16	9/16
1 1/4" PEX x 1 1/4" PEX EP Elbow	Q4761250	1 3/4	1 1/16	1 1/8	5/8	
1 1/2" PEX x 1 1/2" PEX EP Elbow	Q4761500	1 7/8	1 11/16	1 3/16	1 1/16	
1 1/2" PEX x 1 1/2" PEX 45 Elbow	Q4761515	2 5/16	1 11/16	5/8		
2" PEX x 2" PEX EP Elbow	Q4762000	2 9/16	2 3/16	1 5/8	1 5/16	
2" PEX x 2" PEX 45 Elbow	Q4762020	2 15/16	2 3/16	3/4		
2 1/2" PEX x 2 1/2" PEX EP Elbow	Q4762500	3 5/16	2 13/16	2 1/8	1 3/16	
2 1/2" PEX x 2 1/2" PEX 45 Elbow	Q4762525	3 13/16	2 13/16	1		
3" PEX x 3" PEX EP Elbow	Q4763000	3 15/16	3 3/8	2 1/2	1 7/16	
3" PEX x 3" PEX 45 Elbow	Q4763030	4 1/2	3 3/8	1 1/8		

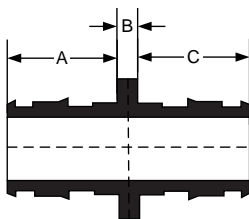

ProPEX couplings		A	B	C
Description	Part no.	in	in	in
		mm	mm	mm
1/2" PEX x 1/2" PEX	Q4775050	3/4 19	1/8 3	3/4 19
	LF4545050	11/16 18	1/8 3	11/16 18
3/4" PEX x 3/4" PEX	Q4777575	15/16 24	1/8 3	15/16 24
	LF4547575	15/16 24	1/8 3	15/16 24
1" PEX x 1" PEX	Q4771010	1 3/16 30	1/8 3	1 3/16 30
	LF4541010	1 3/16 30	1/8 3	1 3/16 30
1 1/4" PEX x 1 1/4" PEX	Q4771313	1 7/16 37	1/8 3	1 7/16 37
1 1/2" PEX x 1 1/2" PEX	Q4771515	1 11/16 44	1/8 3	1 11/16 44
2" PEX x 2" PEX	Q4772020	2 3/16 56	1/4 6	2 3/16 56
	Q4772525	2 13/16 72	1/4 6	2 13/16 72
3" PEX x 3" PEX	Q4773030	3 3/8 86	1/4 6	3 3/8 86

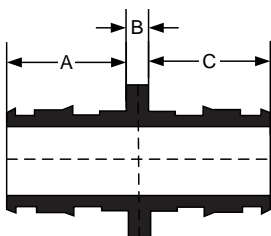

ProPEX reducing couplings		A	B	C
Description	Part no.	in	in	in
		mm	mm	mm
3/4" PEX x 1/2" PEX	Q4775075	15/16	1/8	3/4
		24	3	19
1" PEX x 3/4" PEX	Q4777510	1 3/16	1/8	15/16
	LF4547510	30	3	24
1 1/4" PEX x 3/4" PEX	Q4771307	1 3/16	1/8	15/16
		37	3	24
1 1/4" PEX x 1" PEX	Q4771310	1 7/16	1/8	1 3/16
		37	3	30
1 1/2" PEX x 3/4" PEX	Q4771507	1 11/16	1/8	15/16
		44	3	24
1 1/2" PEX x 1" PEX	Q4771510	1 11/16	1/8	1 3/16
		44	3	30
1 1/2" PEX x 1 1/4" PEX	Q4771513	1 11/16	1/8	1 7/16
		44	3	37
2" PEX x 1 1/2" PEX	Q4772015	2 3/16	1/4	1 11/16
		56	6	44
2 1/2" PEX x 1 1/4" PEX	Q4772513	2 13/16	1/4	1 7/16
		72	6	37
2 1/2" PEX x 1 1/2" PEX	Q4772515	2 13/16	1/4	1 11/16
		72	6	44
2 1/2" PEX x 2" PEX	Q4772520	2 13/16	1/4	2 3/16
		72	6	56
3" PEX x 2" PEX	Q4773020	3 3/8	1/4	2 3/16
		86	6	56
3" PEX x 2 1/2" PEX	Q4773025	3 3/8	1/4	2 13/16
		86	6	72

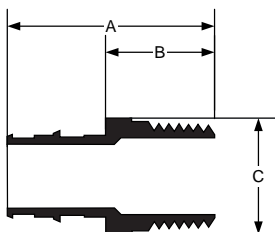

ProPEX brass male threaded adapters		A	B	C
Description	Part no.	in	in	in
		mm	mm	mm
3/8" PEX x 1/2" NPT	LF4523850	1 5/8	1	7/8
		41	25	22
1/2" PEX x 1/2" NPT	Q5525050	1 5/8	7/8	7/8
		41	23	22
	LF4525050	1 11/16	15/16	7/8
		42	24	22
1/2" PEX x 3/4" NPT	LF4525075	1 13/16	1 1/16	1 1/8
		45	27	29
3/4" PEX x 3/4" NPT	LF4527575	1 7/8	1	1 1/8
		48	25	29
	Q5527575	1 7/8	7/8	1 1/8
		47	23	29
3/4" PEX x 1" NPT	LF4527510	2 1/4	1 1/4	1 3/8
		56	32	35
	Q5527510	2	1 1/16	1 3/8
		51	27	35
1" PEX x 3/4" NPT	LF4521075	2 1/4	1 1/16	1 1/4
		57	27	32
	Q5521075	2 1/16	1 1/16	1 1/4
		53	27	32
1" PEX x 1" NPT	LF4521010	2 5/16	1 1/8	1 3/8
		59	29	35
	Q5521010	2 1/4	1 1/16	1 3/8
		57	27	35
1 1/4" PEX x 1 1/4" NPT	LF4521313	2 5/8	1 3/16	1 3/4
		66	30	44
	Q5521313	2 1/2	1 1/16	1 3/4
		64	27	44

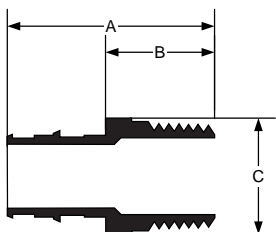

ProPEX brass male threaded adapters		A	B	C
Description	Part no.	in	in	in
		mm	mm	mm
1½" PEX x 1½" NPT	LF4521515	3 76	1¼ 32	2 51
	Q5521515	2 ¹⁵ / ₁₆ 74	1¼ 32	2 51
2" PEX x 2" NPT	LF4522020	3 ⁹ / ₁₆ 90	1¾ 35	2 ³ / ₈ 60
	Q5522020	3 ⁷ / ₁₆ 87	1 ⁵ / ₁₆ 33	2 ³ / ₈ 60
2½" PEX x 2½" NPT	LF4522525	4 ¹³ / ₁₆ 123	2 51	3¼ 83
	LF4523030	5½ 140	2½ 55	3¾ 95

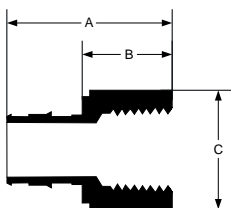

ProPEX brass female threaded adapters		A	B	C
Description	Part no.	in	in	in
		mm	mm	mm
1/2" PEX x 1/2" NPT	Q5575050	1 9/16	7/8	1
	LF4575050	40	22	25
1/2" PEX x 3/4" NPT	LF4575075	1 9/16	7/8	1
		40	22	25
1/2" PEX x 3/4" NPT	LF4575075	1 3/4	1 1/16	1 3/16
		44	26	30
3/4" PEX x 3/4" NPT	Q5577575	1 7/8	7/8	1 3/16
	LF4577575	47	23	30
3/4" PEX x 3/4" NPT	LF4577575	1 7/8	7/8	1 3/16
		47	23	30
3/4" PEX x 1" NPT	Q5577510	2 1/8	1 3/16	1 1/2
	LF4577510	54	32	38
3/4" PEX x 1" NPT	LF4577510	2 3/16	1 1/4	1 1/2
		56	32	38
1" PEX x 1" NPT	Q5571010	2 3/8	1 3/16	1 1/2
	LF4571010	60	30	38
1" PEX x 1" NPT	LF4571010	2 3/8	1 3/16	1 1/2
		60	30	38
1 1/4" PEX x 1 1/4" NPT	Q5571313	2 9/16	1 1/8	2
	LF4571313	65	28	51
1 1/4" PEX x 1 1/4" NPT	LF4571313	2 9/16	1 1/8	2
		65	28	51
1 1/2" PEX x 1 1/2" NPT	Q5571515	2 7/8	1 1/8	2 1/4
	LF4571515	73	29	57
1 1/2" PEX x 1 1/2" NPT	LF4571515	2 7/8	1 1/8	2 1/4
		73	29	57
2" PEX x 2" NPT	Q5572020	3 9/16	1 3/8	3
	LF4572020	90	35	76
2" PEX x 2" NPT	LF4572020	3 9/16	1 3/8	3
		90	35	76

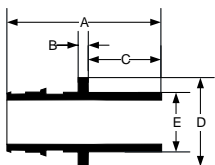

ProPEX brass fitting adapters		A	B	C	D	E
Description	Part no.	in	in	in	in	in
		mm	mm	mm	mm	mm
1/2" PEX x 1/2" Copper	LF4505050	1 3/8 35	1/8 3	9/16 14	3/4 19	5/8 16
	Q5505050	1 11/16 43	1/8 3	7/8 22	3/4 19	5/8 16
1/2" PEX x 3/4" Copper	LF4505075	1 5/8 42	1/8 3	13/16 21	15/16 23	7/8 22
	Q4506350	1 9/16 39	1/8 3	9/16 14	1 1/16 26	5/8 16
5/8" PEX x 3/4" Copper	Q4506375	1 13/16 46	1/8 3	13/16 21	15/16 24	7/8 22
	LF4507550	1 5/8 41	1/8 3	9/16 14	1 1/8 28	5/8 16
3/4" PEX x 1/2" Copper	Q5507550	1 15/16 50	1/8 3	7/8 22	1 1/8 28	5/8 16
	LF4507575	1 7/8 48	1/8 3	13/16 21	1 1/8 28	7/8 22
3/4" PEX x 3/4" Copper	Q5507575	2 1/16 53	1/8 3	1 25	1 1/8 28	7/8 22
	LF4507510	2 1/16 53	1/8 3	1 25	1 3/16 30	1 1/8 28
3/4" PEX x 1" Copper	Q5507510	2 1/16 53	1/8 3	1 25	1 1/8 29	1 1/8 28
	LF4501010	2 1/4 58	1/8 3	1 25	1 3/8 35	1 1/8 29
1" PEX x 1" Copper	Q5501010	2 5/16 59	1/8 3	1 25	1 3/8 35	1 1/8 29
	LF4501313	2 5/8 66	1/8 3	1 25	1 5/8 42	1 3/8 35
1 1/4" PEX x 1 1/4" Copper	Q5501313	2 11/16 69	1/8 3	1 1/8 29	1 3/4 44	1 3/8 35

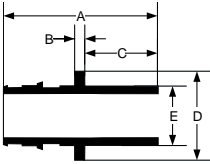

ProPEX brass fitting adapters		A	B	C	D	E
Description	Part no.	in	in	in	in	in
		mm	mm	mm	mm	mm
1½" PEX x 1½" Copper	LF4501515	3	⅛	1 ³ / ₁₆	1 ⁷ / ₈	1 ¹ / ₈
		76	3	29	48	41
	Q5501515	3 ³ / ₈	⅛	1 ⁹ / ₁₆	1 ⁷ / ₈	1 ¹ / ₈
		86	3	40	48	41
2" PEX x 2" Copper	LF4502020	3 ¹³ / ₁₆	¼	1 ⁷ / ₁₆	2 ⁵ / ₈	2 ¹ / ₈
		97	6	36	66	54
	Q5502020	4 ¹ / ₈	¼	1 ³ / ₄	2 ¹¹ / ₁₆	2 ¹ / ₈
		105	6	44	68	54

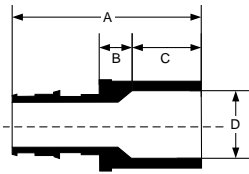

ProPEX brass sweat adapters		A	B	C	D
Description	Part no.	in	in	in	in
		mm	mm	mm	mm
3/8" PEX x 1/2" Copper	LF4513850	1 5/16	1/4	1/2	5/8
		34	6	13	16
1/2" PEX x 1/2" Copper	LF4515050	1 3/8	3/16	1/2	5/8
		35	5	13	16
	Q5515050	1 3/8	3/16	1/2	5/8
		35	5	13	16
1/2" PEX x 3/4" Copper	LF4515075	1 5/8	3/16	3/4	7/8
		41	5	19	22
3/4" PEX x 1/2" Copper	LF4517550	1 11/16	1/4	1/2	5/8
		42	6	13	16
	Q5517550	1 11/16	1/4	1/2	5/8
		42	6	13	16
3/4" PEX x 3/4" Copper	LF4517575	1 7/8	3/16	3/4	7/8
		47	5	19	22
	Q5517575	1 7/8	3/16	3/4	7/8
		47	5	19	22
3/4" PEX x 1" Copper	LF4517510	2 1/8	1/4	15/16	1 1/8
		53	6	23	29
	Q5517510	2 1/8	1/4	15/16	1 1/8
1" PEX x 1" Copper	LF4511010	2 1/4	3/16	15/16	1 1/8
		58	5	23	29
	Q5511010	2 1/4	3/16	15/16	1 1/8
		58	5	23	29
1 1/4" PEX x 1 1/4" Copper	LF4511313	2 5/8	3/16	1	1 3/8
		66	5	25	35
	Q5511313	2 5/8	3/16	1	1 3/8
		66	5	25	35

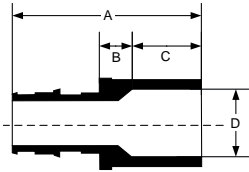

ProPEX brass sweat adapters		A	B	C	D
Description	Part no.	in	in	in	in
		mm	mm	mm	mm
1½" PEX x 1½" Copper	LF4511515	3 ³ / ₁₆	¼	1 ¹ / ₁₆	1 ⁵ / ₈
	Q5511515	78	6	28	41
2" PEX x 2" Copper	LF4512020	3 ³ / ₄	¼	1 ⁵ / ₁₆	2 ¹ / ₈
	Q5512020	95	6	34	54
2½" PEX x 2½" Copper	LF4512525	4 ⁹ / ₁₆	5 ¹ / ₁₆	1 ⁷ / ₁₆	2 ⁵ / ₈
		116	8	37	67
3" PEX x 3" Copper	LF4513030	5 ⁵ / ₁₆	5 ¹ / ₁₆	1 ¹¹ / ₁₆	3 ¹ / ₈
		135	8	42	80

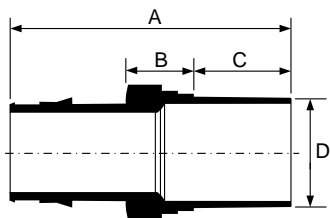

ProPEX LF brass copper press fitting adapters		A	B	C	D
Description	Part no.	in	in	in	in
		mm	mm	mm	mm
1/2" PEX x 1/2" copper	LFP4505050	2	9/16	3/4	5/8
		51	14	19	16
3/4" PEX x 3/4" copper	LFP4507575	2 3/8	5/8	7/8	7/8
		61	15	22	22
1" PEX x 1" copper	LFP4501010	2 7/8	1 1/16	1	1 1/8
		73	17	25	29
1 1/4" PEX x 1 1/4" copper	LFP4501313	3 5/16	3/4	1 1/16	1 3/8
		84	19	27	35
1 1/2" PEX x 1 1/2" copper	LFP4501515	3 3/8	3/4	1 7/16	1 5/8
		99	19	36	41
2" PEX x 2" copper	LFP4502020	4 5/8	1 5/16	1 9/16	2 1/8
		118	24	40	54
2 1/2" PEX x 2 1/2" copper	LFP4502525	5 7/8	1 3/8	1 5/8	2 5/8
		149	36	41	67
3" PEX x 3" copper	LFP4503030	6 11/16	1 1/2	1 13/16	3 1/8
		169	38	46	79

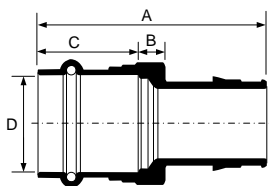

1/2" to 2" sizes

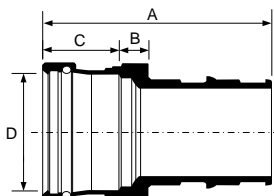

2 1/2" to 3" sizes

ProPEX LF brass copper press adapters		A	B	C	D
Description	Part no.	in	in	in	in
		mm	mm	mm	mm
1/2" PEX x 1/2" copper	LFP4515050	2 1/16	7/16	7/8	5/8
		53	11	22	16
3/4" PEX x 3/4" copper	LFP4517575	2 3/8	9/16	7/8	7/8
		61	14	22	22
1" PEX x 1" copper	LFP4511010	2 11/16	5/16	1 3/16	1 1/8
		68	8	30	29
1 1/4" PEX x 1 1/4" copper	LFP4511313	3 1/8	9/16	1	1 3/8
		77	14	25	35
1 1/2" PEX x 1 1/2" copper	LFP4511515	3 5/8	9/16	1 5/16	1 5/8
		91	14	34	42
2" PEX x 2" copper	LFP4512020	4 5/8	1/2	2	2 1/8
		118	12	51	54
2 1/2" PEX x 2 1/2" copper	LFP4512525	5 1/4	1 1/16	1 3/4	2 5/8
		133	17	44	67
3" PEX x 3" copper	LFP4513030	6 1/8	1 5/16	1 15/16	3 1/8
		156	24	49	80

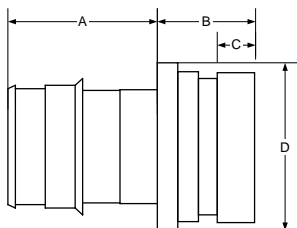

ProPEX LF brass groove fitting adapters		A	B	C	D
Description	Part no.	in	in	in	in
		mm	mm	mm	mm
2" PEX x 2" CTS Groove	LFV2962020	2 ¹ / ₈	1 ¹ / ₂	5 ⁵ / ₈	2 ¹¹ / ₁₆
		54	38	15	68
2" PEX x 2 ¹ / ₂ " CTS Groove	LFV2962025	2 ¹ / ₈	1 ¹ / ₂	5 ⁵ / ₈	2 ¹¹ / ₁₆
		54	38	15	68
2 ¹ / ₂ " PEX x 2 ¹ / ₂ " CTS Groove	LFV2962525	2 ¹³ / ₁₆	1 ¹ / ₂	5 ⁵ / ₈	3 ³ / ₈
		72	38	15	86
3" PEX x 3" CTS Groove	LFV2963030	3 ³ / ₈	1 ¹ / ₂	5 ⁵ / ₈	3 ¹³ / ₁₆
		86	38	15	96
2" PEX x 2" IPS Groove	LFV2972020	2 ¹ / ₈	1 ¹ / ₂	5 ⁵ / ₈	2 ¹¹ / ₁₆
		54	38	15	68
2" PEX x 2 ¹ / ₂ " IPS Groove	LFV2972025	2 ¹ / ₈	1 ¹ / ₂	5 ⁵ / ₈	2 ⁷ / ₈
		54	38	15	73
2 ¹ / ₂ " PEX x 2" IPS Groove	LFV2972520	2 ¹³ / ₁₆	1 ¹ / ₂	5 ⁵ / ₈	3 ³ / ₈
		72	38	15	86
2 ¹ / ₂ " PEX x 2 ¹ / ₂ " IPS Groove	LFV2972525	2 ¹³ / ₁₆	1 ¹ / ₂	5 ⁵ / ₈	3 ³ / ₈
		72	38	15	86

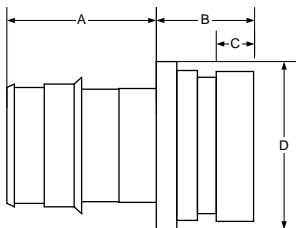

ProPEX LF brass groove fitting adapters		A	B	C	D
Description	Part no.	in	in	in	in
		mm	mm	mm	mm
2½" PEX x 3" IPS Groove	LFV2972530	2 ¹³ / ₁₆	1½	5/8	3½
		72	38	15	89
3" PEX x 2½" IPS Groove	LFV2973025	3 ³ / ₈	1½	5/8	3 ¹³ / ₁₆
		86	38	15	96
3" PEX x 3" IPS Groove	LFV2973030	3 ³ / ₈	1½	5/8	3 ¹³ / ₁₆
		86	38	15	96

ProPEX LF brass flange adapter		A	B	C	D
Description	Part no.	in	in	in	in
		mm	mm	mm	mm
2½" PEX x Flange	LF2982525	3¾	5/8	2 ¹³ / ₁₆	7
		96	16	72	178
3" PEX x Flange	LF2983030	4 ⁵ / ₁₆	5/8	4 ¹ / ₁₆	7½
		110	16	104	191

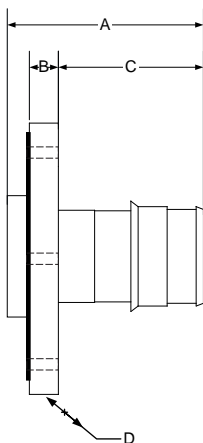

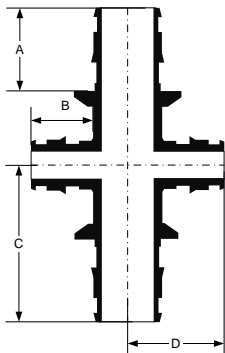

ProPEX EP opposing-port tees		A	B	C	D
Description	Part no.	in	in	in	in
		mm	mm	mm	mm
1" PEX x 1" PEX x ¾" PEX x ¾" PEX	Q4801075	1 ³ / ₁₆	1 ⁵ / ₁₆	2 ¹ / ₁₆	1 ⁵ / ₈
		30	24	53	41
1¼" PEX x 1¼" PEX x ¾" PEX x ¾" PEX	Q4801375	1 ⁷ / ₁₆	1 ⁵ / ₁₆	2 ³ / ₈	1 ³ / ₄
		37	24	60	44
1½" PEX x 1½" PEX x ¾" PEX x ¾" PEX	Q4801575	1 ¹¹ / ₁₆	1 ⁵ / ₁₆	2 ¹¹ / ₁₆	1 ¹⁵ / ₁₆
		43	24	69	49
2" PEX x 2" PEX x ¾" PEX x ¾" PEX	Q4802075	2 ³ / ₁₆	1 ⁵ / ₁₆	3 ³ / ₁₆	2
		56	24	81	51

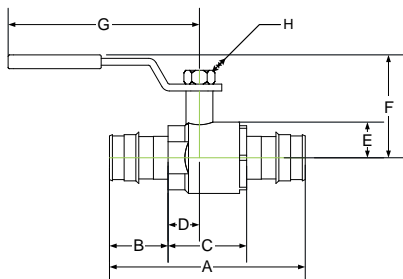

ProPEX brass ball valves		A	B	C	D	E	F	G	H
Description	Part no.	in	in	in	in	in	in	in	in
		mm	mm	mm	mm	mm	mm	mm	mm
1/2" PEX x 1/2" PEX	A3205050	2 1/2	1 1/8	1 1/8	3/8	1/2	1 11/16	3 3/8	3/8
	LFC4825050	64	18	27	10	12	43	86	10
3/4" PEX x 3/4" PEX	A3207575	3 3/8	1 5/8	1 1/2	1/2	1/2	1 7/8	3 3/8	3/8
	LFC4827575	86	24	38	12	12	47	86	10
1" PEX x 1" PEX	A3201010	4 3/8	1 3/8	1 13/16	3/4	13/16	1 7/8	4 7/16	1/2
	LFC4821010	106	30	46	19	20	48	114	12
1 1/4" PEX x 1 1/4" PEX	A3201313	4 13/16	1 7/8	1 15/16	5/8	15/16	2 1/4	4 7/16	1/2
	LFC4821313	122	37	49	17	24	58	114	12
1 1/2" PEX x 1 1/2" PEX	A3201515	5 11/16	1 11/16	2 1/8	15/16	1 1/8	2 11/16	5 9/16	9/16
	LFC4821515	145	43	58	23	28	69	142	14
2" PEX x 2" PEX	A3202020	7 1/8	2 1/8	2 13/16	1 1/8	1 7/8	3 3/8	5 9/16	9/16
	LFC4822020	181	55	72	28	37	86	142	14

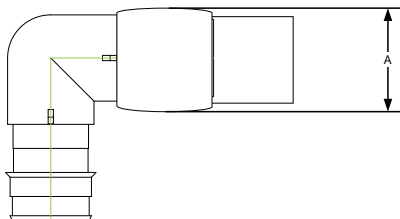

ProPEX ring installed diameter		A
Description	Part no.	in
		mm
1/2" ProPEX ring with stop	Q4690512	15/16
		24
3/4" ProPEX ring with stop	Q4690756	1 1/4
		32
1" ProPEX ring with stop	Q4691000	1 9/16
		40
1 1/4" ProPEX ring with stop	Q4691250	1 13/16
		47
1 1/2" ProPEX ring with stop	Q4691500	2 1/16
		53
2" ProPEX ring with stop	Q4692000	2 15/16
		74
2 1/2" ProPEX ring with stop	Q4692500	3 9/16
		91
3" ProPEX ring with stop	Q4693000	4 1/4
		108

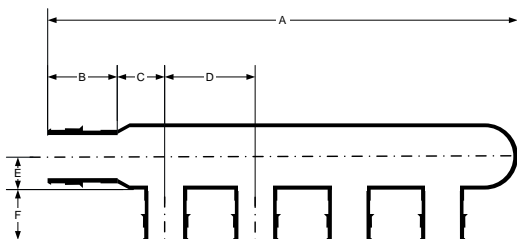

EP branch multiport tees		A	B	C	D	E	F
Description	Part no.	in	in	in	in	in	in
		mm	mm	mm	mm	mm	mm
3/4" EP Branch Multiport Tee, 3 outlets	Q2237550	5/8	15/16	5/8	1 1/4	7/16	3/4
		131	24	16	32	12	19
1 1/4" EP Branch Multiport Tee, 3 outlets	Q2231375	6 7/8	1 7/16	7/8	1 3/4	1 1/16	1 5/16
		174	37	23	44	18	24
3/4" EP Branch Multiport Tee, 4 outlets	Q2247550	6 3/8	1 5/16	5/8	1 1/4	7/16	3/4
		163	24	16	32	12	19
1" EP Branch Multiport Tee, 4 outlets	Q2241050	6 11/16	1 3/16	1 3/16	1 1/4	5/8	3/4
		170	30	21	32	15	19
3/4" EP Branch Multiport Tee, 6 outlets	Q2267550	8 7/8	1 5/16	5/8	1 1/4	7/16	3/4
		226	24	16	32	12	19
1" EP Branch Multiport Tee, 6 outlets	Q2261050	9 1/4	1 3/16	5/8	1 1/4	9/16	3/4
		235	30	16	32	14	19

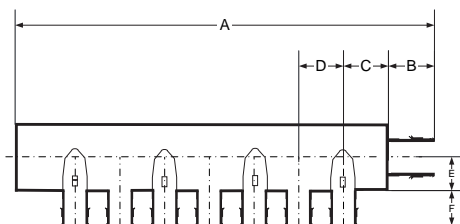

Commercial EP branch multiport tees		A	B	C	D	E	F
Description	Part no.	in	in	in	in	in	in
		mm	mm	mm	mm	mm	mm
3/4" EP Branch Multiport Tee, 7 outlets	Q2277550	8 ¹¹ / ₁₆	1 ⁵ / ₁₆	1 ¹ / ₈	7/8	1 ¹ / ₁₆	3/4
3/4" EP Branch Multiport Tee, 8 outlets	Q2287550	9 ⁹ / ₁₆	1 ⁵ / ₁₆	1 ¹ / ₈	7/8	1 ¹ / ₁₆	3/4
1" EP Branch Multiport Tee, 7 outlets	Q2271051	8 ⁷ / ₈	1 ³ / ₁₆	1 ¹ / ₈	7/8	1 ¹ / ₁₆	3/4
1" EP Branch Multiport Tee, 8 outlets	Q2281051	9 ¹³ / ₁₆	1 ³ / ₁₆	1 ¹ / ₈	7/8	1 ¹ / ₁₆	3/4
1" EP Branch Multiport Tee, 10 outlets	Q2101051	11 ⁹ / ₁₆	1 ³ / ₁₆	1 ¹ / ₈	7/8	1 ¹ / ₁₆	3/4
1" EP Branch Multiport Tee, 12 outlets	Q2121051	13 ³ / ₈	1 ³ / ₁₆	1 ¹ / ₈	7/8	1 ¹ / ₁₆	3/4

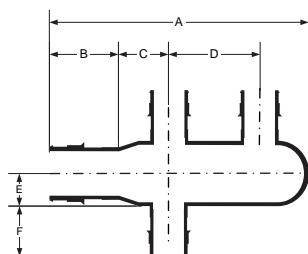

EP branch opposing-port multiport tees		A	B	C	D	E	F
Description	Part no.	in	in	in	in	in	in
		mm	mm	mm	mm	mm	mm
3/4" EP Branch Opposing-port Multiport Tee, 3 outlets	Q2337550	3 ⁹ / ₁₆	1 ⁵ / ₁₆	5/8	1 ¹ / ₄	7/16	3/4
3/4" EP Branch Opposing-port Multiport Tee, 4 outlets	Q2347550	3 ⁹ / ₁₆	1 ⁵ / ₁₆	5/8	1 ¹ / ₄	7/16	3/4
3/4" EP Branch Opposing-port Multiport Tee, 8 outlets	Q2387550	6 ¹ / ₁₆	1 ⁵ / ₁₆	5/8	1 ¹ / ₄	7/16	3/4

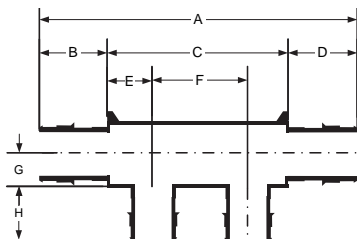

EP flow-through multiport tees		A	B	C	D	E	F	G	H
Description	Part no.	in	in	in	in	in	in	in	in
		mm	mm	mm	mm	mm	mm	mm	mm
2 outlets, 3/4" x 3/4"	Q2227557	4 3/8	1 5/16	2 1/2	1 5/16	5/8	1 1/4	7/16	3/4
		112	24	64	24	16	32	11	19
3 outlets, 3/4" x 3/4"	Q2237557	5 11/16	1 5/16	3 3/4	1 5/16	5/8	1 1/4	7/16	3/4
		143	24	95	24	16	32	11	19
3 outlets, 1" x 3/4"	Q2231057	6 3/16	1 3/16	4 1/16	1 5/16	3/4	1 1/4	9/16	3/4
		157	30	103	24	19	32	14	19
3 outlets, 1 3/4" x 1 1/4"	Q2231373	8 3/16	1 7/16	5 5/16	1 7/16	7/8	1 3/4	5/8	1
		208	37	135	37	23	44	17	25
3 outlets, 2" x 2"	Q2232102	10 5/8	2 3/16	6 1/4	2 3/16	1 1/8	2	1 5/16	1 5/16
		269	56	158	56	28	51	24	33
4 outlets, 3/4" x 3/4"	Q2247557	7 13/16	1 5/16	5 7/8	1 5/16	1 1/16	1 1/2	7/16	3/4
		198	24	150	24	18	38	11	19
4 outlets, 1" x 3/4"	Q2241057	7 1/8	1 3/16	5	1 5/16	5/8	1 1/4	9/16	3/4
		180	30	127	24	16	32	14	19
4 outlets, 1" x 1"	Q2241051	7 11/16	1 3/16	5 5/16	1 3/16	3/4	1 1/4	9/16	3/4
		195	30	135	30	19	32	14	19
6 outlets, 3/4" x 3/4"	Q2267557	9 3/8	1 5/16	7 1/2	1 5/16	5/8	1 1/4	7/16	3/4
		239	24	191	24	16	32	11	19
6 outlets, 1" x 3/4"	Q2261057	9 5/8	1 3/16	7 1/2	1 5/16	5/8	1 1/4	9/16	3/4
		244	30	191	24	16	32	14	19
6 outlets, 1" x 1"	Q2261051	9 7/8	1 3/16	7 1/2	1 3/16	5/8	1 1/4	9/16	3/4
		251	30	191	30	16	32	14	19

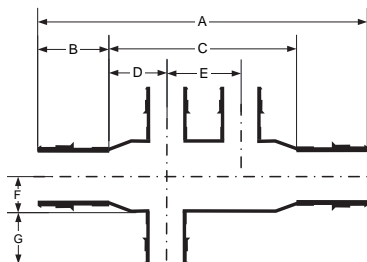

EP flow-through opposing-port multipoint tees		A	B	C	D	E	F	G
Description	Part no.	in	in	in	in	in	in	in
		mm	mm	mm	mm	mm	mm	mm
3 outlets, 3/4" x 3/4"	Q2337557	4 ⁷ / ₁₆	1 ⁵ / ₁₆	2 1/2	5/8	1 1/4	1/2	3/4
		112	24	63	16	32	12	19
4 outlets, 3/4" x 3/4"	Q2347557	4 ⁷ / ₁₆	1 ⁵ / ₁₆	2 1/2	5/8	1 1/4	1/2	3/4
		112	24	63	16	32	12	19
6 outlets, 3/4" x 3/4"	Q2367557	5 ¹¹ / ₁₆	1 ⁵ / ₁₆	3 3/4	5/8	1 1/4	1/2	3/4
		144	24	95	16	32	12	19

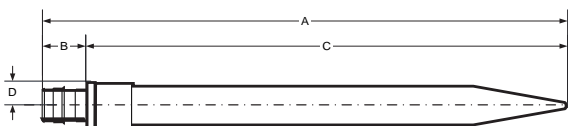

ProPEX LF copper straight stubs		A	B	C	D
Description	Part no.	in	in	in	in
		mm	mm	mm	mm
1/2" PEX LF Brass x 1/2" Copper, 8"	LF2935050	8 ⁵ / ₁₆	1 ¹ / ₁₆	7 ⁹ / ₁₆	3/8
		211	18	193	10
1/2" PEX LF Brass x 1/2" Copper, 15"	LF2945050	14 ¹ / ₂	1 ¹ / ₁₆	13 ¹⁹ / ₁₆	3/8
		368	18	350	10
2 1/2" PEX LF Brass x 2 1/2" Copper	LF2962525	12 ¹ / ₈	2 ¹⁹ / ₁₆	9 1/4	1 ¹³ / ₁₆
		308	72	236	46
3" PEX LF Brass x 3" Copper	LF2963030	13 ¹¹ / ₁₆	3 ³ / ₈	10 ⁵ / ₁₆	2 ¹ / ₈
		347	86	261	53

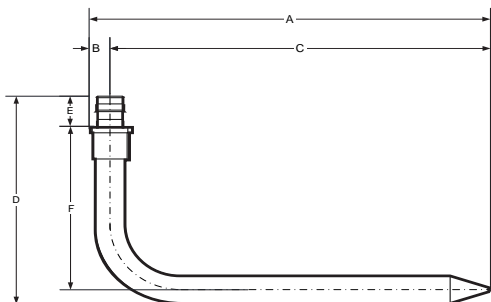

ProPEX LF copper stub ells		A	B	C	D	E	F
Description	Part no.	in	in	in	in	in	in
		mm	mm	mm	mm	mm	mm
1/2" PEX LF Brass x 1/2" Copper, 3 1/2" x 8"	LF2865050	8 3/8	3/8	8	4 3/4	1 1/16	3 3/4
		213	10	203	121	18	95
1/2" PEX LF Brass x 1/2" Copper, 13" x 8"	LF2855050	8 3/8	3/8	8	13 5/16	1 1/16	12 5/16
		213	10	203	338	18	312
1/2" PEX LF Brass x 1/2" Copper, 8" x 13"	LF2895050	13 3/8	3/8	13	13 5/16	1 1/16	7 5/16
		340	10	330	338	18	185
3/4" PEX LF Brass x 3/4" Copper, 4" x 8"	LF2897575	8 9/16	9/16	8	5 7/16	1 5/16	4 1/16
		217	14	203	138	24	103
1" PEX LF Brass x 1" Copper, 12" x 12"	LF2891010	13 11/16	1 1/16	13	16	1 3/16	14 1/4
		347	17	330	406	30	362

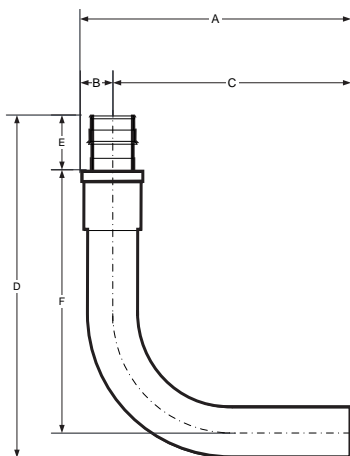

ProPEX LF copper tub ells		A	B	C	D	E	F
Description	Part no.	in	in	in	in	in	in
		mm	mm	mm	mm	mm	mm
1/2" PEX LF Brass x 1/2" Copper, 3" x 6"	LF2875050	3 3/8	3/8	3	6 5/16	1 1/16	5 1/4
		86	10	76	160	18	134
1/2" PEX LF Brass x 1/2" Copper, 3" x 4"	LF2885050	3 3/8	3/8	3	4 5/16	1 1/16	3 1/4
		86	10	76	109	18	83

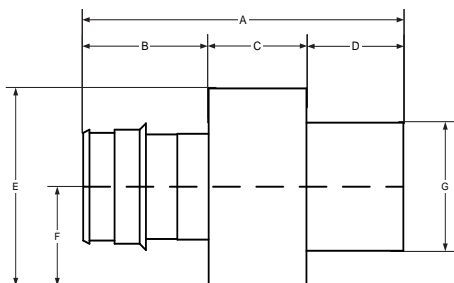

ProPEX LF brass CPVC spigot adapters		A	B	C	D	E	F	G
Description	Part no.	in	in	in	in	in	in	in
		mm	mm	mm	mm	mm	mm	mm
1¼" PEX x 1¼" CPVC (CTS)	CP4501313	3 ¹¹ / ₁₆	1 ⁷ / ₁₆	1 ¹ / ₈	1 ¹ / ₈	2 ¹ / ₈	1 ¹ / ₁₆	*
		94	37	29	29	54	27	35
1½" PEX x 1½" CPVC (CTS)	CP4501515	4 ³ / ₁₆	1 ¹¹ / ₁₆	1 ³ / ₁₆	1 ⁵ / ₁₆	2 ³ / ₈	1 ³ / ₁₆	1 ⁵ / ₈
		107	43	30	34	61	30	41
2" PEX x 2" CPVC (CTS)	CP4502020	5 ³ / ₁₆	2 ³ / ₁₆	1 ⁷ / ₁₆	1¾	3	1½	2 ¹ / ₈
		134	56	36	44	76	38	54

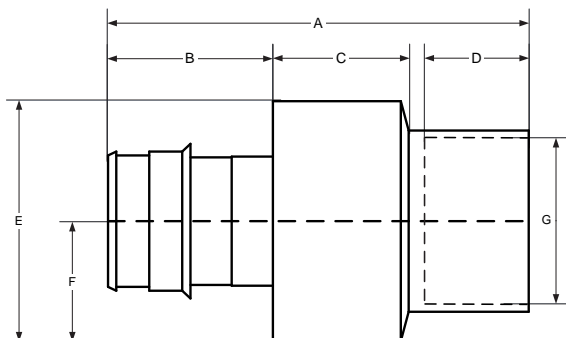

ProPEX LF brass CPVC socket adapters		A	B	C	D	E	F	G
Description	Part no.	in	in	in	in	in	in	in
		mm	mm	mm	mm	mm	mm	mm
1¼" PEX x 1¼" CPVC (CTS)	CP4511313	3 ¹¹ / ₁₆	1 ⁷ / ₁₆	1¼	1	2 ⁵ / ₈	1 ¹ / ₁₆	1 ³ / ₈
		94	37	32	26	54	27	35
1½" PEX x 1½" CPVC (CTS)	CP4511515	4 ³ / ₁₆	1 ¹¹ / ₁₆	1¼	1 ⁵ / ₁₆	2 ³ / ₈	1 ³ / ₁₆	1 ⁵ / ₈
		106	43	32	33	61	30	42
2" PEX x 2" CPVC (CTS)	CP4512020	5 ³ / ₁₆	2 ³ / ₁₆	1 ³ / ₈	2	3	1½	2 ¹ / ₈
		133	56	35	43	76	38	54

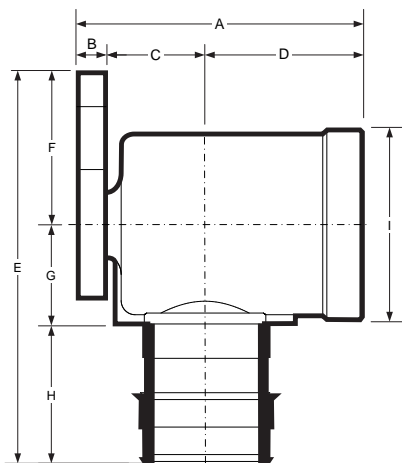

ProPEX LF brass drop ear elbow		A	B	C	D	E	F	G	H	I
Description	Part no.	in	in	in	in	in	in	in	in	in
		mm	mm	mm	mm	mm	mm	mm	mm	mm
1/2" PEX x 1/2" FIP	LF4235050	1 11/16	1/4	7/16	1	2 3/16	1	9/16	1 1/16	1 1/16
		43	6	11	26	56	26	14	18	26
3/4" PEX x 3/4" FIP	LF4237575	1 15/16	1/4	3/4	1	2 3/16	1 3/16	1 1/16	1 5/16	1 3/8
		49	6	19	26	56	29	17	24	35
1" PEX x 3/4" FIP	LF4231010	2 7/16	1/4	7/8	1 1/4	3 5/16	1 5/16	7/8	1 3/16	1 5/8
		62	6	22	32	84	33	22	30	42

Appendix D:

Uponor piping systems installation test questions

Please circle the correct answer below.

Section 1 – General installations

1. When making a ProPEX connection...

- a. Place the ProPEX ring on the pipe to the stop edge
- b. Make sure the head is installed and rotating properly
- c. Do not force the pipe onto the head when expanding
- d. Completely insert the fitting so the pipe/ring reach the fitting shoulder
- e. All of the above

2. Maintain a minimum distance between ProPEX fittings...

- a. To prevent damage to fittings
- b. To prevent damage to expander heads
- c. All of the above

3. When storing Uponor PEX piping...

- a. Keep in its original packaging
- b. Keep out of direct UV light
- c. All of the above

4. When making ProPEX-to-copper transitions...

- a. Maintain a minimum of 18" between solder/sweat and ProPEX connections
- b. Make solder/sweat connections prior to making ProPEX connections
- c. Use ProPEX copper press adapters for a flameless transition
- d. All of the above

5. Uponor's full 25-year warranty requires using Uponor PEX pipe with Uponor ProPEX rings and fittings.

- a. True
- b. False

Section 2 – Residential and in-suite installations

6. Per the IPC and UPC, support bare Uponor PEX piping...

- a. Every 32" (0.8m) horizontally for 1" and smaller pipe
- b. Every 48" (1.2m) for 1¼" and larger pipe
- c. Every 5 ft. (1.5m) vertically for all pipe sizes
- d. All of the above

7. When installing Uponor PEX systems, be sure to...

- a. Maintain a minimum distance of 12" (0.3m) from recessed light fixtures (unless insulated with suitable insulation)
- b. Maintain a minimum distance of 5 ft. (1.5m) from fluorescent lights (unless insulated with suitable insulation)
- c. Not use PEX between the tub/shower valve and tub spout
- d. All of the above

8. When installing Uponor PEX piping systems below grade...

- a. Use engineered polymer (EP) fittings approved for direct burial
- b. Cover brass fittings with a minimum 6-mil poly wrap
- c. Sleeve through concrete/masonry penetrations
- d. All of the above

9. When pressure testing Uponor PEX piping systems...

- a. Pressurize to 25 psi above working pressure or 100 psi
- b. Use a mixture of water and air
- c. Use air when allowed by local code
- d. All of the above

Section 3 – Commercial installations

10. PEX pipe must be protected when passing through steel framing.

- a. True
- b. False

11. What are the horizontal support requirements when using PEX-a Pipe Support?

- a. Maximum support distance is 8 ft. (2.4m) for all pipe sizes
- b. Support fittings 1½" and smaller within 12" (0.3m)
- c. Clamp the pipe at a maximum of 32 ft. (9.7m)
- d. All of the above

12. When installing PEX-a Pipe Support...

- a. Minimize cutting by using full lengths when possible
- b. Deburr sharp edges if cutting is required
- c. Strap according to **Figures 35-38** in this guide
- d. All of the above

13. To minimize expansion and contraction in systems with ΔT s greater than 40°F (22.2°C)...

- a. Support PEX with PEX-a Pipe Support and included straps
- b. Clamp the pipe at a maximum 32 ft. (9.7m) on center
- c. Use fixed points according to length of run and pipe size
- d. All of the above

14. When installing Uponor PEX piping for vertical riser applications...

- a. Support at the base of each floor with a CTS riser clamp
- b. Support every 5 ft. (1.5m)
- c. Clamp at the top of the floors according to system type (e.g., domestic hot water, heating hot water, etc.)
- d. All of the above

15. When pressure testing large-volume commercial PEX systems...

- a. Fill system with potable water, air or a combination of both
- b. Condition the pipe to 1.5 times the test pressure or 120 psi (8.2 bar) for 30 minutes
- c. After 30 minutes, release excess pressure until you reach desired test pressure [80 psi (5.5 bar) recommended]
- d. Monitor system for leaks over the required time period
- e. All of the above

Uponor, Inc.

5925 148th Street West
Apple Valley, MN 55124
USA

T 800.321.4739

F 952.891.2008

Uponor, Ltd.

6510 Kennedy Road
Mississauga, ON L5T 2X4
CANADA

T 888.994.7726

F 800.638.9517

uponor

uponorpro.com

uponor

Plumbing Design Assistance Manual (PDAM)



Plumbing Design Assistance Manual

is published by

Uponor Inc.

5925 148th Street West
Apple Valley, MN 55124 USA
T 800.321.4739
F 952.891.2008

Uponor Ltd.

6510 Kennedy Road
Mississauga, ON L5T 2X4 CANADA
T 888.994.7726
F 800.638.9517

uponorpro.com

uponorengineering.com

© 2019 Uponor
All rights reserved.

Fifth Edition
First printing March 2008
Printed in the United States of America

Uponor has used reasonable efforts in collecting, preparing and providing quality information and material in this manual. However, system enhancements may result in modification of features or specifications without notice.

Uponor is not liable for installation practices that deviate from this manual or are not acceptable practices within the mechanical trades.

Table of Contents

Plumbing Design Assistance Manual

Foreword	iv
Chapter 1: Uponor PEX properties	1
Uponor PEX properties	1
PEX-a distinctions	1
Stress resistance	1
Cleanliness of Uponor PEX.	1
Ultraviolet (UV) resistance	2
Chemical resistance	2
Oxidative resistance	2
Hydrostatic temperature and pressure ratings	3
Interpolation method	3
Excessive temperature and pressure capability	3
Standards, codes and listings	4
ProPEX® fittings.	5
Uponor ProPEX engineered polymer (EP) fittings	5
The strength of Uponor EP	6
Uponor ProPEX lead-free (LF) brass fittings	6
Fittings by others	6
Chapter 2: Making ProPEX connections	7
Distance between fittings	7
General ProPEX connection tips	7
Making ProPEX connections with Milwaukee® M12™ or M18™ ProPEX expansion tools	8
With auto rotation (standard Milwaukee heads)	8
Without auto rotation (standard Uponor heads)	8
Making ProPEX connections with Milwaukee M18 FORCELOGIC™ ProPEX expansion tools.	10
FORCELOGIC expansion head installation	10
Making a ProPEX connection	11
Making ProPEX connections with ProPEX 201 corded expander tools	12
Making 3/8" ProPEX connections	14
Proper expander tool and head maintenance	14
Disconnecting a ProPEX brass fitting	15
Troubleshooting ProPEX connections	16
Chapter 3: Fire-resistant construction	17
Wood-frame assemblies	17
Wood-frame floor/ceiling assemblies	17
Steel/concrete wall assemblies.	18
Steel/concrete floor/ceiling assemblies.	18
Wood-frame assemblies (U.S.).	19
Wood-frame assemblies (Canada)	21
Concrete assemblies (U.S.)	23
Concrete assemblies (Canada).	24
ASTM E814 or CAN/ULC-S115	25
Fire stopping solutions	25

ASTM E814 and CAN/ULC-S115 listings	27
Cast-in-place sleeves	28
ASTM E84 — surface burning characteristics	29
CAN/ULC-S102.2 — surface burning characteristics	31
Underwriters Laboratories (UL) 2846.	34
Chapter 4: Pipe sizing	35
Standard dimension ratio	35
Temperature and pressure ratings	35
Pipe sizing an Uponor AquaPEX® plumbing system	35
Uniform friction loss method	37
Uponor AquaPEX design parameters	39
Friction loss with Uponor PEX piping.	40
Darcy-Weisbach method	40
Hazen-Williams method.	41
Comparing Darcy-Weisbach and Hazen-Williams	42
Friction loss of fittings.	42
The C_v method for calculating friction loss	43
UPC table 610.4	44
IPC table E201.1	45
NPCC table A-2.6.3.1(2)A	47
NPCC table 2.6.3.2	48
Chapter 5: System design and layout	51
The Uponor advantage	51
Unit/in-suite piping	51
Uponor Logic plumbing	52
Efficiencies of Uponor Logic	53
Hot-water performance	53
Reverse osmosis and de-ionized water systems.	54
Surge pressure and sound intensity	54
Water hammer	54
Water hammer arrestors	54
Hot-water system design	55
Recirculated hot-water systems	55
Balancing of recirculated hot-water systems	55
Heat trace	56
Thermal conductivity	56
Insulation	56
Pre-insulated Uponor AquaPEX piping.	56
Uponor PEX vs. copper heat loss comparison — Btu/(hr•ft).	57
Uponor Ecoflex® products	58
Thermal expansion and contraction	59
Chapter 6: Installation methods.	63
Local code approvals	63
Storing and handling PEX	63
Uncoiling PEX	64
Bending PEX	64

Reforming kinked piping	64
Thawing frozen piping	64
Supporting Uponor PEX pipe	65
Supporting fittings and valves	66
Uponor PEX-a Pipe Support	68
General requirements for PEX-a Pipe Support.	69
Strapping requirements for PEX-a Pipe Support.	71
ASTM E84 requirements for PEX-a Pipe Support	72
Expansion and contraction control with PEX-a Pipe Support	72
Supporting Uponor multiport tees	73
Vertical support requirements	75
Support methods	76
Expansion-compensating devices	79
Expansion and contraction: cold-water risers	80
Expansion and contraction: hot-water risers	80
Public-use fixtures	81
Pipe labels	81
Commercial flush bank detail.	81
Below-grade and in-slab installation	82
Pre-insulated Uponor AquaPEX piping.	82
Pre-sleeved Uponor AquaPEX piping	82
Water service requirements	82
Trace wire	82
Trench bottom preparation	84
Piping embedment	84
H-20 loads	85
Horizontal directional drilling (HDD)	85
Water system disinfection	86
Pressure-testing procedures	86
Insulation	87
Icynene® spray foam insulation.	87
Closed-cell spray foams	87
Recessed light fixtures	87
Painting Uponor AquaPEX	88
Termiticides/pesticides	88
Appendix A: Fluid properties	89
Appendix B: Uponor PEX friction loss tables	91
Appendix C: Fitting equivalent length	101
Appendix D: ProPEX fitting dimensions	111
Appendix E: Expansion arm and loop calculations	131
Appendix F: Pipe heat loss and surface temperature	161

Foreword

This design assistance manual is published for architects, building officials, engineers and mechanical contractors interested in Uponor professional plumbing systems. It describes general installation recommendations that use Uponor AquaPEX® piping products. Refer to local codes for additional requirements.

Uponor made reasonable efforts to collect, prepare and provide quality information and material in this manual. However, system enhancements may result in modification of features or specifications without notice.

Uponor is not liable for installation practices that deviate from this manual or are not acceptable practices within the mechanical trades, codes or standards of practice.

Refer to the Uponor AquaSAFE™ Installation Guide to install a combination plumbing and fire safety system using Uponor products.

Direct any questions regarding the suitability of an application or a specific design to a local Uponor representative by calling toll free 888.594.7726 (United States) or 888.994.7726 (Canada).

Note that this manual is available in English, Spanish and French at no charge. To order additional copies, go to uponorpro.com/pdam.



Chapter 1:

Uponor PEX properties

Uponor PEX properties

PEX is an acronym for crosslinked polyethylene. The “PE” refers to the raw material used to make polyethylene; the “X” refers to the crosslinking of the polyethylene across its molecular chains.

The molecular chains are linked into a three-dimensional network that makes PEX remarkably durable within a wide range of temperatures and pressures.

Currently, three methods exist for producing PEX.

- Engel or peroxide method (PEX-a)
- Silane method (PEX-b)
- Electron beam (e-beam) or radiation method (PEX-c)

All three processes generate pipe that is crosslinked to various degrees according to ASTM F876 and F877 standards.

Uponor manufactures Engel-method PEX-a pipe. The PEX industry considers this pipe superior because the crosslinking is done during the manufacturing process when the polyethylene is in its amorphous state (above the crystalline melting point). Accordingly, the degree of crosslinking reaches more than 80%, resulting in a more uniform product with no weak links in the molecular chain.

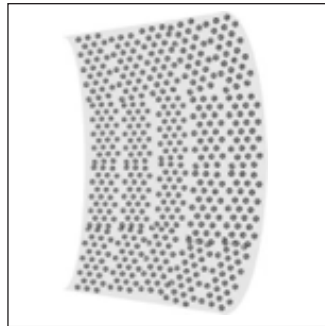

Figure 1-1: PEX-a (Engel) 80%+ crosslinked

PEX-a distinctions

The properties of PEX-a pipe make it the most flexible PEX on the market. This flexibility allows the tightest bend radius available — six times the outside diameter of the pipe. Its flexibility also greatly reduces instances of kinked pipe. And in the rare instance of a kink, the thermal memory of PEX-a allows kink repair with a simple shot of heat from a heat gun.

The pipe’s shape memory also offers the unique opportunity for ProPEX® fitting connections. Shape memory allows PEX-a to expand and then shrink back to normal size — creating strong, durable and reliable fitting connections.

Finally, PEX-a pipe offers more resistance to crack propagation (how a crack grows) than PEX-b or PEX-c pipe. A crack that occurs in PEX-a pipe is the least likely to grow over time and cause leaks or damage.

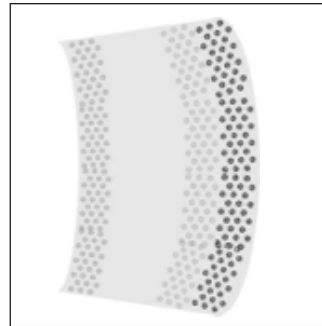

Figure 1-2: PEX-b (Silane) 65-70% crosslinked

Stress resistance

Pipe installed in commercial applications must be capable of withstanding the stresses that result from installation within commercial buildings.

Typical stresses include:

- Expansion and contraction that result from repeated heating and subsequent cooling of the heat-transfer fluid
- Mechanical abrasion, shearing and stretching that occurs as a result of installation, normal structural movement and heating and cooling from seasonal weather changes

Uponor PEX provides the durability and reliability that is needed for these applications and currently holds the unofficial world record for long-term testing at elevated temperature and pressure. From 1973 to 2009, the pipe was subjected to ongoing testing at 203°F (95°C) at 175 psi by Studvik in Sweden and BASF in Germany.

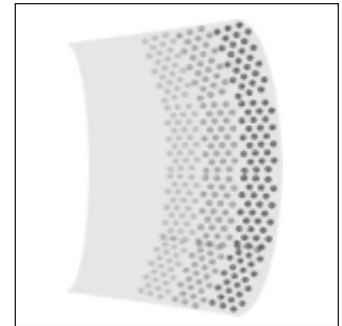

Figure 1-3: PEX-c (Radiation) 70-75% crosslinked

Cleanliness of Uponor PEX

The quality materials and exacting process used in manufacturing Uponor AquaPEX® yield remarkably clean water-distribution piping. Uponor PEX piping is made by crosslinking high-density, high-molecular weight, 100% virgin polyethylene flake. It is subject to the highest testing, codes, listings and standards.

In addition to testing and certification at NSF International, Canadian Standards Association (CSA) and Underwriters Laboratories (UL), Uponor PEX piping has been tested and approved for potable-water applications by the most demanding agencies in the world, including DVWG-Germany, KIWA-Netherlands, CTSB-France and BSI-Great Britain.

Toxicity extraction testing performed in accordance with ANSI/NSF 61 Drinking Water System Components — Health Effects verifies Uponor PEX piping does not leach potentially harmful substances into the drinking water.

Ultraviolet (UV) resistance

The test method for evaluating UV resistance as required by ASTM F876 is ASTM F2657 *Test Method for Outdoor Weathering Exposure of Cross-linked Polyethylene*

(PEX). According to ASTM F876, PEX piping must bear a four-digit code to signify the requirements it meets. The second digit in the code references the minimum ultraviolet (UV) resistance of the piping. For example,

piping with a 5106 marking has a “1” as the second digit, which indicates the piping meets minimum UV resistance requirements for a period of 1 month. Piping with a “2” as the second digit indicates a resistance period of 3 months, and piping with a “3” indicates a resistance period of 6 months.

For the minimum UV resistance of all Uponor AquaPEX products, refer to **Table 1-1**.

Note: See **page 87** for handling guidelines regarding light fixtures.

Chemical resistance

PEX has very good resistance to chemical-dissolving agents. The unique molecular structure is stable and inert, and it is virtually unaffected by chemicals (organic or inorganic) commonly found in plumbing systems. Contact Uponor Technical Support for specific chemical compatibility verification. Review the Plastics Pipe Institute (PPI) Technical Report 19 *Chemical Resistance of Thermoplastics Piping Materials* for more information about the transport of chemicals.

Oxidative resistance

The test method for evaluating oxidative resistance as required by ASTM F876 is ASTM F2023 *Test Method for Evaluating the Oxidative Resistance of Cross-linked Polyethylene (PEX) Piping and Systems to Hot Chlorinated Water*. According to ASTM F876, PEX piping must bear a four-digit code to signify the requirements it meets. The first digit in the code references the minimum chlorine resistance at end-use conditions.

Uponor AquaPEX was evaluated according to the ASTM F2023 test method for evaluating oxidative resistance to hot, chlorinated water. This is the most stringent test method in the industry. Uponor AquaPEX piping exceeds the minimum life expectancy requirement of 50 years when operating with end-use conditions of 100% recirculation at 140°F/60°C for potable water. Refer to **page 55** for proper hot-water system design.

Product	Marking	UV resistance
Uponor AquaPEX White	5106	1 month
Uponor AquaPEX Blue	5306	6 months
Uponor AquaPEX Red	5306	6 months

Table 1-1: Uponor AquaPEX® UV resistance ratings

Note: Uponor AquaPEX purple reclaimed water pipe has not been tested for UV resistance and therefore retains a 5006 rating.

Property	English units	SI units
Approximate modulus of elasticity (Secant at 1% and 1% and 73°F/22.8°C)	91,350 psi	630 N/mm ²
Tensile yield strength at 68°F (20°C) per DIN 53455	2.76-3.77 psi	19-26 N/mm ²
Piping density	59 lbs./ft ³	936 Kg/m ³
Impact strength	Will not fail under impact at temperatures of -284°F/-140°C	
Water absorption	Room temperature = 0.01% Boiling for 40 days = 0.07%	
Coefficient of friction (surface-roughness factor)	0.000019 inches	0.0005 mm
Surface tension	0.00014 lbs./inches	25 dyne/cm
Recommended working-temperature limits	-58°F to 200°F	-50°C to 93°C
Short-term maximum temperature	210°F	99°C
Coefficient of linear expansion at 135°F/57°C	Ave. = 9.2*10 ⁻⁵ in/in-°F	Ave. = 1.7*10 ⁻⁴ m/m-°C
Softening temperature	264°F to 268°F	129°C to 131°C
Specific heat	0.55 Btu/lb-°F	2302.3 J/kg-°C
Coefficient of thermal conductivity	0.219 Btu/(hr·ft·°F)	0.38 W/(m·°K)
Degree of crosslinking	70 to 89% (per ASTM F876)	
Minimum bend radius	Six times the outside diameter	

Table 1-2: Material properties of Uponor AquaPEX piping

Dimensions and physical characteristics of SDR9 Uponor PEX pipe					
Nominal pipe size	Pipe O.D. (in)	Pipe I.D. (in)	Weight of pipe only lbs/ft (kg/m)	Contents of pipe gal/ft (l/m)	Weight of pipe and water lbs/ft (kg/m)
¼"	0.375	0.241	0.04 (0.018)	0.0024 (0.009)	0.06 (0.027)
⅜"	0.50	0.350	0.05 (0.022)	0.005 (0.018)	0.09 (0.040)
½"	0.625	0.475	0.06 (0.027)	0.0092 (0.034)	0.14 (0.063)
⅝"	0.750	0.574	0.08 (0.036)	0.0134 (0.050)	0.19 (0.086)
¾"	0.875	0.671	0.1 (0.045)	0.0184 (0.069)	0.25 (0.113)
1"	1.125	0.862	0.2 (0.090)	0.0303 (0.114)	0.45 (0.204)
1¼"	1.375	1.054	0.34 (0.154)	0.0453 (0.171)	0.72 (0.326)
1½"	1.625	1.244	0.44 (0.199)	0.0632 (0.239)	0.96 (0.435)
2"	2.125	1.629	0.682 (0.309)	0.1083 (0.409)	1.58 (0.716)
2½"	2.625	2.011	0.93 (0.421)	0.1649 (0.624)	2.3 (1.043)
3"	3.125	2.4	1.28 (0.580)	0.2351 (0.889)	3.24 (1.469)

Table 1-3: Dimensions and physical characteristics of SDR9 PEX pipe

Hydrostatic temperature and pressure ratings

Through scientific research and historical experience, hydrostatic design basis (HDB) ratings have been shown to be useful indicators of relative long-term strength of thermoplastic materials when tested under the conditions specified in test method ASTM D2837. The HDB is used to determine the temperature and pressure ratings of a specific material. These temperature and pressure ratings are based on an extrapolated life of 50 years.

Standard PPI TR-3 defines the policies and procedures for developing HDB ratings for thermoplastic piping materials or pipe.

Uponor maintains standard-grade ratings for Uponor AquaPEX piping as tested in accordance with TR-3. Uponor AquaPEX carries the following temperature and pressure ratings shown in **Table 1-4**.

Note: Uponor engineered polymer (EP) and lead-free (LF) brass fittings carry the same temperature and pressure ratings as Uponor AquaPEX pipe.

Interpolation method

Pressure ratings at different temperatures are determined by using a linear relationship between the standard-grade ratings. See **Table 1-5** for interpolated temperature and pressure ratings.

Excessive temperature and pressure capability

In accordance with ASTM F876 *Standard Specification for Cross-linked Polyethylene (PEX) Piping*, the excessive temperature and pressure capability of Uponor AquaPEX is 210°F at 150 psi (99°C at 10 bar).

This standard requires that Uponor AquaPEX piping maintain its integrity for a period of 720 hours (30 days) at 210°F at 150 psi (99°C at 10 bar). If installed as directed, Uponor AquaPEX will withstand these conditions.

Note: Excessive temperature and pressure requirements are always subject to approval by local building codes (e.g., temperature and pressure-relief valves).



Temperature and pressure ratings	
°F/°C	psi/bar
200.0/93.3	80/5.5
190.0/87.8	90/6.2
180.0/82.2	100/6.9
170.0/76.7	106/7.3
160.0/71.1	111/7.7
150.0/65.6	117.8.0
140.0/60.0	123/8.5
130.0/54.4	128/8.8
120.0/48.9	134/9.2
110.0/43.3	139/9.6
100.0/37.8	145/10.0
90.0/32.2	151/10.4
80.0/26.7	156/10.8
73.4/23.0	160/11.0
60.0/15.6	168/11.6
50.0/10.0	173/11.9
40.0/4.4	179/12.3

Table 1-5: Interpolated hydrostatic temperature and pressure ratings for Uponor AquaPEX piping

ASTM F876 temperature and pressure ratings for SDR9 PEX

Rated temperature	Hydrostatic design stress (HDS) psi	Pressure rating for water psi
73.4°F/23°C	630	160
180°F/82°C	400	100
200°F/93°C	315	80

Table 1-4: Hydrostatic temperature and pressure ratings for Uponor AquaPEX piping

These listings are published in PPI TR-4, a culmination report of the listings that are maintained with PPI.

Standards, codes and listings

Uponor AquaPEX piping is manufactured to meet the following requirements.

Standards

ASTM International

- ASTM F876 *Standard Specification for Cross-linked Polyethylene (PEX) Piping*
- ASTM F877 *Standard Specification for Cross-linked Polyethylene (PEX) Plastic Hot- and Cold-Water Distribution Systems*
- ASTM F1960 *Standard Specification for Cold Expansion Fittings with PEX Reinforcing Rings for Use with Cross-linked Polyethylene (PEX) Piping*
- ASTM F2023 *Standard Test Method for Evaluating the Oxidative Resistance of Cross-linked Polyethylene (PEX) Piping and Systems to Hot Chlorinated Water*
- ASTM F2657 *Standard Test Method for Outdoor Weathering Exposure of Cross-linked Polyethylene (PEX) Piping*
- ASTM E84 *Standard Test Method for Surface Burning Characteristics of Building Materials*
- ASTM E119 *Standard Test Methods for Fire Tests of Building Construction and Materials*
- ASTM E814 *Standard Test Method for Fire Tests of Through-Penetration Firestop Systems*

NSF International

- ANSI/NSF *Standard 14 Plastics Piping System Components and Related Materials*
- ANSI/NSF *Standard 61 Drinking Water System Components — Health Effects*
- ANSI/NSF *Standard 359 Valves for Crosslinked Polyethylene (PEX) Water Distribution Systems*

American Water Works Association (AWWA)

- AWWA C904 *Cross-Linked Polyethylene (PEX) Pressure Pipe, ½" (12mm) through 3" (76mm) for Water Service*

Underwriters Laboratories, Inc. (UL)

- ANSI/UL 263 *Standard for Safety for Fire Tests of Building Construction and Materials*
- UL 1821 *Standard for Safety for Thermoplastic Sprinkler Pipe and Fittings for Fire Protection Service (NFPA 13D applications only)*
- UL 2846 *Standard for Safety for Fire Test of Plastic Water Distribution Plumbing Pipe for Visible Flame and Smoke Characteristics*

CSA Group (Canadian Standards Association)

- CAN/CSA B137.5 *Crosslinked Polyethylene (PEX) Piping Systems for Pressure Applications*
- CAN/CSA B214 *Installation Code for Hydronic Heating Systems*

American Society of Mechanical Engineers (ASME)

- ASME B16.5 *Pipe Flanges and Flanged Fittings: NPS ½ through NPS 24 Metric/ Inch Standard*

Underwriters Laboratories of Canada (ULC)

- CAN/ULC-S102.2 *Standard Method of Test for Surface Burning Characteristics of Flooring, Floor Covering and Miscellaneous Materials and Assemblies*
- CAN/ULC-S101 *Standard Methods of Fire Endurance Tests of Building Construction and Materials*
- CAN/ULC-S115 *Standard Method of Fire Tests of Firestop Systems*
- CAN/ULC/ORD-C199P *Combustible Piping for Sprinkler Systems*

Plastics Pipe Institute (PPI)

- PPI Technical Report TR-4

Codes

- ICC
- IPC
- IMC
- IRC
- UPC
- UMC
- NSPC
- HUD
- UFGS
- NPC of Canada
- NBC of Canada

Listings

- cNSFus-fs
- cNSFus-rfh
- cNSFus-pw
- cQAlus
- UL
- CSA
- WH
- ETL
- PPI TR-4
- ICC-ES-PMG
- IAPMO
- BMEC
- CCMC

ProPEX® fittings

Uponor ProPEX® fittings are available in both EP and LF brass and are tested and listed to:

- ASTM F1960 *Standard Specification for Cold Expansion Fittings with PEX Reinforcing Rings for Use With Cross-linked Polyethylene (PEX) Piping*
- CAN/CSA B137.5 *Crosslinked Polyethylene (PEX) Piping Systems for Pressure Applications*

Uponor ProPEX EP fittings

Accessibility

Based on Uponor's review of the International Plumbing Code (IPC), National Plumbing Code of Canada (NPCC) and Uniform Plumbing Code (UPC), there are no requirements for direct access to Uponor ProPEX fittings (i.e., ASTM F1960 and CAN/CSA B137.5). Thus, ProPEX fittings (which includes Uponor's multport tees) may be placed behind drywall or other coverings without the need for openings or similar means of direct access to the fittings. However, codes require that an operating valve must be accessible. Thus, a valve or similar operable component that incorporates Uponor ProPEX connections must be accessible.

Performance

EP is a high-performance thermoplastic material that has superior mechanical, chemical and thermal properties which provide dimensional stability in demanding applications, including areas of high stress, heat and moisture.

Uponor EP fittings comply with NSF/ANSI 61 health effects requirements when tested at temperatures up to and including 180°F/82.2°C (i.e., commercial hot water).

Durable

Resistant to corrosion, pitting and scaling, Uponor EP products are designed for any plumbing — and even heating — application, whether residential or commercial.

Note: Do not expose EP fittings to direct sunlight for more than 30 days.

Lead free

EP fittings are the ideal solution to lead-free requirements and are even approved for direct burial in soil, making installation options endless.

Cost effective

Uponor EP is a more cost-effective option because it offers a stable material cost and is not subject to the wide price fluctuations of metal.



Couplings



Elbows



Tees



Plugs

Multiport tees



The strength of Uponor EP

Uponor EP is made from UDEL® polysulfone, Radel R® polyphenylsulfone or Acudel® modified polyphenylsulfone. These materials are part of a family of polymers that have been used successfully in the demanding environments of medical appliance, aerospace and plumbing for many years. In fact, lab tests prove the Uponor 2" ProPEX EP Tee and ProPEX connection are able to withstand up to 2,900 lbs. of pull force without failure.



Figure 1-4: Beginning of test



Figure 1-5: At approximately 2,900 lbs. of pull force



Uponor ProPEX LF brass fittings

Uponor offers a complete line of LF brass transition fittings, valves, stub-outs, water-heater connectors and wall boxes.

- All Uponor LF brass products comply with NSF/ANSI 61 Annex G, NSF/ANSI 372 and conform to the lead-content requirements for “lead-free” plumbing as defined by California, Vermont, Maryland and Louisiana state laws as well as the U.S. Safe Drinking Water Act, effective January 2014.

- All Uponor LF brass fittings marked as NSFus-pw-G comply with the dezincification resistance (DZR) and stress-corrosion cracking (SCC) requirements of Sections 5.8.1 and 5.8.2 per the current NSF 14 Standard.
- Uponor’s LF brass is approved for direct burial in soil per NSF/ANSI Standard 14 testing which established minimum performance criteria for DZR/SCC resistance for PEX fittings intended for potable water.

Soldering

- When soldering LF brass fittings, Uponor recommends using a lead-free flux and solder which meet the requirements of NSF/ANSI 372 or NSF/ANSI 61 Annex G. Please refer to the solder and flux manufacturer for details on properly soldering lead-free brass materials.

Fittings by others

Uponor PEX piping can be used with any type of SDR9 PEX fitting, including compression fittings. Compression fittings must be installed with an insert stiffener to ensure the pipe wall doesn’t collapse under compression, compromising the connection.

Note that Uponor cautions the use of other manufacturer’s PEX pipe with Uponor ProPEX rings as well as using other’s expansion rings with Uponor PEX pipe. Because of the lower degree and uniformity of crosslinking in PEX-b and PEX-c pipe, stress cracking of the PEX-b and PEX-c pipe wall can occur during expansion, compromising the strength of the fitting connection. Additionally, the 25-year limited warranty for Uponor PEX systems is only valid when using both Uponor PEX pipe and Uponor

ProPEX fittings. Mixing Uponor ProPEX rings with other manufacturers’ PEX pipe or other manufacturers’ expansion rings with Uponor PEX pipe will limit the warranty. For complete warranty details, refer to uponorpro.com/warranties.

Note: When transitioning from copper to PEX, Uponor recommends the use of ProPEX LF brass copper press adapters. Standard Uponor LF brass sweat adapters cannot be pressed as they are a different material.

Chapter 2: Making ProPEX connections

Uponor ProPEX ASTM F1960 (CAN/CSA B137.5) cold-expansion fittings make solid, permanent, manufactured connections without the need for torches, glues, solder, flux or gauges. The unique shape memory of Uponor PEX piping forms a tight seal around the fitting, creating a strong, reliable connection.

This document shows how to make proper ProPEX connections using one of the following tools.

- Milwaukee® M12™ or M18™ ProPEX expansion tools
- Milwaukee M18 FORCELOGIC™ ProPEX Expansion Tool
- ProPEX 201 Corded Expander Tool
- ProPEX Hand Expander Tool

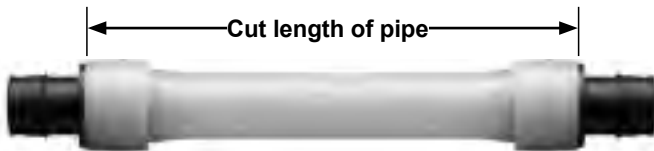

Distance between fittings

Uponor requires a minimum distance between ProPEX fittings to avoid damaging the fittings during installation and to protect against elevated stress on the pipe and fittings. Refer to **Table 2-1** for the minimum distance between fittings, which is expressed as cut length of pipe.

Nominal fitting size	Cut length of pipe
½"	2"
¾"	3"
1"	3½"
1¼"	4½"
1½"	4½"
2"	6"
2½"	7½"
3"	9"

Table 2-1: Minimum distance between ProPEX fittings

Piping size	Milwaukee ProPEX tool			Uponor ProPEX tool		
	M12	M18	FORCELOGIC	Manual	100/150	201
¾"	8	9	—	5	7	—
½"	5	6	—	4	4	—
¾"	9	8	—	9	9H	—
1"	12	5	—	14	7H	—
1¼"	—	7	—	—	7H	—
1½"	—	6	—	—	8H	—
2"	—	—	4	—	—	5H
2½"	—	—	5	—	—	—
3"	—	—	7	—	—	—

Table 2-2: Recommended number of expansions for ¾" to 3" piping at 73.4°F (23°C)

Note: "H" in the table refers to Uponor H-series expander heads.



General ProPEX connection tips

- If the fitting does not slide into the piping all the way to the stop, immediately remove it from the piping and expand the piping one final time.

Note: To avoid over-expanding the piping, do not hold the piping in the expanded position.

- **Table 2-2** shows the recommended number of expansions. Experience, technique and weather conditions influence the actual number of expansions. Fewer expansions may be necessary under certain conditions. The correct number of expansions is the amount necessary for the piping and the shoulder of the fitting to fit snugly together.

- Ensure the ProPEX ring rests snugly against the fitting shoulder. If there is more than ¼" (1mm) between the ring and the shoulder of the fitting, the connection must be replaced. Square cut the piping 2" away from the fitting for ½" to 1" pipe, 3" away for 1¼" to 2" pipe and 5" away for 2½" and 3" pipe prior to making the new connection.
- Brass ProPEX fittings can be disconnected and reused. EP fittings must be discarded. Be sure to follow the recommended minimum distance between ProPEX fittings shown in **Table 2-1**.



Making ProPEX connections with Milwaukee M12 or M18 ProPEX expansion tools

Note: All standard Uponor expander heads are compatible with the M12 and M18 tools. Uponor expander heads will not auto-rotate on the Milwaukee tools (only Milwaukee expansion heads will auto-rotate on the M12 and M18). H-heads are not compatible with Milwaukee tools and Milwaukee heads are not compatible with Uponor tools. Milwaukee heads are easily distinguished by color coding and the Milwaukee logo.



3/8" and 1/2" Milwaukee expansion head



3/4" to 3" Milwaukee expansion head

Important! Making expansions are slightly different when using a tool that features auto rotation. When making a ProPEX connection, be sure to follow the guidelines for the tool you are using in your application.

1. Square cut the PEX piping perpendicular to the length of the piping. Remove all excess material or burrs that might affect the fitting connection.
2. Slide the ProPEX ring over the end of the piping until it reaches the stop edge. If using a ProPEX ring without a stop edge, extend the ring over the end of the piping no more than 1/16" (1mm).

Important! If making a 3/8" ProPEX connection, first expand each side of the ring before placing it on the piping. Refer to the "Making 3/8" ProPEX connections" instructions on **page 14** for further information.

With auto rotation (standard Milwaukee heads)

3. Milwaukee ProPEX expansion tools come with built-in auto rotation. If using a Milwaukee expansion head, simply hold the piping and tool in place while holding the trigger to expand the piping. The head will automatically rotate to ensure the piping is evenly expanded. Continue expanding and rotating until the piping and ring are snug against the shoulder on the expander head. See **Table 2-2** for the recommended number of expansions for each piping size.

Note: Do not force the pipe onto the expander head. Ensure the expander head is rotating during each expansion.

Without auto rotation (standard Uponor heads)

4. Press the trigger to expand the piping.
5. Release the trigger, remove the head from the piping, rotate it 1/8 turn and slide the head back into the piping. Continue expanding and rotating until the piping and ring are snug against the shoulder on the expander head. See **Table 2-2** for the recommended number of expansions.

Important! Rotating the tool between expansions will provide smooth, even expansion of the piping. Failure to rotate the tool will cause deep grooves in the piping which can result in potential leak paths.



Expansion with Milwaukee M12 ProPEX Expansion Tool



ProPEX coupling



ProPEX tee

Insert ProPEX fitting into 1/2" Uponor PEX piping.

Insert ProPEX fitting into 1" Uponor PEX piping.

6. After the final expansion, immediately remove the tool and insert the fitting. Ensure the piping and ring seat against the shoulder of the fitting.

Important! Only perform the necessary number of expansions. DO NOT over expand the pipe. You should feel some resistance as the fitting goes into the piping. If you do not feel any resistance, the piping may be over expanded and will require additional time to shrink over the fitting.



Expansion with Milwaukee M18 ProPEX Expansion Tool

Making ProPEX connections with Milwaukee M18 FORCELOGIC ProPEX expansion tools



FORCELOGIC expansion head installation

The Milwaukee FORCELOGIC ProPEX Expansion Tool for 2", 2½" and 3" Uponor PEX pipe features an auto-rotating head with specially designed alignment cogs. This requires slightly different head installation than the M12 and M18 ProPEX expansion tools for ¾" to 1½" pipe sizes.

1. Remove the battery pack and place the FORCELOGIC tool in the upright position (cone up).
2. Verify the expansion cone is fully retracted.
3. Screw the head onto the tool (clockwise). Hand-tighten securely. Do not over tighten. Ensure the expansion head fits flush against the tool.
4. Check the installation.
 - a. Ensure the head segments do not "flower" (see **image 4a**).
 - b. If the head flowers, correct the installation by loosening the head slightly and rotating the segments until they engage in the cogs. Re-tighten the head.
 - c. Rotate the six expansion segments in the clockwise direction. They will rotate freely. They should not rotate counterclockwise.
 - d. The expansion head collar will fit flush against the tool.



Auto-rotate teeth

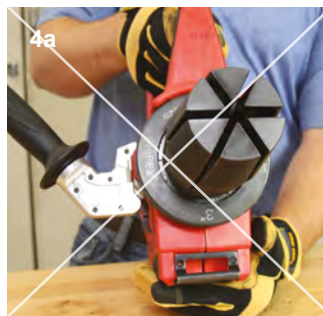

Incorrect expansion head "flowering"



Correct expansion head alignment

Making a ProPEX connection

1. Square cut the PEX piping perpendicular to the length of the piping. Remove all excess material or burs that might affect the fitting connection.
2. Slide the ProPEX ring over the end of the piping until it reaches the stop edge.
3. The Milwaukee tool comes with built-in auto rotation, meaning the head will automatically rotate to ensure the piping is evenly expanded.

Note: To cancel the expansion process quickly, pull and release the trigger.

4. Press the trigger to initiate the rotation of the head. A green light will turn on and the work light will blink. Insert the pipe and ring and release the trigger. When the expansion head has reached its maximum diameter, it will retract.

Important! Do not force the pipe and ring on the head during any expansion.

5. After the tool has retracted, the green indicator light blinks three times. Press the trigger and repeat the expansion process.

6. Repeat the process until the pipe and ring are snug against the shoulder of the expansion head. Repeat the expansion one or two more times depending on the ambient temperature.

Note: Fewer expansions are required in colder temperatures.

7. After final expansion, immediately remove the tool and insert the fitting.

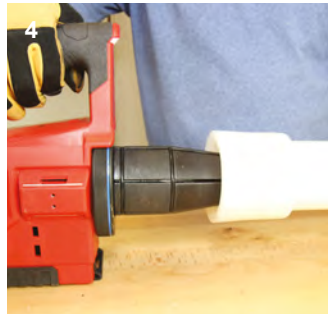

Making ProPEX connections with ProPEX 201 corded expander tools



1. Square cut the PEX piping perpendicular to the length of the piping. Remove all excess material or burrs that might affect the fitting connection.
2. Slide the ProPEX ring over the end of the piping until it reaches the stop edge. If using a ProPEX ring without a stop edge, extend the ring over the end of the piping no more than $\frac{1}{16}$ " (1mm).
3. Slide the expander head into the piping until it stops. Full expansions are necessary to make a proper connection.
4. Press the trigger to expand the piping.



5. Release the trigger, remove the head from the piping, rotate it $\frac{1}{8}$ turn and slide the head back into the piping. Continue expanding and rotating until the piping and ring are snug against the shoulder on the expander head. See **Table 2-2**.

Important! Rotating the tool between expansions will provide smooth, even expansion of the piping. Failure to rotate the tool will cause deep grooves in the piping which can result in potential leak paths.

6. After the final expansion, immediately remove the tool and insert the fitting. Ensure the piping and ring seat against the shoulder of the fitting.



Insert ProPEX fitting into 2" Uponor PEX piping.



ProPEX EP tee inserted into 2" Uponor PEX piping



ProPEX 2" brass fitting inserted into Uponor PEX piping

Making 3/8" ProPEX connections

When making a 3/8" ProPEX connection, expand the ring once on each side to properly fit over the piping. Refer to the following instructions to make a 3/8" ProPEX connection.

1. Square cut the PEX piping perpendicular to the length of the piping. Remove all excess material or burrs that might affect the fitting connection.
2. Expand each side of the ring once.
3. Slide the expanded ring over the end of the piping. Extend the end of the ring over the end of the piping no more than 1/16" (1mm).
4. After the ring is on the piping, continue with the regular steps for making a proper connection with your specific tool.



E6081128 pipe cutter (plastic)

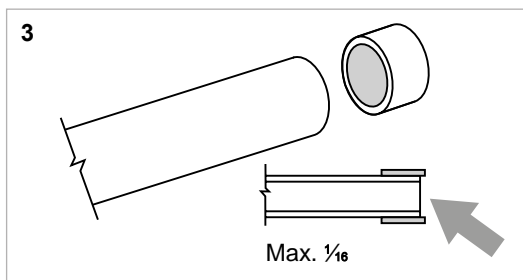
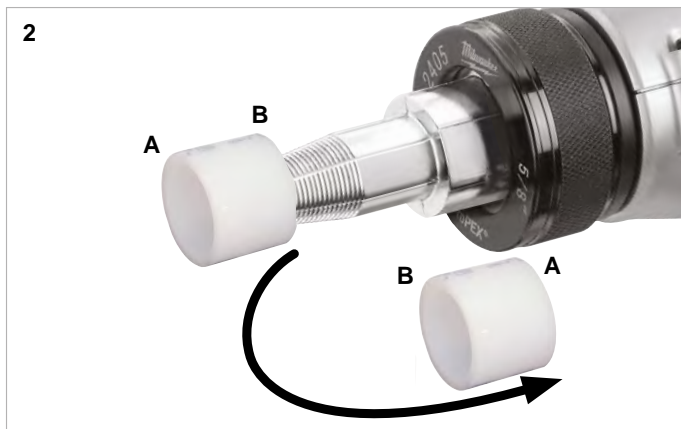

Proper expander tool and head maintenance

- Use a lint-free cloth to apply a light coat of lubricant to the cone prior to making any ProPEX connections.
- If used regularly, apply the lubricant daily to the cone of the ProPEX expander tool. Failure to keep the tool lubricated may result in improper connections.



Caution: Excessive lubrication may result in improper connections. Only use a small amount of lubrication to keep the tool working properly.

- Keep all other parts of the tool free from lubricant.
- Once a month, soak the heads in degreasing agent to remove any grease from between the segments. Clean the cone using a clean, dry cloth.

Important tips for a proper 3/8" ProPEX connection

- The thicker 3/8" ProPEX Ring shrinks over the fitting faster than larger-sized rings.
- When the temperature is below 40°F (4.4°C), fewer expansions are required.

Disconnecting a ProPEX brass fitting

ProPEX brass and EP fittings are manufactured connections that can be concealed in walls, ceilings and floors. When necessary, ProPEX brass fittings can be disconnected.

Important! EP fittings cannot be reclaimed.

Refer to the following guidelines for disconnecting a ProPEX brass fitting.

1. Ensure the system is not pressurized.
2. Use a utility knife to carefully cut through the ProPEX ring.

Important! Do not heat the ring prior to cutting it. Take care to cut only the ring and not the piping or fitting. Gouges in the fitting may result in leaks. If you accidentally damage the fitting, you must discard it.

3. Remove the ProPEX ring from the piping.
4. After removing the ring, apply heat directly around the fitting and piping connection.
Do not use open flame. Gently work the piping back and forth while pulling slightly away from the fitting until the piping separates from the fitting.
5. After removing the fitting, measure:
2" (50.8mm) minimum for $\frac{3}{8}$ " to 1" pipe
3" (76.2mm) minimum for 1 $\frac{1}{4}$ " to 2" pipe
5" (127mm) minimum for 2 $\frac{1}{2}$ " and 3" pipe
6. Square cut the piping at the proper marking.
7. Allow the fitting to cool before making the new connection.
8. Use a new ProPEX ring and follow the steps to make a new connection.



Troubleshooting ProPEX connections

Trouble-free ProPEX installations begin with a tool that is maintained in proper working condition. If the tool or segment fingers are damaged, it is very difficult to make a proper connection. Refer to the following guidelines to assist with challenges in the field.

Fittings won't seal

- Make sure the expander head is securely tightened onto the tool.
- Ensure the segment fingers are not bent. If the head does not completely close when the drive unit is fully retracted or the handles of the manual tool are open, replace the head.
- Examine the tool for excess grease on the segment fingers. Remove excess grease prior to making connections.
- Check the fitting for damage. Nicks and gouges will cause the fitting to leak.
- Make sure the internal driver cone is not damaged or bent.
- Make sure the last expansion is not held in the expanded position before the fitting is inserted. You should feel some resistance as the fitting goes into the piping. If you do not feel any resistance, the piping may be over expanded and will require additional time to shrink over the fitting.
- Be sure to rotate the tool $\frac{1}{8}$ turn after each expansion to avoid deep grooves in the piping which can result in potential leak paths.

Expansion is difficult

- Make sure the internal cone is properly greased.

Expansion head slips out of piping when making expansions

- Ensure the piping and ProPEX ring are dry.
- Make sure that grease is not getting into the piping.
- Examine the segment fingers to ensure they are not damaged or bent.

ProPEX ring slides down piping during expansion

- Ensure your hands are clean while handling the piping. Any sweat or oils on your hands can act as a lubricant. Due to the smoothness of PEX, any form of lubricant can cause the ProPEX ring to slide down the piping during expansion.
- If you anticipate the ProPEX ring may possibly slide down, position the ring slightly farther over the end of the piping and make the first couple of expansions slowly. Once the ring and the piping begin to expand together, continue with the normal number and type of expansions.
- Place your thumb against the ProPEX ring to help support it and feel for any movement. If caught early, you can slide the ring up the piping and expand as described in the previous bullet point.

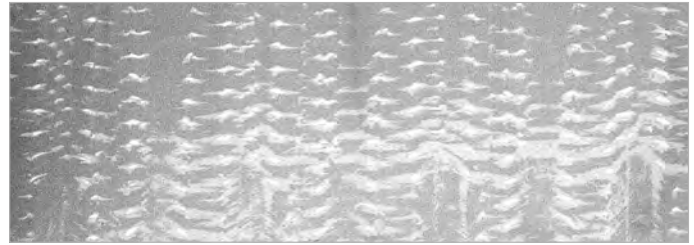

Expansion with proper rotation

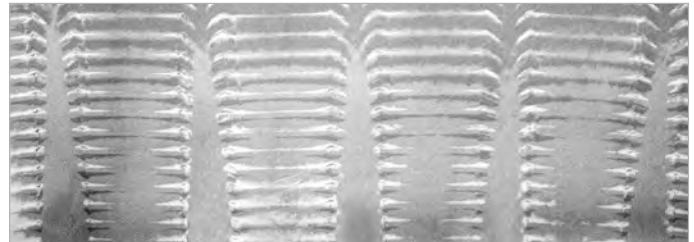

Expansion without proper rotation

More than the recommended number of expansions are needed to make a connection

- Ensure the head is hand-tightened to the expander tool.
- Examine the segment fingers for damage.
- Be sure to completely cycle the tool on each expansion (i.e., close the manual tool handle or release the trigger).

Cold-weather expansions

- Temperatures affect the time required for the piping and ring to shrink onto the fitting. The colder the temperature, the slower the contraction time.
- Warming ProPEX fittings and ProPEX rings reduces contraction time. Put fittings and rings in your pockets prior to installation to keep them warm.
- Fewer expansions are necessary in temperatures below 40°F (4.4°C).

Note: Do not use a heat gun on EP fittings to speed up the contraction time as this could result in damage to the fitting.

Chapter 3:

Fire-resistant construction

Wood-frame wall assemblies

Wood-frame wall assemblies complying with ASTM E119 and CAN/ULC-S101 have the following requirements.

Building elements

- Studs: Nominal wood 2x4 spaced 16" on center (o.c.)
- Gypsum wallboard: Minimum one layer of 5/8" Type X gypsum wallboard

Pipe and fittings

- Pipe: Maximum density of Uponor PEX pipe is 4.85 lbs. per linear feet (7.23 kg/m) of cavity. Approved Uponor PEX pipes include:

- Uponor AquaPEX White (up to 3")
- Uponor AquaPEX Red (up to 1")
- Uponor AquaPEX Blue (up to 1")
- Uponor AquaPEX Reclaimed Water (up to 2")
- Pre-insulated Uponor AquaPEX (up to 2" pipe with 1½" thick insulation)
- Wirsbo hePEX™ (up to 4")

- Fittings: Maximum density of Uponor ProPEX brass or EP fittings is 3.33 lbs. (1.51 kg) per stud cavity.

Note: See assembly details for more information.

Assembly numbers

ITS Design No. UW/WA 60-02

- 1-hour
- Up to 2" PEX

QAI Design No. P321-1B

- 1-hour
- Up to 4" PEX

QAI Design No. P321-1H

- 2-hour
- Up to 4" PEX

UL Design No. U372

- 1-hour
- Up to 2" PEX

Note: Maximum size is available through QAI.

Wood-frame floor/ceiling assemblies

Wood-frame floor/ceiling assemblies complying with ASTM E119 and CAN/ULC-S101 have the following requirements.

Building elements

- Joists: Nominal 2x10 solid sawn wood, open-web wood or wood I-joist (10" to 24" depth) installed at 24" o.c. maximum
- Subfloor: Minimum 5/8" plywood; if using optional topping, subfloor may be 5/8" oriented strand board (OSB)
- Gypsum wallboard:
 - Minimum one layer of 5/8" Type X gypsum wallboard when using solid sawn wood joists
 - Minimum two layers of 1/2" Type X gypsum wallboard when using wood I-joists (10" to 24" depth)

Pipe and fittings

- Pipe: One or more Uponor PEX piping runs 1/2" to 2"; weight of PEX piping not to exceed 0.63 lbs./ft. (0.94 kg/m) of joist cavity. Support pipe with metal clips 16" o.c. for piping up to 1" diameter or metal clips 24" o.c. for piping larger than 1" diameter.

- Fittings: Brass or EP fittings with a weight not exceeding 0.1 lbs./ft. (0.15 kg/m) per joist cavity

Note: See assembly details for more information.

Assembly numbers

ITS Design No. UW/FC 60-01

- 1-hour
- Up to 2" PEX

ITS Design No. UW/WA 60-02

- 1-hour
- Up to 2" PEX

QAI Design No. P321-1F

- 1-hour
- Up to 2" PEX

UL Design No. L557

- 1-hour
- Up to 2" PEX

ASTM E119 (ANSI/UL 263) or CAN/ULC-S101 listings

Fire-resistive assembly ratings (ASTM E119/ANSI/UL 263 and CAN/ULC-S101)				
Construction type	Assembly type	UL design no.	Intertek	QAI
Non-combustible concrete/steel	Floor/ceiling	K913	UW/FCA 120-01/-02	P321-1D (2-hr)
		G524	—	P321-1E (2-hr)
		G573	—	P321-1C (2-hr)
	Walls	V444	UW/WA 60-01	P321-1A (1-hr)
		—	—	P321-1G (2-hr)
Wood frame construction	Floor/ceiling	L557	UW/FCA 60-01	P321-1F (1-hr)
	Walls	U372	UW/FCA 60-02	P321-1B (1-hr)
		—	—	P321-1H (2-hr)

Table 3-1: ASTM E119 (ANSI/UL 263) and CAN/ULC-S101 listings

Steel/concrete wall assemblies

Steel/concrete wall assemblies complying with ASTM E119 and CAN/ULC-S101 have the following requirements.

Building elements

Studs: 3⁵/₈" steel studs spaced maximum 24" o.c.

- Gypsum wallboard: Minimum one layer of 5/8" thick Type X gypsum wallboard

Pipe and fittings

- Pipe: Maximum density of Uponor PEX pipe is 4.85 lbs. per linear feet (7.23 kg/m) of cavity. Approved Uponor PEX pipes include:

- Uponor AquaPEX White (up to 3")
- Uponor AquaPEX Red (up to 1")
- Uponor AquaPEX Blue (up to 1")
- Uponor AquaPEX Reclaimed Water (up to 2")
- Pre-insulated Uponor AquaPEX (up to 2" pipe with 2" thick insulation)
- Pre-insulated Wirsbo hePEX (up to 2" pipe with 2" thick insulation)
- Wirsbo hePEX (up to 4")

- Fittings: Maximum density of Uponor ProPEX brass or EP fittings is 3.33 lbs. (1.51 kg) per stud cavity.

Note: See assembly details for more information.

Assembly numbers

QAI Design No. P321-1A

- 1-hour
- Up to 4" PEX

QAI Design No. P321-1G

- 2-hour
- Up to 4" PEX

UL Design No. V444

- 1-hour
- Up to 4" PEX

Note: Maximum size is available through QAI.

Steel/concrete floor/ceiling assemblies

Steel/concrete floor/ceiling assemblies complying with ASTM E119 or CAN/ULC-S101 have the following requirements.

Building elements

- Concrete floor: Minimum slab thickness of 6½"
- Steel reinforcement: Various sized Grade 40 or 60 steel bars located as required by ACI-318
- Steel joists: Minimum nominal depth of 10" spaced maximum of 6'-0" o.c.
- Steel floor: Minimum 1½" depth, 22 gauge uncoated or galvanized fluted

Pipe and fittings

- Pipe: Maximum volume of Uponor PEX pipe is 14 cubic inches per 1 cubic foot (8101 cubic centimeters per 1 cubic meter). Approved Uponor PEX pipes include:

- Uponor AquaPEX White (up to 2")
- Uponor AquaPEX Red (up to 1")
- Uponor AquaPEX Blue (up to 1")
- Uponor AquaPEX Reclaimed Water (up to 2")
- Pre-insulated Uponor AquaPEX (up to 2" pipe with 2" thick insulation)
- Pre-insulated Wirsbo hePEX (up to 2" pipe with 2" thick insulation)
- Wirsbo hePEX (up to 2")

Note: See assembly details for more information.

Assembly numbers

ITS Design No. UW/FCA 120-01

- 1-hour
- Up to 2" PEX

ITS Design No. UW/FCA 120-02

- 2-hour
- Up to 2" PEX

QAI Design No. P321-1C

- 2-hour
- Up to 2" PEX

QAI Design No. P321-1D

- 2-hour
- Up to 2" PEX

QAI Design No. P321-1E

- 2-hour
- Up to 2" PEX

UL Design No. K913

- 2-hour
- Up to 2" PEX

UL Design No. G524

- 2-hour
- Up to 2" PEX

UL Design No. G573

- 2-hour
- Up to 2" PEX



Wood-frame assemblies (U.S.)

Multiport tee detail

Wood-frame floor/ceiling assembly (UL Design No. L557/QAI Design No. P321-1F)

Wood-stud wall assembly (UL Design No. U372/QAI Design No. P321-1B)

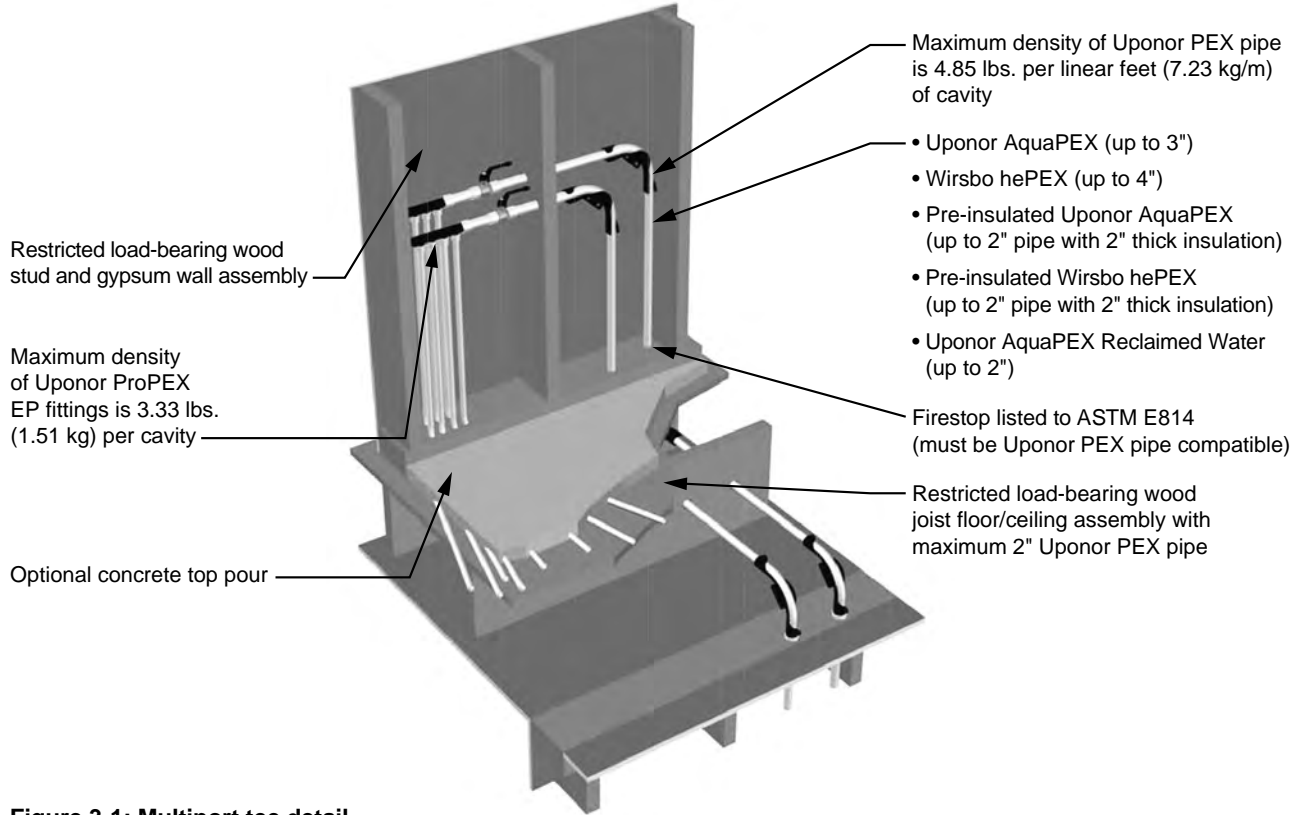

Figure 3-1: Multiport tee detail



Fixture detail 1

Wood-frame floor/ceiling assembly (UL Design No. L557/QAI Design No. P321-1F)
Wood-stud wall assembly (UL Design No. U372/QAI Design No. P321-1B)

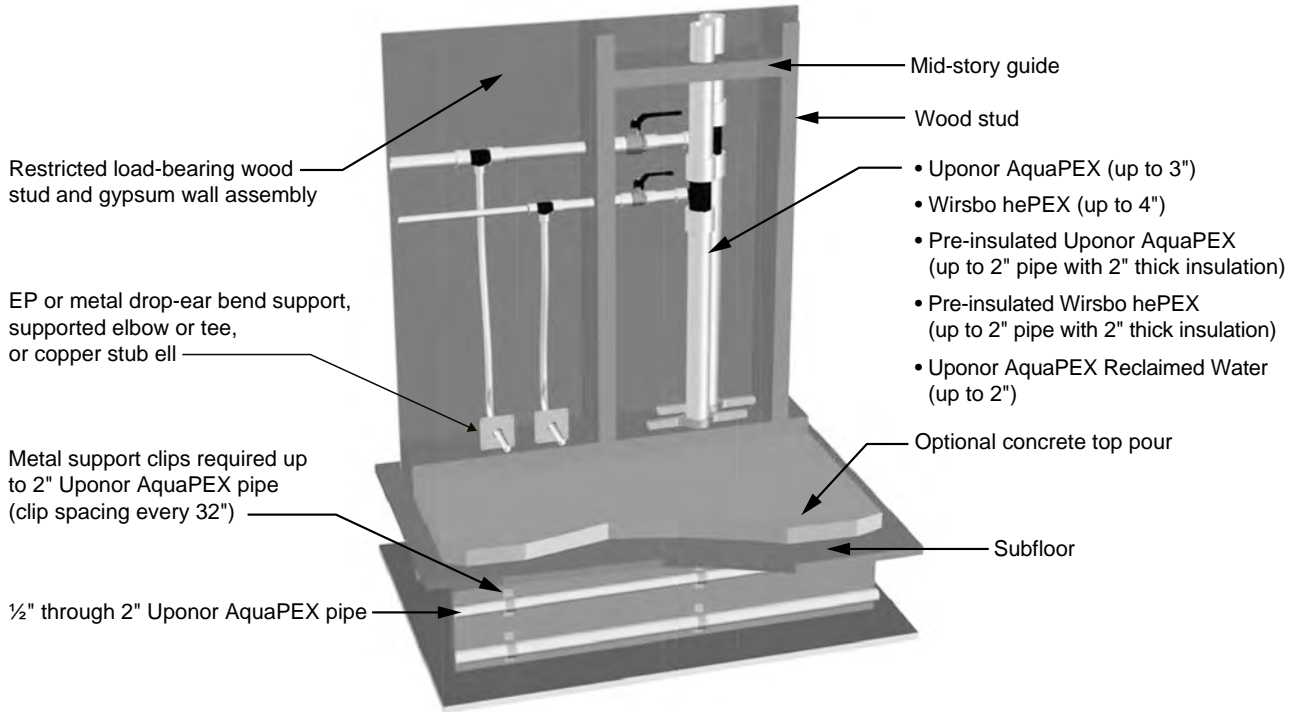

Figure 3-2: Fixture detail 1



Fixture detail 2

Wood-frame floor/ceiling assembly (UL Design No. L557/QAI Design No. P321-1F)
Wood-stud wall assembly (UL Design No. U372/QAI Design No. P321-1B)

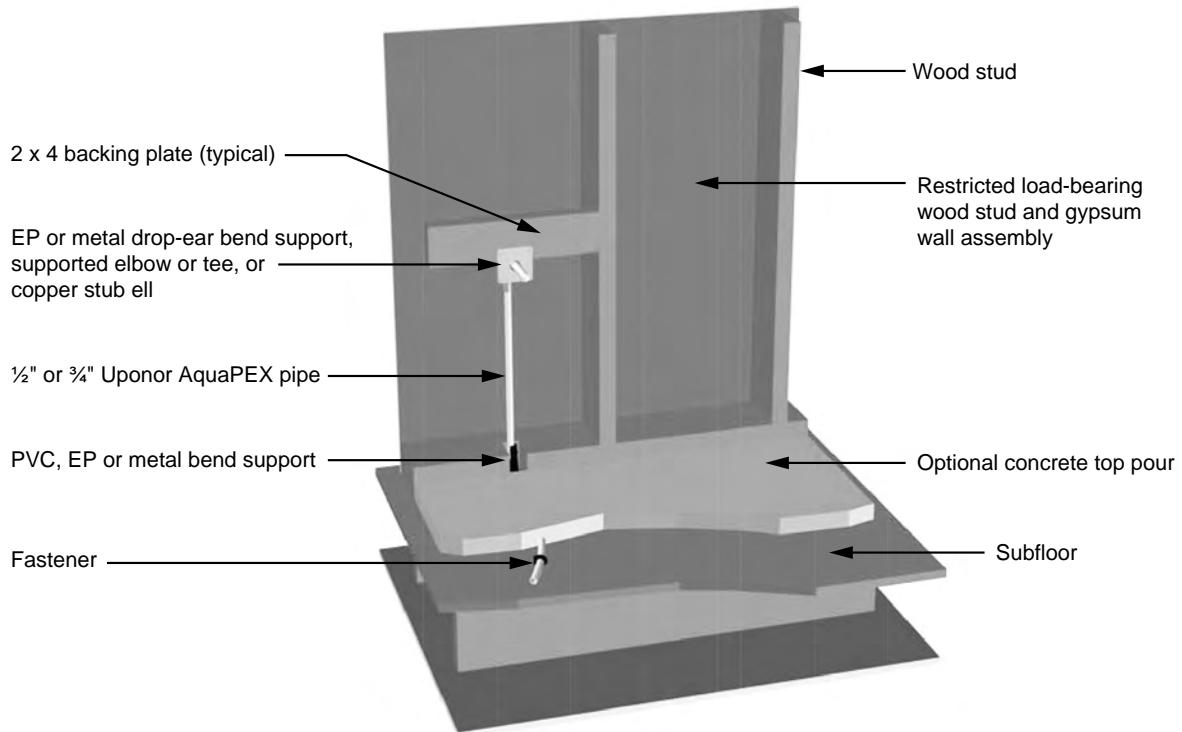

Figure 3-3: Fixture detail 2



Wood-frame assemblies (Canada)

Multiport tee detail

Wood-frame floor/ceiling assembly (ITS Design No. UW/FCA 60-01/QAI Design No. P321-1F)

Wood-stud wall assembly (ITS Design No. UW/WA 60-02/QAI Design No. P321-1B)

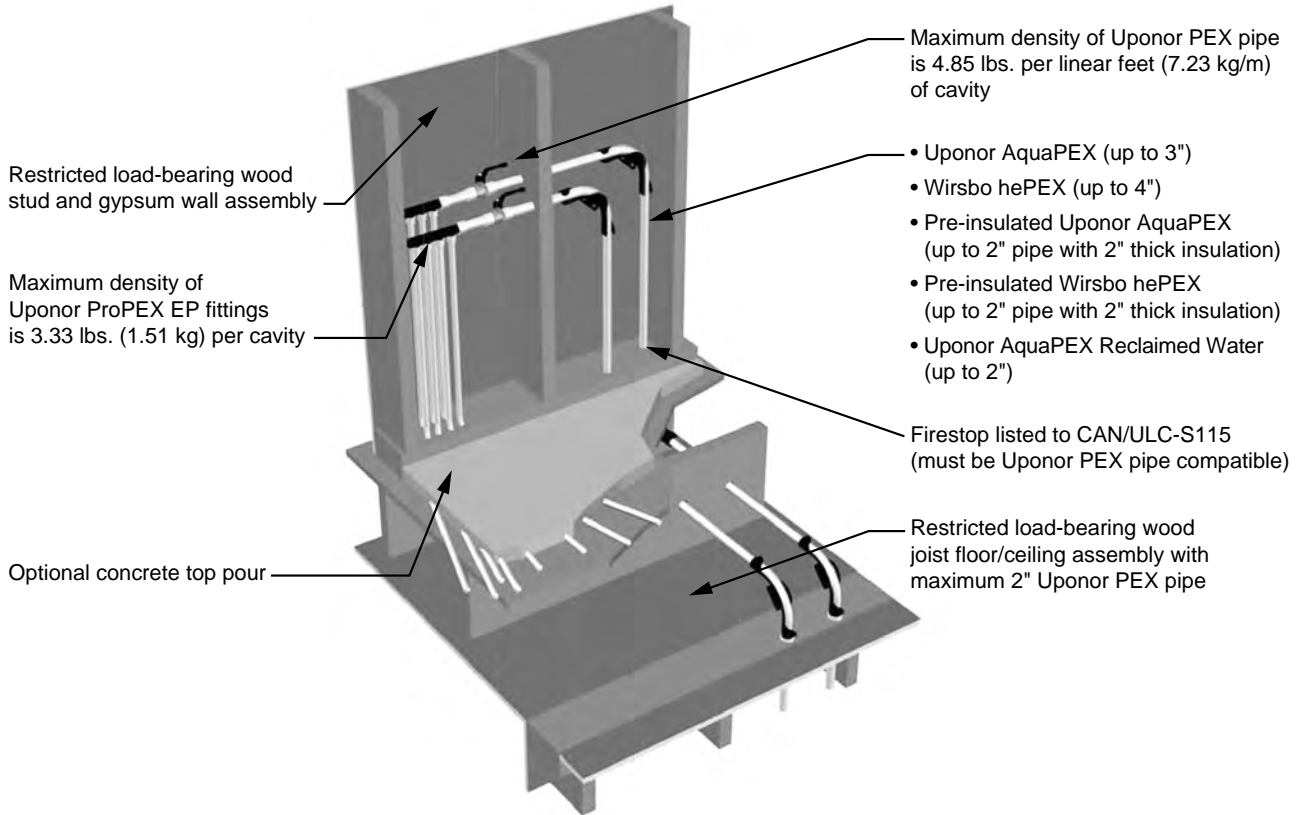

Figure 3-4: Multiport tee detail



Fixture detail 1

Wood-frame floor/ceiling assembly (ITS Design No. UW/FCA 60-01/QAI Design No. P321-1F)
Wood-stud wall assembly (ITS Design No. UW/WA 60-02/QAI Design No. P321-1B)

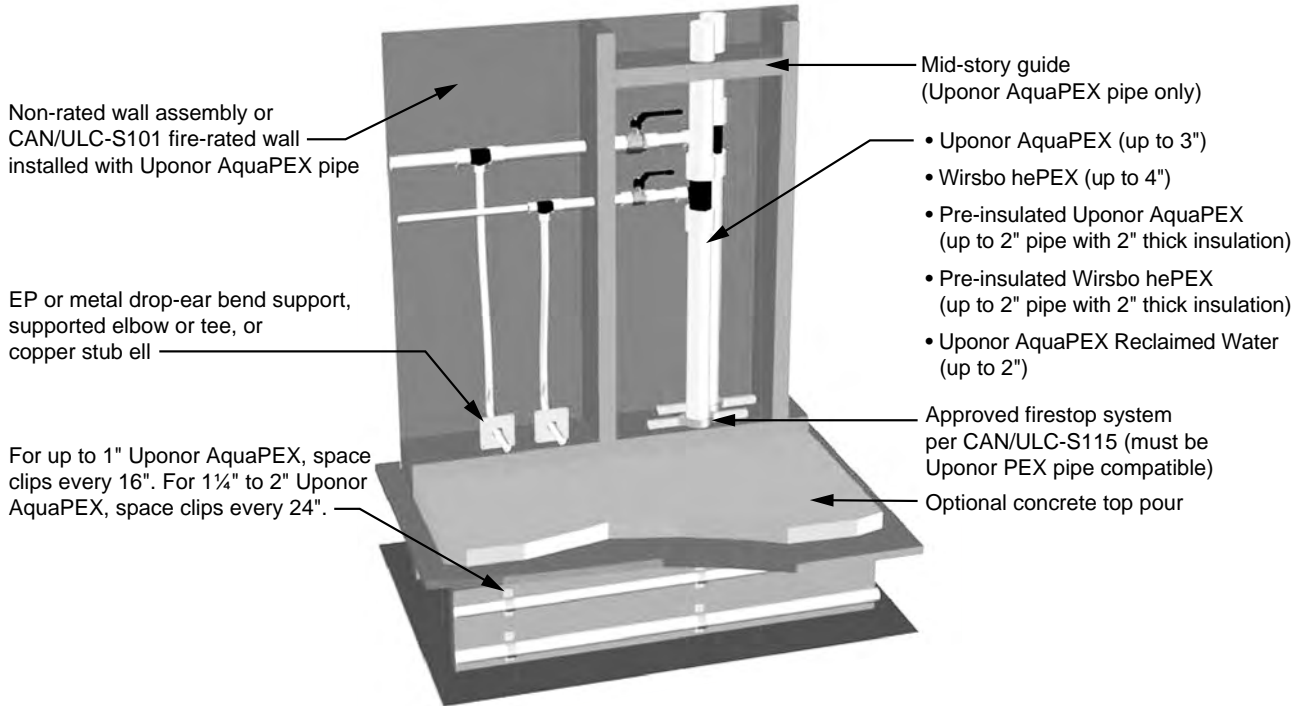

Figure 3-5: fixture detail 1



Fixture detail 2

Wood-frame floor/ceiling assembly (ITS Design No. UW/FCA 60-01/QAI Design No. P321-1F)
Wood-stud wall assembly (ITS Design No. UW/WA 60-02/QAI Design No. P321-1B)

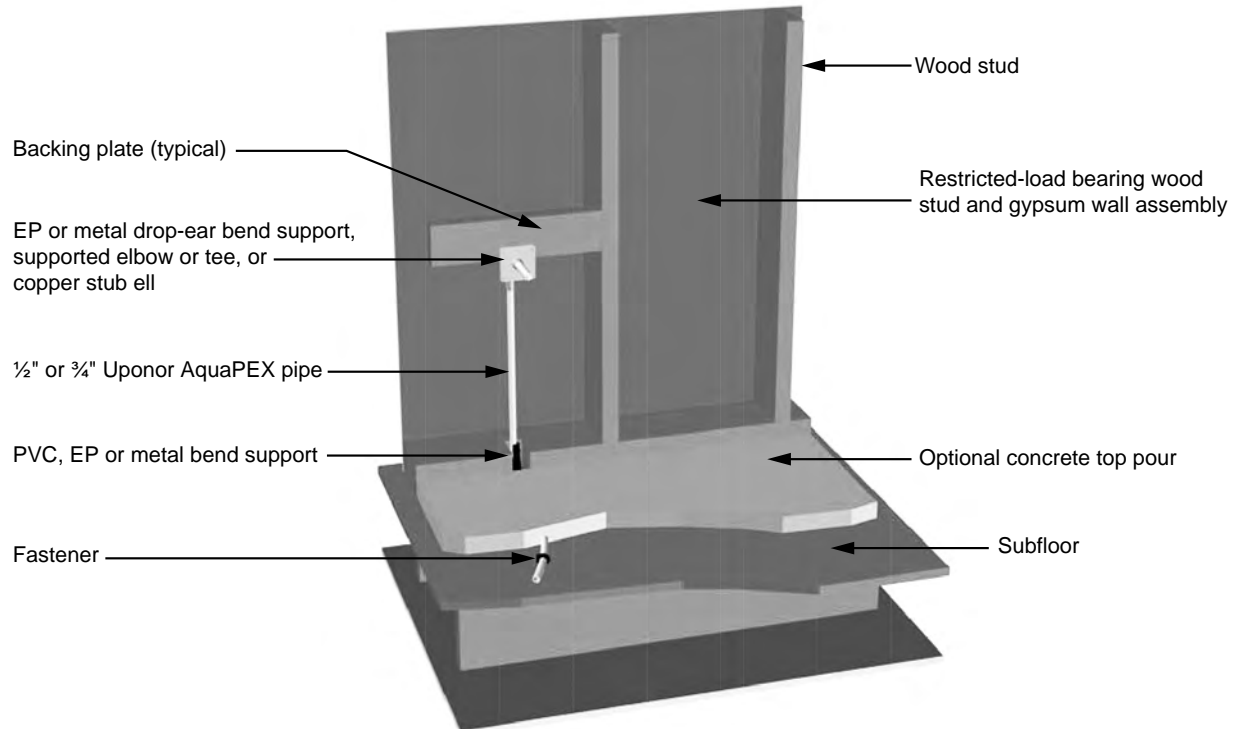

Figure 3-6: fixture detail 2



Concrete assemblies (U.S.)

Multiport tee detail

Concrete floor/ceiling assembly (UL Design No. K913/QAI Design No. P321-1D)
Steel-stud wall assembly (UL Design No. V444/QAI Design No. P321-1A)

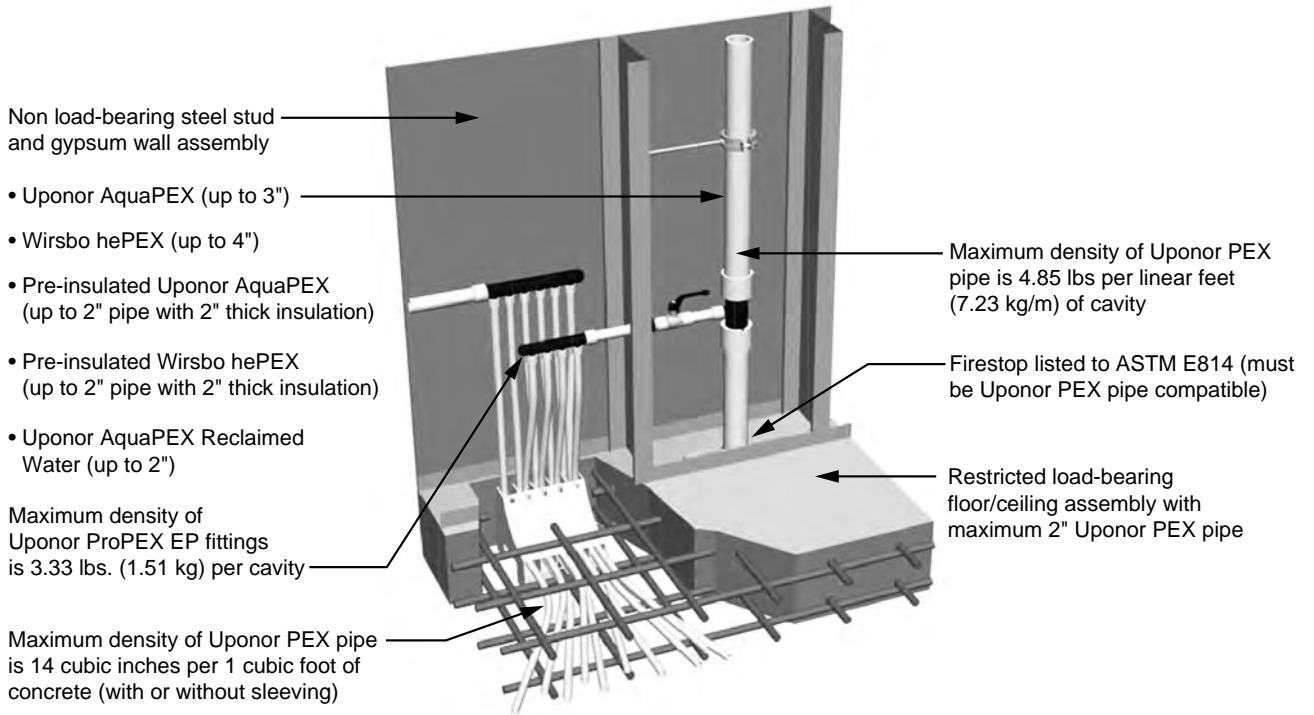

Figure 3-7: Multiport tee detail



Fixture detail

Concrete floor/ceiling assembly (UL Design No. K913/QAI Design No. P321-1D)
Steel-stud wall assembly (UL Design No. V444/QAI Design No. P321-1A)

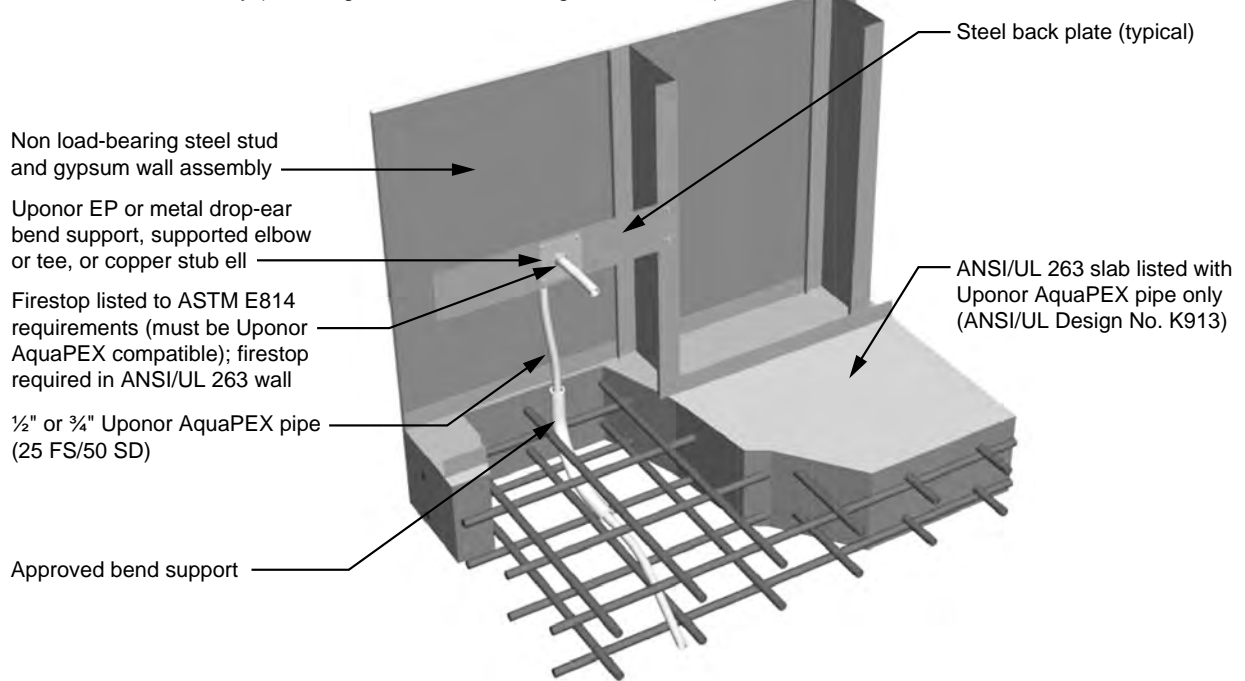

Figure 3-8: Fixture detail



Concrete assemblies (Canada)

Multiport tee detail

Concrete floor/ceiling assembly (ITS design no. UW/FCA 120-02/QAI design no. P321-1D)

Steel-stud wall assembly (ITS design no. UW/WA 60-01/QAI design no. P321-1A)

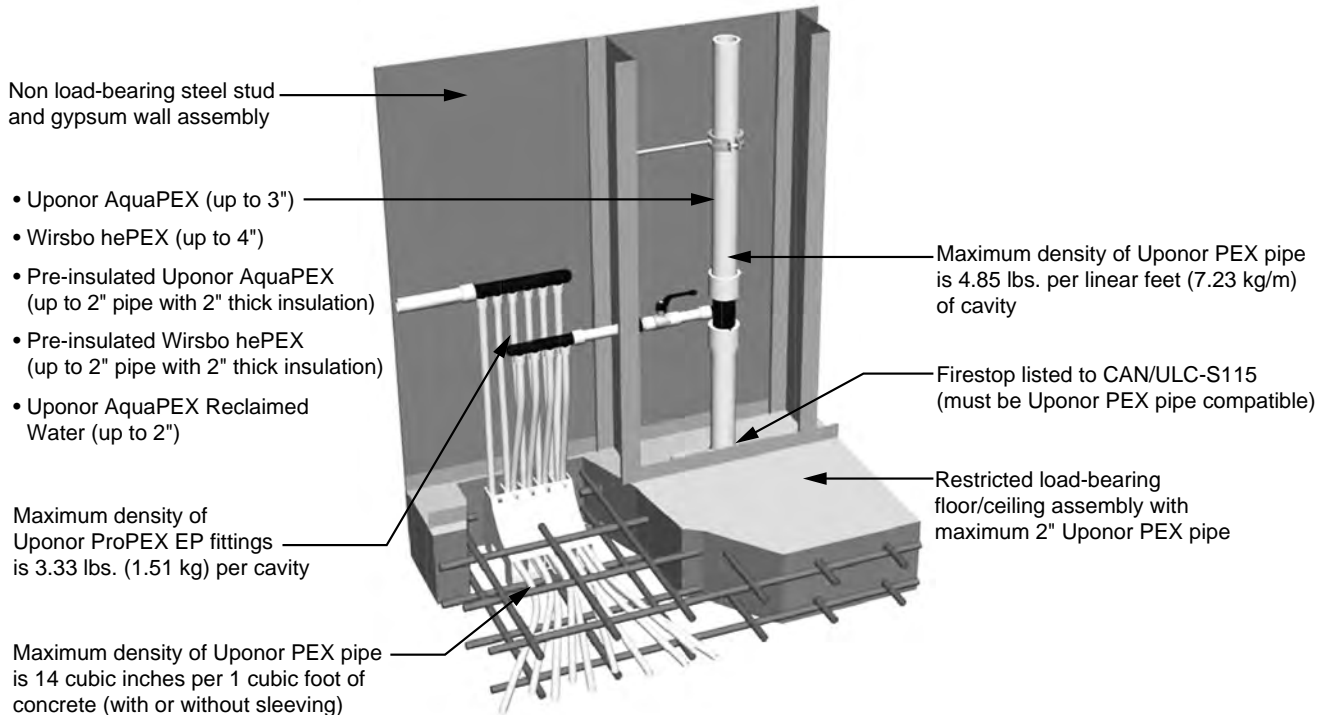

Figure 3-9: Multiport tee detail



Fixture detail

Concrete floor/ceiling assembly (ITS design no. UW/FCA 120-02/QAI design no. P321-1D)

Steel-stud wall assembly (ITS design no. UW/WA 60-01/QAI design no. P321-1A)

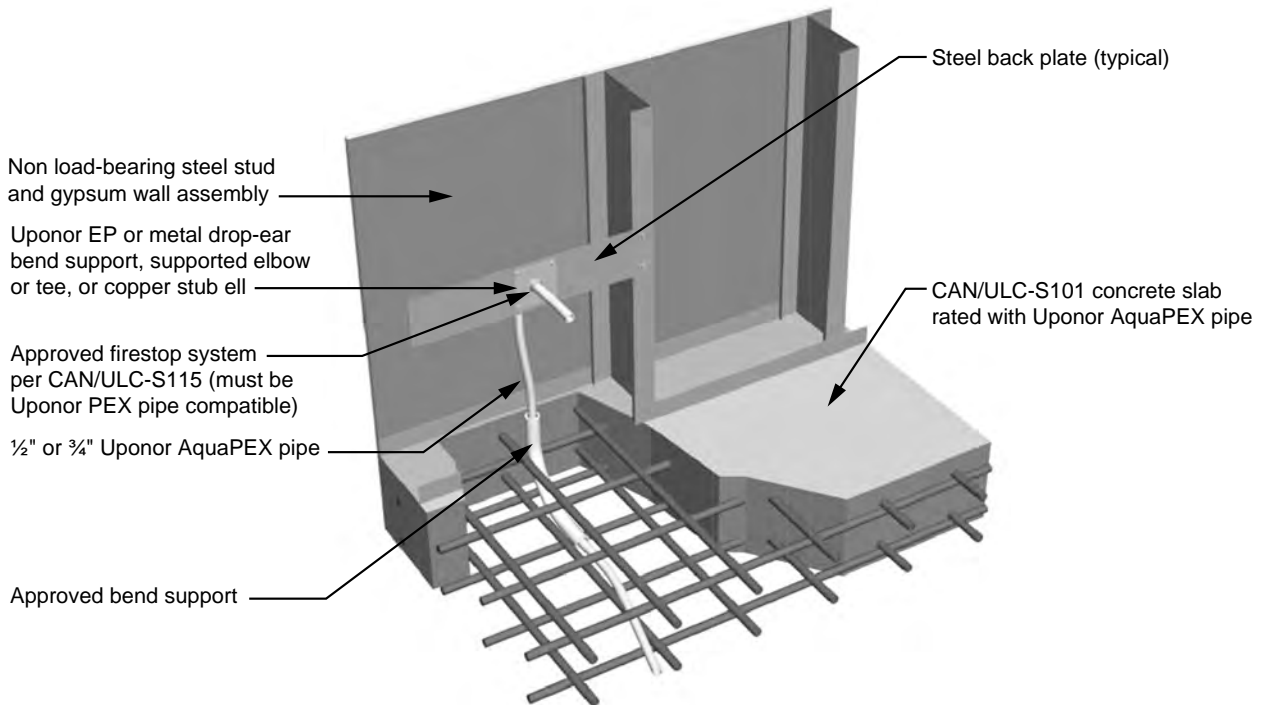

Figure 3-10: Fixture detail

ASTM E814 or CAN/ULC-S115

Combustible and non-combustible pipes penetrating a wall or floor/ceiling fire-rated assembly must include a code-compliant means of passive fire protection. The function of a passive fire protection system, such as firestopping, is to contain the fire within the area in which it started by preventing the products of combustion (smoke, hot gasses and flames) from spreading throughout the structure.

Effective firestopping requires accurate adherence to a specific combination of conditions that have been tested and listed as a system per ASTM E814, CAN/ULC-S115 or ANSI/UL 1479. Listed firestop components include the penetrated substrates, penetrating item, penetration hole, insulating materials, sealants and installation method. Deviation from the listed fire assembly documentation severely compromises the effectiveness of the firestop system.

Fire assembly documentation and listings shall be obtained from the selected firestop solution manufacturer. Most of the firestop manufacturers have system selector tools or navigators on their websites to easily research and find a listing that matches the specified type of construction.

Fire stopping solutions

There is a wide range of firestopping solutions that have been tested and listed with PEX pipe, including intumescent caulks, wrap strips, pass-through devices, collars and cast-in-place sleeves. Some firestop manufacturers include, but are not limited to, 3M™, Hilti®, RectorSeal®, Passive Fire Protection Partners, Specified Technologies Inc., Holdrite® and ProSet Systems®.

Figure 3-11: UL online certifications directory

Figure 3-12: Select appropriate features

The steps below show an example of how to research and find a listed firestop assembly for PEX pipe.

Step one

Choose a firestop solution manufacturer and consult their website or search the **UL Online Certifications Directory** for applicable listings. (See **Figure 3-11**.)

Step two

Select the desired and specified features of the through penetration system. Defining the country of use, assembly type, penetrating

item, firestopping product and F rating of the system may help refine search results. (See **Figure 3-12**.)

Step three

Review the system matches for accuracy and consider all available options. In regards to fire listings for pressure pipe applications, domestic water piping (Division 22, Section 22 11 16) and hydronic piping (Division 23, Section 23 21 13) may be defined as being “closed” or “pressure” type systems. (See **Figure 3-13** on the following page.)

WL2547

3M™ Fire Barrier Sealant CP 25WB+
1, 2 3M™ Fire Barrier Sealant IC 15WB+
3M™ Fire Barrier Water tight Sealant 3000 WT

UL

Max 2" SDR 9 PEX (closed only). U300, U400, or V400 series gypsum wallboard assemblies. Max. diameter of opening 1½" larger than OD of penetrant. Point contact to max. 1½" annular space. Concentric or eccentric installations. 1 & 2 hour F rating. No mineral wool required.

Figure 3-13: Search results

Step four

Ensure the selected fire assembly document matches:

- Type of construction
- F rating of assembly
- Through penetrant defined as crosslinked polyethylene pipe or PEX pipe

- Range of pipe size being installed
- Penetration hole size and shape
- Firestop solution availability (See Figures 3-14, 3-15 and 3-16.)

Note: It may be desirable to select a firestop product that can be used for other MEP system penetrations, such as drain, waste and vent (DWV) and conduit applications. This can help ease coordination on the jobsite during the firestop installation.

Refer to the respective firestop manufacturer for more information pertaining to the appropriate application of their products. Be mindful of information stated in the published listings to ensure compliance during installation.

Note: Ensure the required firestop material defined in the assembly (i.e., sealant) does not come into contact with Uponor EP fittings. Assemblies define the penetrating item as "PEX pipe" and therefore only PEX pipe shall come into contact with the required firestopping material.

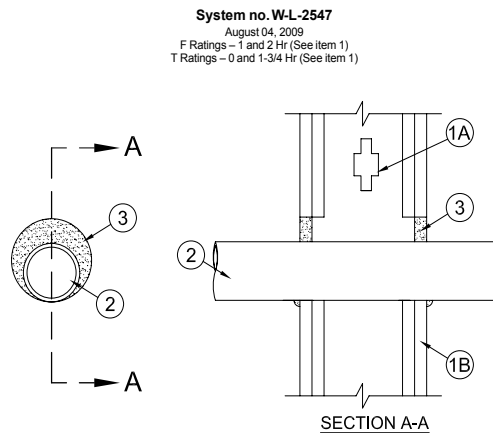
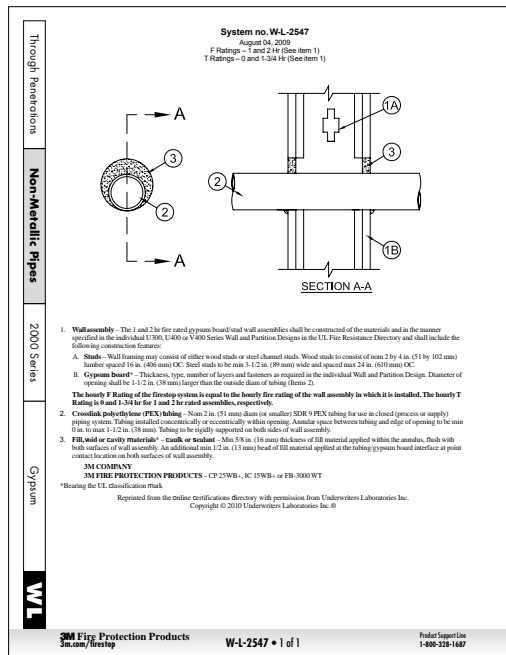

Figure 3-15: Assembly drawing

Figure 3-14: Fire assembly document

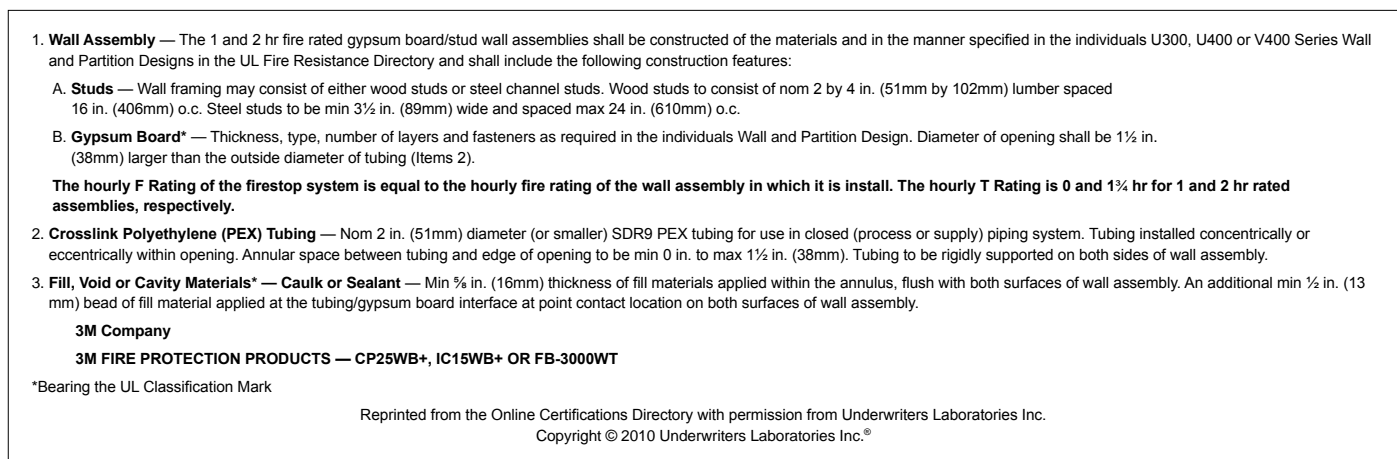

Figure 3-16: Assembly criteria

ASTM E814 and CAN/ULC-S115 listings

■ = ASTM E814 and CAN/ULC-S115 ■ = ASTM E814 only

Assembly types		Manufacturer							
		3M™		Hilti®		RectorSeal®		STI	
		Wall	Floor/clg	Wall	Floor/clg	Wall	Floor/clg	Wall	Floor/clg
Wood-stud/steel-stud assemblies	1-hour	PHV-120-04	F-C-2039	W-L-2186	F-C-2081	W-L-2342	F-C-2298	F-C-2319	F-C-2032
		PHV-120-11	F-C-2240	W-L-2235	F-C-2230	W-L-2262	F-C-8015	W-L-2100	F-C-2252
		W-L-2091	F-C-2343	W-L-2466	F-C-2310	W-L-2373	F-C-2329	W-L-2144	F-C-2319
		W-L-2146	F-C-2344	W-L-2474	F-C-2334	W-L-2430	F-C-2212	W-L-2241	F-E-2003
		W-L-2173	F-C-2391	W-L-2480	F-C-8038	W-L-2526	F-E-2007	W-L-2242	F-C-8021
		W-L-2448	F-E-2002	W-L-2537	F-C-8044	W-L-2121	F-C-2221	W-L-2423	F-C-8029
		W-L-2483	F-E-2012	W-L-2467		W-L-2209	F-C-2385	W-L-2508	F-E-8003
		W-L-2543	F-E-2040	W-L-5224		W-L-2528		W-L-2548	F-C-8045
		W-L-2547	PHV-120-04			W-L-2402		W-L-2549	F-E-8010
		W-L-2299	PHV-120-11			W-L-2638		W-L-7193	
		PV-60-02				W-L-2639		F-C-8021	
						W-L-2007		F-C-8029	
						W-L-2170		W-L-5290	
						W-L-2287		W-L-2631	
					W-L-2457				
					W-L-2524				
					W-L-2594				
					W-L-2595				
	2-hour	PHV-120-04	PHV-120-04	W-L-2186	F-C-2081	W-L-2342	F-C-2221	W-L-2100	
		PHV-120-11	PHV-120-11	W-L-2235	F-C-2310	W-L-2262	F-C-2385	W-L-2144	
		W-L-2090		W-L-2466		W-L-2373		W-L-2241	
		W-L-2091		W-L-2474		W-L-2430		W-L-2242	
		W-L-2146		W-L-2480		W-L-2526		W-L-2423	
		W-L-2448		W-L-2537		W-L-2121		W-L-2508	
		W-L-2483		W-L-2467		W-L-2209		W-L-2548	
		W-L-2543		W-L-5224		W-L-2528		W-L-2549	
W-L-2547					W-L-2402		W-L-7193		
W-L-2299					W-L-2638		W-L-5290		
					W-L-2639		W-L-2631		
					W-L-2170				

Table 3-2a: Fire assemblies per manufacturer

Note: This table is not meant to address every compatible fire assembly or firestop manufacturer. It is the end user's responsibility to ensure that the fire assembly documentation being used is approved and current for the specific application. Please refer to the respective manufacturer's website for detailed listing information.

ASTM E814 and CAN/ULC-S115 listings

■ = ASTM E814 and CAN/ULC-S115 ■ = ASTM E814 only

Assembly types	Manufacturer									
	3M™		Hilti®		RectorSeal®		STI		HOLDRITE	
	Wall	Floor/clg	Wall	Floor/clg	Wall	Floor/clg	Wall	Floor/clg	Floor/clg	
Concrete assemblies	1-hour					C-AJ-2605	C-AJ-2605			
		C-AJ-2510	C-AJ-2510	C-AJ-2170	C-AJ-2170	W-J-2162	C-AJ-2628	W-J-2021	C-AJ-2031	F-A-2188
		C-AJ-2536	C-AJ-2536	C-AJ-2407	C-AJ-2407	W-J-2122	F-A-2171	W-J-2043	C-AJ-2140	F-A-2221
		PHV-120-04	F-A-2115	C-AJ-2647	C-AJ-2647	W-J-2180	C-AJ-2701	W-J-2076	C-AJ-2291	F-B-2042
		PHV-120-11	PH-120-10	W-J-2207	C-AJ-2674	W-J-2025	C-AJ-2176	W-J-2077	F-A-2186	F-A-2269
		C-AJ-2213	PHV-120-04	W-J-2229	F-B-2040	C-AJ-2628	F-A-2235	W-J-2232	F-A-2224	F-A-2222
		C-AJ-2378	PHV-120-11	W-J-2206	F-B-2041	C-AJ-2679	F-A-2237	W-J-2233	F-A-2225	F-A-2037
		W-J-2231	C-AJ-2076	W-J-5122	F-A-2142	C-AJ-2701	C-AJ-2494	W-J-5148	C-AJ-2586	
		W-J-2110	C-AJ-2213		W-J-2071	W-J-2295	C-AJ-2679	C-AJ-2586	C-AJ-5345	
		C-AJ-2213	C-AJ-2378			W-J-2296	C-AJ-2702	C-AJ-5345	C-BJ-2046	
		C-AJ-2378	C-AJ-2213			C-AJ-2702		C-BJ-2046		
		C-AJ-2738	C-AJ-2378			C-AJ-2176		W-J-2291		
		PHV-120-12	C-AJ-2738			C-AJ-2494				
		C-AJ-2698	PHV-120-12			W-J-2035				
		C-AJ-2698			W-J-2051					
					W-J-2142					
					W-J-2197					
					W-J-2220					
					W-J-2222					
					W-J-2224					
					W-J-2266					
	3-hour			C-BJ-2028	C-BJ-2028	C-AJ-2119	C-AJ-2119	C-AJ-2671	C-AJ-2671	F-A-2176
				C-BJ-2040	C-BJ-2040	C-AJ-2194	C-AJ-2194	C-AJ-5344	C-AJ-5344	F-A-2221
				C-BJ-2041	C-BJ-2041	C-AJ-2622	C-AJ-2622	C-AJ-5346	C-AJ-5346	F-B-2042
									C-AJ-2578	F-A-2269
									F-A-2203	F-A-8034
									F-A-2204	F-A-2222

Table 3-2b: Fire assemblies per manufacturer

Note: This table is not meant to address every compatible fire assembly or firestop manufacturer. It is the end user's responsibility to ensure that the fire assembly documentation being used is approved and current for the specific application. Please refer to the respective manufacturer's website for detailed listing information.

Cast-in-place sleeves

Several manufacturers offer cast-in-place sleeves, which provide floor/ceiling penetrations in concrete slab applications. Some manufactures include:

- Holdrite
- ProSet Systems
- Hilti
- HydroFlame

Refer to the respective manufacturer's website for detailed product information.

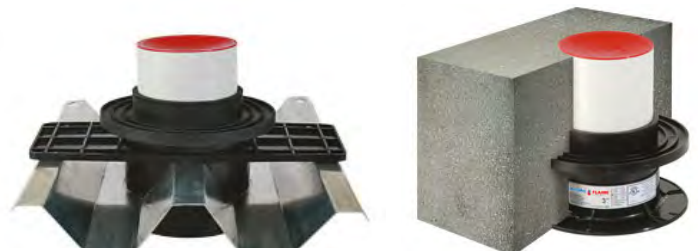

Figure 3-17: Cast-in-place sleeves



ASTM E84 — surface burning characteristics

As defined by the International Building Code (IBC), combustible piping may be installed in areas required to be of noncombustible construction, provided the piping is installed in a wall or concrete-floor slab or the pipe has a flame-spread (FS) index rating of not more than 25 and a smoke-developed (SD) index rating of not more than 50 when tested in accordance with ASTM E84.

Uponor PEX-a piping systems comprised of Uponor PEX-a piping, Uponor ProPEX rings, Uponor EP fittings, Uponor LF brass fittings and Uponor PEX-a Pipe Support products are listed for installation in return-air plenums as tested in accordance with ASTM E84.

The below listings apply to Uponor PEX-a piping systems installed in either horizontal or vertical orientations in the field. Refer to **Table 3-3** for installation requirements.

QAI P321-1 1/2" to 3/4" Uponor PEX-a (uninsulated)

Adjacent runs of uninsulated 1/2" to 3/4" Uponor PEX-a piping in a return-air plenum must be separated by 18".

QAI P321-2 Up to and Including 3" Uponor PEX-a Supported with Uponor PEX-a Pipe Support

See **Chapter 6** for installation details. Uponor PEX-a piping manufactured with a maximum nominal outside diameter (OD) of 3" and supported with Uponor PEX-a Pipe Support.

Pipe or fitting sections without PEX-a Pipe Support must be covered with a rated insulation per **Table 3-5**. There is no minimum length of PEX-a Pipe Support segments. There are also no spacing limitations between adjacent runs of this pipe.

QAI P321-1 Up to and Including 3" Uponor PEX-a (insulated)

Uponor PEX-a piping manufactured with a maximum nominal OD of 3" and encased in a minimum 1/2" thick insulation in accordance with **Table 3-5** shall have no limitation on spacing.

Classified as to surface burning characteristics

ASTM E84	Flame spread	Smoke developed	Limitations
Nominal 1/2" to 3/4" size	25 or less	50 or less	Adjacent pipe runs shall be located at least 18" apart.
3" maximum nominal size Uponor PEX-a Supported with Uponor PEX-a Pipe Support	25 or less	50 or less	Pipe or fitting sections without PEX-a Pipe Support must be covered with a rated insulation per Table 3-5 . There is no minimum length of PEX-a Pipe Support segments.
3" maximum nominal size Uponor PEX-a with 1/2" insulation	25 or less	50 or less	1/2" minimum thickness insulation as specified in Table 3-5 .

Table 3-3: Uponor AquaPEX ASTM E84 requirements

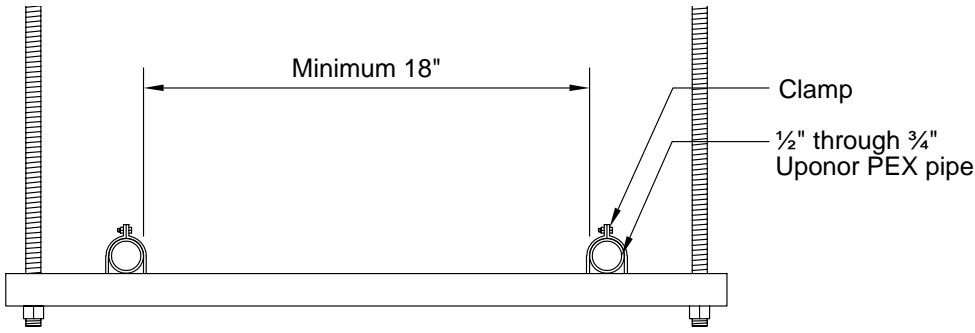

Figure 3-18: QAI P321-1

Guidelines: ½" through ¾" (uninsulated)

Limitations: Adjacent runs shall be located at least 18" apart.

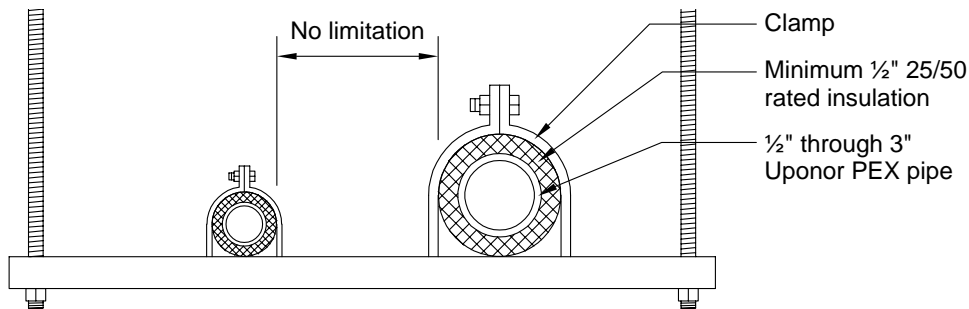

Figure 3-19: QAI P321-1

Guidelines: ½" through 3" (insulated)

Limitations: ½" minimum thickness insulation as specified in **Table 3-3**.

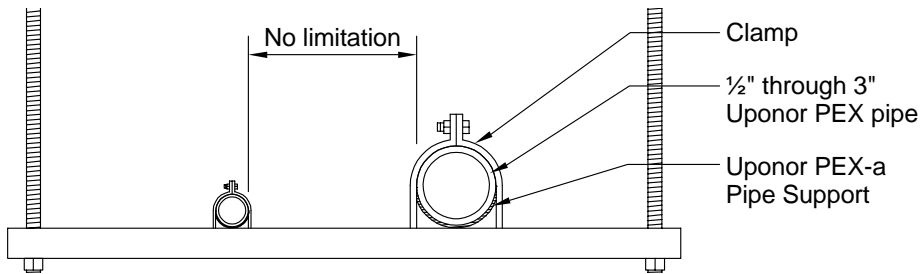

Figure 3-20: QAI P321-2

Guidelines: ½" through 3" (PEX-a pipe support)

Pipe or fitting sections without PEX-a pipe support must be covered with a rated insulation per **Table 3-5**.

There is no minimum length of PEX-a pipe support segments.



**CAN/
ULC-S102.2 —
surface burning
characteristics**

As defined by the National Building Code of Canada (NBCC), combustible piping may be installed in areas required to be of noncombustible construction, provided the piping is installed in a wall or concrete-floor slab or the pipe has a flame-spread (FS) index rating of not more than 25 and a smoke-developed (SD) index rating of not more than 50 when tested in accordance with CAN/ULC-S102.2.

Uponor PEX-a piping systems comprised of Uponor PEX-a piping, Uponor ProPEX rings, Uponor EP fittings, Uponor LF brass fittings and Uponor PEX-a pipe support products are listed for installation in return-air plenums as tested in accordance with CAN/ULC-S102.2.

The below listings apply to Uponor PEX-a piping systems installed in either horizontal or vertical orientations in the field. Refer to **Table 3-4** for installation requirements.

QAI P321-1

½" Uponor PEX-a (Uninsulated)

Adjacent runs of un-insulated ½" Uponor PEX-a piping in a return-air plenum have no spacing limitations.

¾" and 1" Uponor PEX-a (Uninsulated)

Adjacent runs of uninsulated ¾" and 1" Uponor PEX-a piping must be separated by 18".

QAI P321-1

Up to and including 3" Uponor PEX (insulated)

Uponor PEX piping manufactured with a maximum nominal OD of 3" and encased in ½" insulation in accordance with **Table 3-5** shall have no limitation on spacing.

QAI P321-3

Up to and Including 2" Uponor PEX-a (Water-filled, Uninsulated)

Adjacent runs of water-filled, uninsulated piping in a return-air plenum have a no spacing limitations.

Classified as to surface burning characteristics

CAN/ULC S102.2	Flame spread	Smoke developed	Limitations
½" nominal size	25 or less	50 or less	No spacing limitations.
¾" and 1" nominal sizes	25 or less	50 or less	Adjacent pipe runs shall be located at least 18" apart.
2" maximum nominal size (water-filled)	25 or less	50 or less	No spacing limitations.
3" maximum nominal size Uponor PEX-a with ½" insulation	25 or less	50 or less	½" minimum thickness insulation as specified in Table 3-5 .

Table 3-4: Uponor AquaPEX CAN/ULC-S102.2 requirements

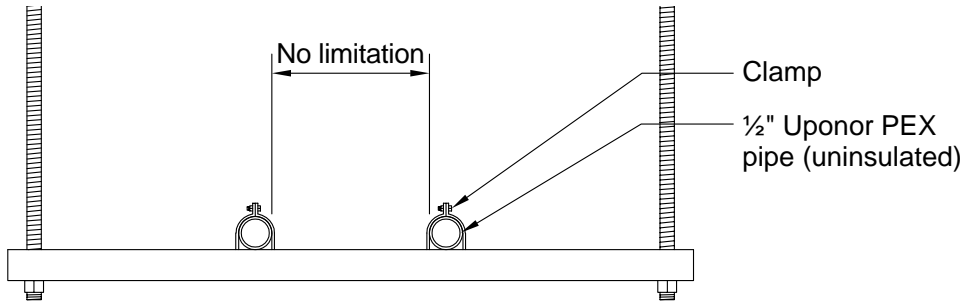

Figure 3-21: QAI P321-1

Guidelines: 1/2" (uninsulated)

Limitations: No spacing limitations.

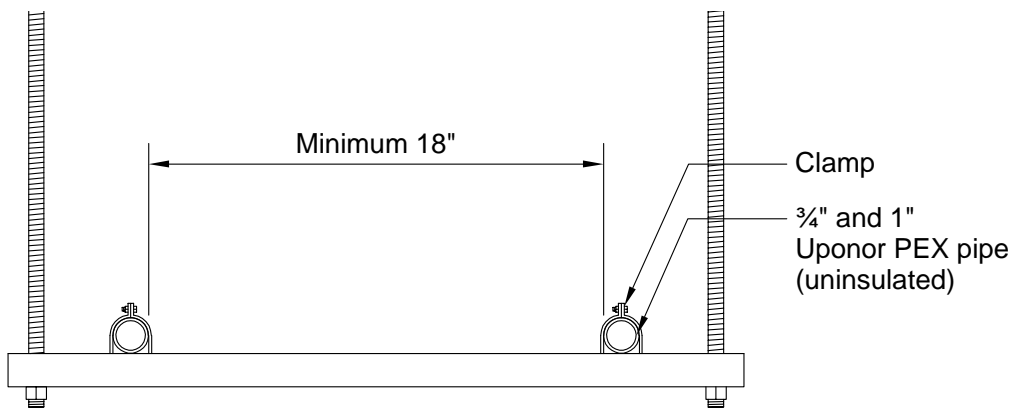

Figure 3-22: QAI P321-1

Guidelines: 3/4" and 1" (uninsulated)

Limitations: Adjacent pipe runs shall be located at least 18" apart.

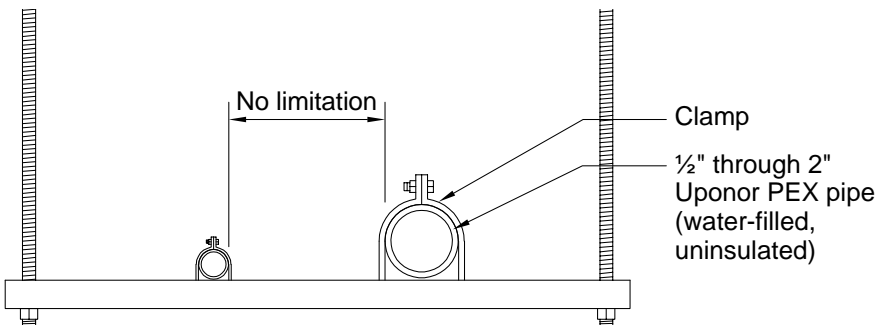

Figure 3-23: QAI P321-3

Guidelines: 1/2" through 2" (water-filled)

Limitations: No spacing limitations

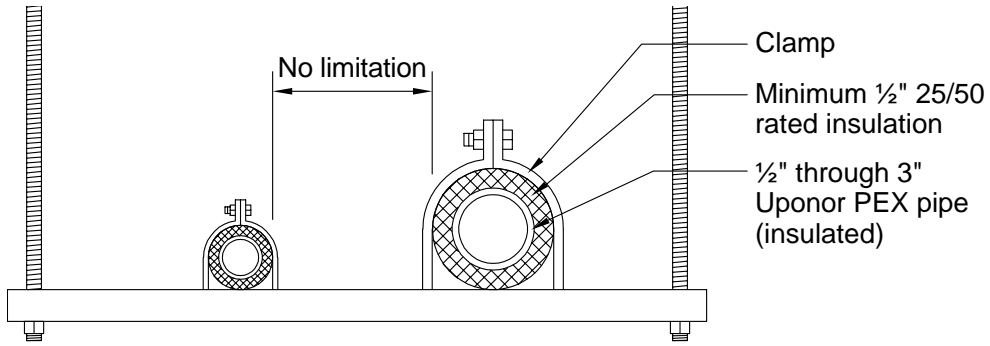

Figure 3-24: QAI P321-1

Guidelines: 1/2" through 3" (insulated)

Limitations: 1/2" minimum thickness insulation as specified in **Table 3-5**

Underwriters Laboratories (UL) 2846

Until recently, piping materials were to be tested under the ASTM E84 method, which was originally developed to test building construction components. The UL 2846 test method was developed specifically for plastic piping materials to test flame and smoke development.

Uponor PEX piping (up to 4") carries the UL 2846 *Standard for Fire Test of Plastic Water Distribution Plumbing Pipe for Visible Flame and Smoke Characteristics*.

Approved Uponor PEX pipes include:

- Uponor AquaPEX (up to 3")
- Wirsbo hePEX (up to 4")

Installation criteria

Piping must be covered with a minimum ½" thick, UL-classified pipe and equipment covering material as described on the marking.

Specifications for pipe insulations in ASTM E84 and CAN/ULC-S102.2 applications

Products (minimum thickness)	ASTM E84 and CAN/ULC-S102.2		Density of insulation
	Flame spread	Smoke developed	
½" Manson Alley-K Fiberglass Pipe Insulation	25 or less	50 or less	4.0 pcf
½" Armaflex Composite Pipe Insulation	25 or less	50 or less	3.0 pcf
½" Johns Manville Micro-Lok Fiberglass Pipe Insulation	25 or less	50 or less	3.3 pcf
½" Johns Manville Micro-Lok HP	25 or less	50 or less	3.5 pcf
½" Owens Corning VaporWick Pipe Insulation	25 or less	50 or less	4.0 pcf
½" Owens Corning Fiberglass Pipe Insulation	25 or less	50 or less	3.5 pcf
½" Knauf Earthwool Redi-Klad Pipe Insulation	25 or less	50 or less	3.8 pcf
½" GLT Pipe and Tank Insulation	25 or less	50 or less	4.5 pcf
½" Nomalock Pipe Insulation*	25 or less	50 or less	4.0 pcf

Table 3-5: Specifications for pipe insulations in ASTM E84 and CAN/ULC-S102.2 applications

*Check the rated grade of Nomalock insulations for plenum use.

Chapter 4: Pipe sizing

Standard dimension ratio

Standard dimension ratio (SDR) is a term used in describing the size of PEX piping — it is the conceptual equivalent of a pipe schedule. Dimension ratio (DR) is the average outside diameter (OD) of PEX piping divided by its minimum wall thickness.

Temperature and pressure ratings

Temperature and pressure ratings for PEX piping are determined by the Plastics Pipe Institute (PPI) as required by the ASTM F876 standard. The minimum burst pressure per F876 is 480 psi at 73°F (22.7°C) for ½" PEX and 475 psi at 73°F (22.7°C) for ¾" and larger PEX.

Note that Uponor PEX pipe can withstand burst pressures up to 800 psi at 73°F (22.7°C) without failure, so designers can feel comfortable designing Uponor PEX pipe up to its maximum temperature and pressure limits.

To start the evaluation, pipes of all sizes are empirically tested to ASTM D2837 to determine the hydrostatic design basis (HDB); this test method is used for all polyethylene-based piping. That data is then multiplied by 0.5 design factor to determine the hydrostatic design stress (HDS). The HDS is then run through an ISO equation (ISO R-161-1690) to determine the temperature and pressure limits of the pipe.

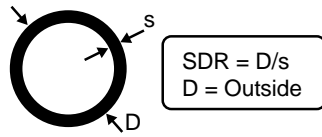

ISO Equation 2S/P = R-1
Where S = HDS, P = psi, R = SDR

Pipe sizing an Uponor AquaPEX plumbing system

Uponor AquaPEX pipe is manufactured to have an outside diameter (OD) equal to copper tube size (CTS) dimensions and a wall thickness with a standard dimension ratio (SDR) of 9 (i.e., wall thickness is one-ninth the pipe OD).

Due to the thickness of PEX, which provides superior insulation and durability characteristics, the inside diameter (ID) of Uponor

ASTM F876 temperature and pressure ratings for SDR9 PEX		
Rated temperature (°F)	Hydrostatic design stress (psi)	Pressure rating for water (psi)
73.4	630	160
180	400	100
200	315	80

Table 4-1: ASTM F876 temperature and pressure ratings for SDR9 PEX

AquaPEX pipe is slightly smaller than that of copper pipe. However, Uponor PEX is three times smoother than new copper pipe. This smoothness means it can be designed at higher velocities, thus reducing the difference in flow characteristics between PEX-a and copper (resulting from PEX-a's smaller ID).

To calculate pressure loss for an Uponor AquaPEX plumbing system, refer to the **Uponor PEX friction loss tables** in **Appendix B** or online at uponorpro.com in Technical Support/Manuals/Plumbing.



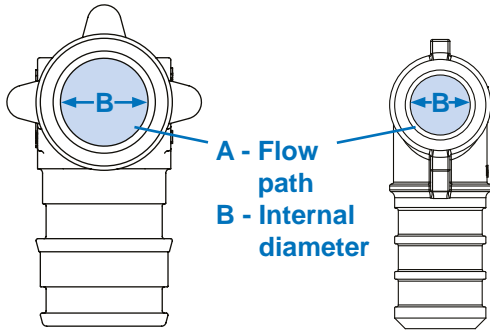

A - Flow path
B - Internal diameter

29% LARGER I.D.
70% GREATER flow¹

¹When comparing 1" F1960 EP with F2159 plastic fittings.

**ProPEX ASTM F1960
and CAN/CSA B137.5
expansion fitting**

**ASTM F1807/F2159
insert fitting**

		Uponor ProPEX cold-expansion fitting		Standard insert (crimp) fitting	
		ASTM F1960 brass	ASTM F1960 EP	ASTM F1807 brass	ASTM F2159 plastic
A Flow path	½"	0.112 sq. inches 2.8 gpm @ 8 ft./sec. 4.2 gpm @ 12 ft./sec.	0.116 sq. inches 2.9 gpm @ 8 ft./sec. 4.4 gpm @ 12 ft./sec.	0.096 sq. inches 2.4 gpm @ 8 ft./sec. 3.6 gpm @ 12 ft./sec.	0.078 sq. inches 1.9 gpm @ 8 ft./sec. 2.9 gpm @ 12 ft./sec.
	¾"	0.278 sq. inches 6.9 gpm @ 8 ft./sec. 10.4 gpm @ 12 ft./sec.	0.273 sq. inches 6.8 gpm @ 8 ft./sec. 10.2 gpm @ 12 ft./sec.	0.221 sq. inches 5.5 gpm @ 8 ft./sec. 8.3 gpm @ 12 ft./sec.	0.166 sq. inches 4.1 gpm @ 8 ft./sec. 6.2 gpm @ 12 ft./sec.
	1"	0.496 sq. inches 12.4 gpm @ 8 ft./sec. 18.6 gpm @ 12 ft./sec.	0.488 sq. inches 12.2 gpm @ 8 ft./sec. 18.2 gpm @ 12 ft./sec.	0.396 sq. inches 9.9 gpm @ 8 ft./sec. 14.8 gpm @ 12 ft./sec.	0.292 sq. inches 7.3 gpm @ 8 ft./sec. 10.9 gpm @ 12 ft./sec.
	1¼"	0.724 sq. inches 21.8 gpm @ 8 ft./sec. 32.6 gpm @ 12 ft./sec.	0.739 sq. inches 18.4 gpm @ 8 ft./sec. 27.6 gpm @ 12 ft./sec.	0.595 sq. inches 14.8 gpm @ 8 ft./sec. 22.2 gpm @ 12 ft./sec.	Not available
	1½"	0.923 sq. inches 23.0 gpm @ 8 ft./sec. 34.5 gpm @ 12 ft./sec.	0.923 sq. inches 23.0 gpm @ 8 ft./sec. 34.5 gpm @ 12 ft./sec.	0.817 sq. inches 20.4 gpm @ 8 ft./sec. 30.6 gpm @ 12 ft./sec.	Not available
	2"	1.877 sq. inches 47.1 gpm @ 8 ft./sec. 70.6 gpm @ 12 ft./sec.	1.730 sq. inches 43.1 gpm @ 8 ft./sec. 64.7 gpm @ 12 ft./sec.	1.463 sq. inches 36.5 gpm @ 8 ft./sec. 54.7 gpm @ 12 ft./sec.	Not available
	2½"	3.110 sq. inches 77.6 gpm @ 8 ft./sec. 116.3 gpm @ 12 ft./sec.	2.688 sq. inches 67.0 gpm @ 8 ft./sec. 100.6 gpm @ 12 ft./sec.	Not available	Not available
	3"	4.562 sq. inches 113.8 gpm @ 8 ft./sec. 170.6 gpm @ 12 ft./sec.	3.871 sq. inches 96.5 gpm @ 8 ft./sec. 144.8 gpm @ 12 ft./sec.	Not available	Not available
B Minimum internal diameter	½"	0.378"	0.385"	0.350"	0.315"
	¾"	0.595"	0.590"	0.530"	0.460"
	1"	0.795"	0.788"	0.710"	0.610"
	1¼"	0.960"	0.970"	0.870"	Not available
	1½"	1.084"	1.084"	1.020"	Not available
	2"	1.550"	1.484"	1.365"	Not available
	2½"	1.990"	1.850"	Not available	Not available
	3"	2.410"	2.220"	Not available	Not available

Table 4-2: Uponor ProPEX fittings vs. standard insert (crimp) fittings

Note: Refer to **Table C-1** in **Appendix C** for an equivalent length comparison.



U.S. pipe sizing

For sizing an Uponor AquaPEX plumbing system in residential and light commercial buildings in the U.S., use the fixture unit tables for determining pipe size as published in the model plumbing codes.

To support this pipe sizing practice, Uponor consulted with the International Code Council (ICC) and the International Association of Plumbing and Mechanical Officials (IAPMO) by means of an evaluation report (ER) to substantiate their approvals.

The following ER numbers endorse the use of the 2012 UPC Table 610.4 (see **page 44**) (or 2009-prior UPC Table 6-6) and 2015-prior IPC Table E201.1 (see **pages 45-46**) for pipe sizing an Uponor AquaPEX plumbing system.

- IAPMO ER-0253
- ICC ES PMG 1006



Canada pipe sizing

For sizing an Uponor AquaPEX plumbing system in residential high-rise and small commercial buildings in Canada, use **Table A-2.6.3.1.(2)A** (see **page 47**) and other applicable sections within the 2015 National Plumbing Code of Canada (NPCC).

Uniform friction loss method

For larger systems, the most common method of pipe sizing is the uniform friction loss method. This method utilizes the pipe material's specific flow characteristics in conjunction with velocity sizing criteria (see **Appendix B** for Uponor PEX friction loss tables).

The following examples illustrate how to employ the uniform friction loss method.

To simplify the uniform friction loss method when sizing an Uponor AquaPEX plumbing system, use Uponor's pipe sizing calculator at uponorpro.com/calculator.

Step one

Perform a building water supply calculation to determine how much pressure is available for friction loss through the pipe and fittings. (See **Figure 4-1**.)

Designer must know the following:

- Pressure available at building (minimum static pressure available before water meter or after hydro-pneumatic tank/booster-pump system)
- Minimum fixture working pressure (minimum pressure required at farthest fixture outlet)

Note: Be sure to select the most demanding fixture in the farthest fixture group (i.e., bathtub). Refer to local code for minimum fixture working pressure.

- Static loss (height in feet of the highest fixture outlet above the supply source)
- Additional component loss (total pressure loss in psi of the following system components — water meter, filters, softeners, backflow prevention devices and pressure regulators)

Step two

Calculate the total developed length (TDL) of the system and divide the available pressure for friction loss (calculated in **Figure 4-1**) by the TDL to determine the friction loss per foot or per 100 feet of pipe. (See **Figure 4-2**.)

Designer must know the following:

- Longest run to fixture (total linear feet of piping from water meter or supply source to the most hydraulically demanding fixture)
- Fitting allowance (percentage of longest run piping that represents friction loss through fittings and valves along the critical path, typically between 20 and 50 percent for an Uponor AquaPEX system)

Note: Alternatively, the designer can add up equivalent-length losses of fittings and valves along the critical path and add to the longest run footage.

Enter your domestic water supply parameters:		Calculation:
<input type="text" value="60"/>	Pressure available at building	+ 60.00 PSI
<input type="text" value="15"/>	Minimum fixture working pressure	- 15.00 PSI
<input type="text" value="20"/>	Static loss — system height (ft.)	20.00 x 0.433 - 8.66 PSI
<input type="text" value="5"/>	Additional component loss	- 5.00 PSI
		Available pressure for friction loss = 31.34 PSI

Figure 4-1: Building water supply calculation

Step three

Develop water size charts for each pipe material and water temperature. (See **Figures 4-3** and **4-4**.)

Designer must know the following:

- Pipe materials being designed and range of sizes for each system
- Supply and return design water temperatures

Note: For commercial systems, size domestic hot-water return piping per the requirements stated in ASPE Plumbing Engineering Design Handbook, Volume 2, *Plumbing Systems*

- Maximum velocity of each pipe material per water temperature

- Table approved by the local authority having jurisdiction (AHJ) or referenced plumbing code table for converting gallons per minute (gpm) to water supply fixture units (WSFU)
- If the domestic cold-water system demand is predominately flush valve or flush tank WSFU

Step four

Apply the appropriate water size chart to the plumbing design. Calculate WSFU demand per pipe segment by adding all the WSFUs of the fixtures being supplied by that pipe segment. (See **Figure 4-5**.)

Enter your piping supply information:		Calculation:
<input type="text" value="250"/>	Longest run to fixture (ft.)	+ 250.00 FT
<input type="text" value="25"/>	Fitting allowance (% of number above)	+ 62.50 FT
		Total developed length = 312.50 FT
		Friction loss rate per foot (Friction loss/TDL) = 0.100 PSI/FT
		Friction loss rate per 100 feet (Friction loss/TDL * 100) = 10.028 PSI/100 FT

Figure 4-2: Determine the friction loss per foot (or per 100 feet) of pipe

Enter your system parameters for each table:			
A	B	C	
<input type="text" value="60"/>	<input type="text" value="120"/>	<input type="text" value="110"/>	Water size table temperature (°F)
<input type="text" value="10"/>	<input type="text" value="8"/>	<input type="text" value="2"/>	Maximum velocity per water temperature (ft./sec.)
<input type="text" value="FT"/> ▼	<input type="text" value="FT"/> ▼	<input type="text" value="FT"/> ▼	WSFU predominant fixture curve
<input type="text" value="2012 UPC"/> ▼			Applicable plumbing code

Figure 4-3: System parameters

Uponor AquaPEX design parameters

Domestic cold-water piping

- Maximum velocity of 12 ft./sec. through pipe
- Recommended velocity of 10 ft./sec. through pipe

Domestic hot-water piping

- Maximum velocity of 8 ft./sec. through pipe
- Maximum operating temperature of 200°F (93.3°C)

Domestic hot-water return piping

- Maximum velocity of 2 ft./sec. through pipe
- Maximum operating temperature of 140°F (60°C)

- Sized per the requirements stated in ASPE Plumbing Engineering Design Handbook, Volume 2, *Plumbing Systems*

Note: Uponor allows the dedicated fixture supply pipe to be of the same nominal size as the fixture being supplied, provided the dedicated pipe is no longer than 25 linear feet from a uniform-friction-loss-sized pipe.

Note: Uponor allows the use of ½" pipe for domestic hot-water return piping provided a flow-control device is in place to maintain velocities at or below 2 ft./sec. Refer to **Table 5-8** on **page 55** for appropriate flow rates at 2 ft./sec.

To determine the maximum velocities based on the use, geographical region and intended operating conditions for your specific project, contact Uponor Design Services at: U.S.: 888.594.7726 or design.services@uponor.com
Canada: 888.994.7726 or design.ca@uponor.com

Water size chart for Uponor AquaPEX

Uponor AquaPEX water size table 2012 UPC — flush tank 100% water at 60°F 10.028 PSI/100 ft. Maximum velocity = 10 ft./sec.				Uponor AquaPEX water size table 2012 UPC — flush tank 100% water at 120°F 10.028 PSI/100 ft. Maximum velocity = 8 ft./sec.				Uponor AquaPEX water size table 2012 UPC — flush tank 100% water at 110°F 10.028 PSI/100 ft. Maximum velocity = 2 ft./sec.			
Pipe size	WSFU range	Velocity (ft./sec.)	GPM	Pipe size	WSFU range	Velocity (ft./sec.)	GPM	Pipe size	WSFU range	Velocity (ft./sec.)	GPM
¾"	0-0	3.60	1.08	¾"	0-0	4.10	1.23	¾"	0-0	2.0	0.60
½"	1-2	4.60	2.54	½"	1-2	5.00	2.76	½"	0-0	2.0	1.10
¾"	3-7	5.80	6.39	¾"	3-8	6.40	7.05	¾"	1-1	2.0	2.20
1"	8-17	7.00	12.73	1"	9-19	7.60	13.83	1"	2-3	2.0	3.64
1¼"	18-33	8.00	21.76	1¼"	20-33	8.00	21.76	1¼"	4-6	2.0	5.44
1½"	34-63	9.00	34.10	1½"	34-54	8.00	30.31	1½"	7-9	2.0	7.58
2"	64-199	10.00	64.97	2"	55-134	8.00	51.97	2"	10-17	2.0	12.99
2½"	200-375	10.00	99.01	2½"	135-270	8.00	79.21	2½"	18-29	2.0	19.80
3"	376-589	10.00	140.79	3"	271-443	8.00	112.63	3"	30-49	2.0	28.16

Figure 4-4: Water size chart

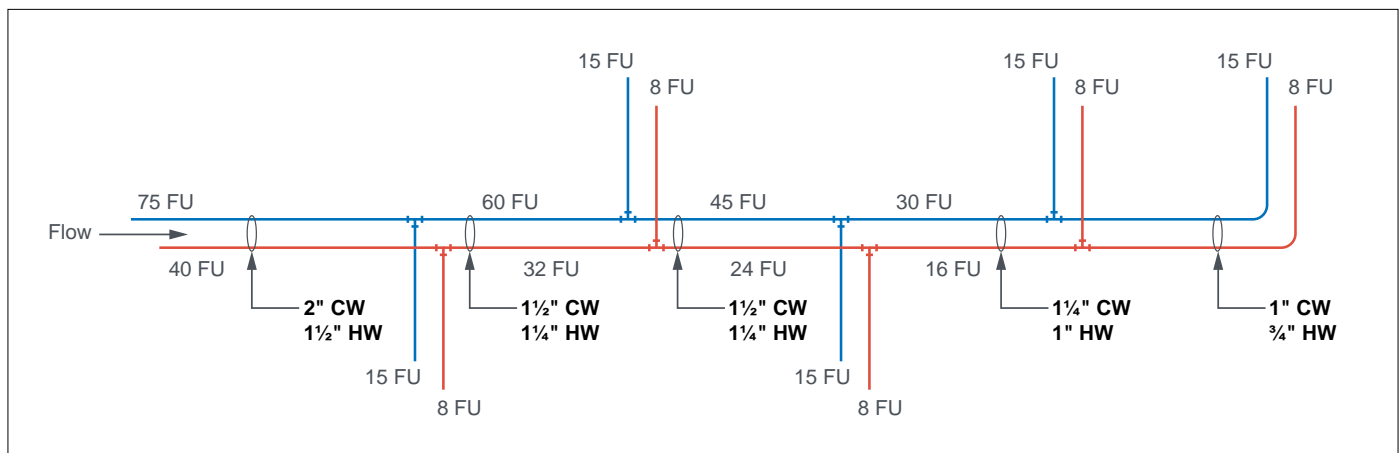

Figure 4-5: Apply water size chart to plumbing design

Friction loss with Uponor PEX piping

There are two commonly accepted methods to calculate head loss or friction loss in piping systems. The first method, which is preferred and will be discussed in this manual, is the Darcy-Weisbach methodology. The second method is the Hazen-Williams methodology.

Darcy-Weisbach method

The Darcy-Weisbach equation is a phenomenological equation, which is directly related to empirical test data.

This method relates friction in piping to the roughness of the pipe, fluid velocity, fluid density (water temperature) and fluid viscosity without leveraging correction factors. This is the same for systems using different concentrations of fluids (e.g., propylene glycol).

The following shows a Darcy-Weisbach equation

$$h_f = f \cdot \frac{l}{D} \cdot \frac{V^2}{2g}$$

Where,

h_f = head loss due to friction (ft)

f = dimensionless friction factor

l = length of pipe (ft)

D = internal pipe diameter (ft)

V = average velocity (ft/sec)

g = acceleration due to gravity $\left(\frac{ft}{sec^2}\right)$

All the parameters in the equation are functions of system design and layout except for the dimensionless friction factor, f . The friction factor f is derived using the Colebrook formula which represents f implicitly.

$$\frac{1}{\sqrt{f}} = -2 \cdot \log \left[\frac{\epsilon/D}{3.7} + \frac{2.51}{Re \sqrt{f}} \right]$$

Where,

f = dimensionless friction factor

D = internal pipe diameter (ft)

E = internal roughness (ft)

The roughness of Uponor PEX-a pipe is 1.58×10^{-6} ft.

Re = Reynolds number = $\frac{\rho V D}{\mu}$

Where,

D = internal pipe diameter (ft)

ρ = fluid density $\left(\frac{lb}{ft^3}\right)$

V = average velocity (ft/sec)

μ = dynamic viscosity $\left(\frac{lb \cdot sec}{ft^2}\right)$

Since the Colebrook formula is an implicit formula, many approximations have been derived to explicitly represent the friction factor. Using the Manadilli approximation yields a very small error with respect to the Colebrook equation. In fact, the maximum error is up to 2.06 percent. The Manadilli approximation shown below is used for all Uponor pipe head loss calculations.

$$f = \left[\frac{1}{-2 \cdot \log \left(\frac{E}{3.7 \cdot D} + \frac{95}{Re^{0.983}} - \frac{96.82}{Re} \right)} \right]^2$$

The friction factor can also be found by using a standard Moody Diagram. The Moody Diagram is a function of the Reynolds number and the ratio between pipe roughness and internal diameter. Below is a Moody Diagram created for PEX pipe.

Moody Diagram for ASTM PEX by pipe size — Manadilli Approximation

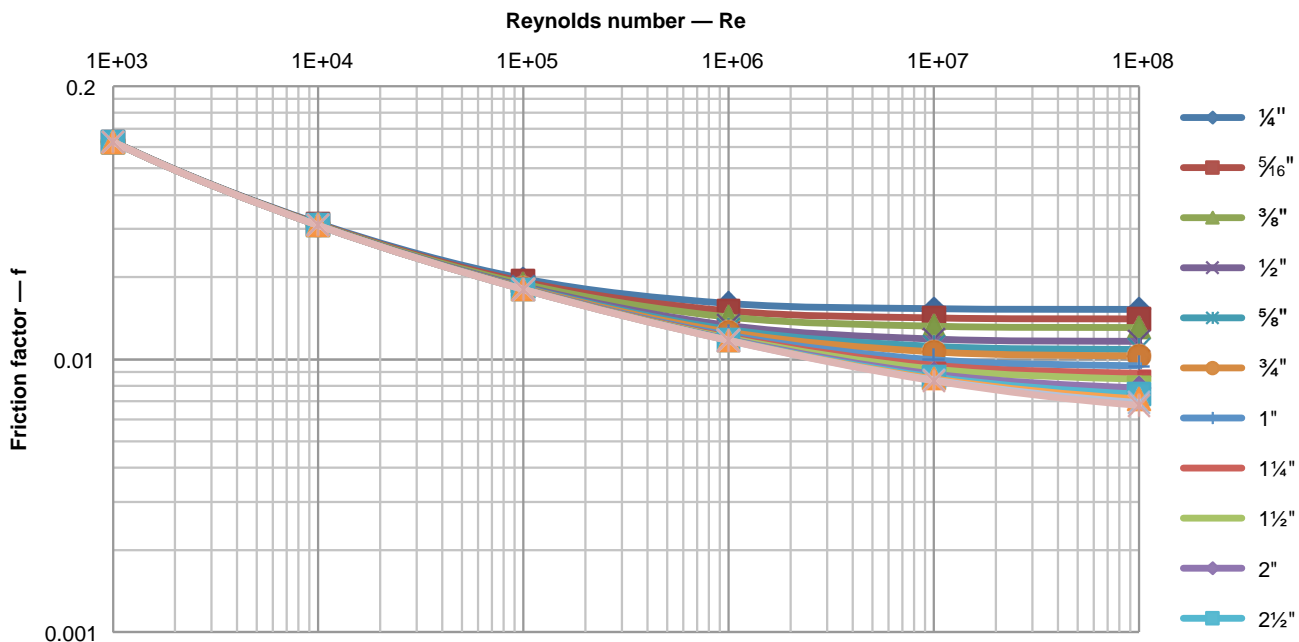

Figure 4-6: Moody diagram for ASTM PEX by pipe size

Pressure differential

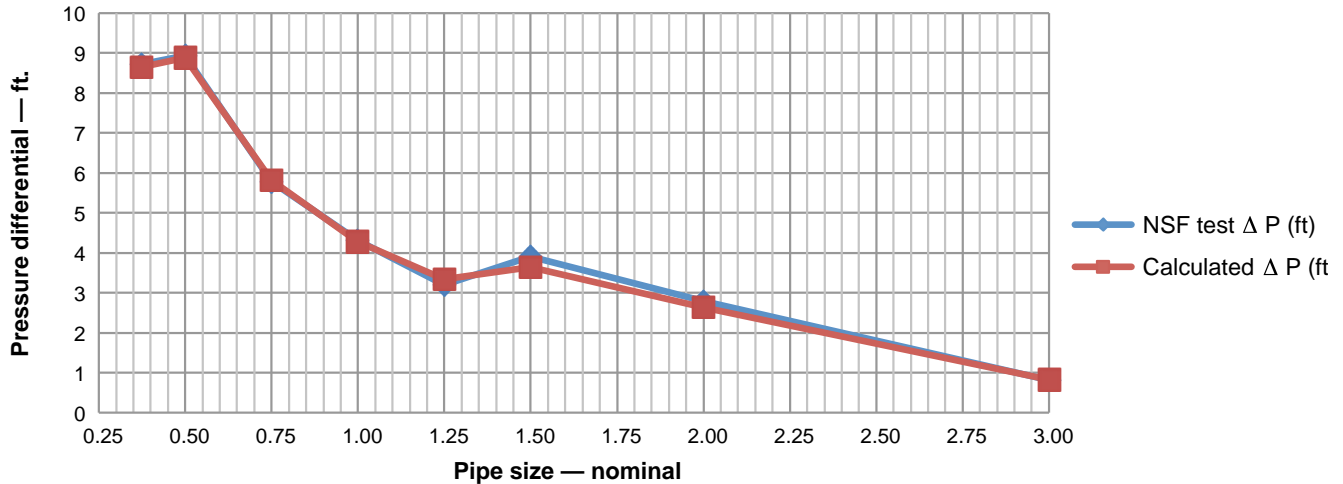

Figure 4-7: Friction loss comparing Darcy-Weisbach vs. NSF test data

Hazen-Williams method

The Hazen-Williams method is another method for sizing PEX. However, it is not preferred by Uponor (especially for heating and cooling system sizing). Like the Darcy-Weisbach formula, this formulation is also based

on empirical relationships with water flowing through pipes.

However, correlation with test data is much more limited. This formulation set was derived for fire sprinkler design and

large water supply networks with 3" and larger piping. It is also strictly for 100 percent water and does not account for temperature and fluid viscosity.

Since its development,

additional temperature correction and fluid correction factors have been established. However, results can show significant error when compared to test data.

The following equation shows the Hazen-Williams method.

$$h_f = 0.2083 \cdot \left(\frac{100}{C} \right)^{1.852} \cdot \frac{q^{1.852}}{D^{4.8655}}$$

Where,

$$h_f = \text{head loss due to friction per } 100 \text{ ft} \left(\frac{\text{ft}_{\text{water}}}{100 \text{ ft}_{\text{pipe}}} \right)$$

C = Hazen-Williams roughness constant

The Hazen-Williams roughness constant for Uponor PEX-a is 163.

q = volumetric flow rate (gpm)

D = internal pipe diameter (in)

Comparing Darcy-Weisbach and Hazen-Williams

NSF performed testing to calculate the friction loss of Uponor PEX pipe and Uponor ProPEX fittings. The testing allowed Uponor to analyze empirical test data and compare it with the Darcy-Weisbach and Hazen-Williams methods.

The following graph illustrates the comparison.

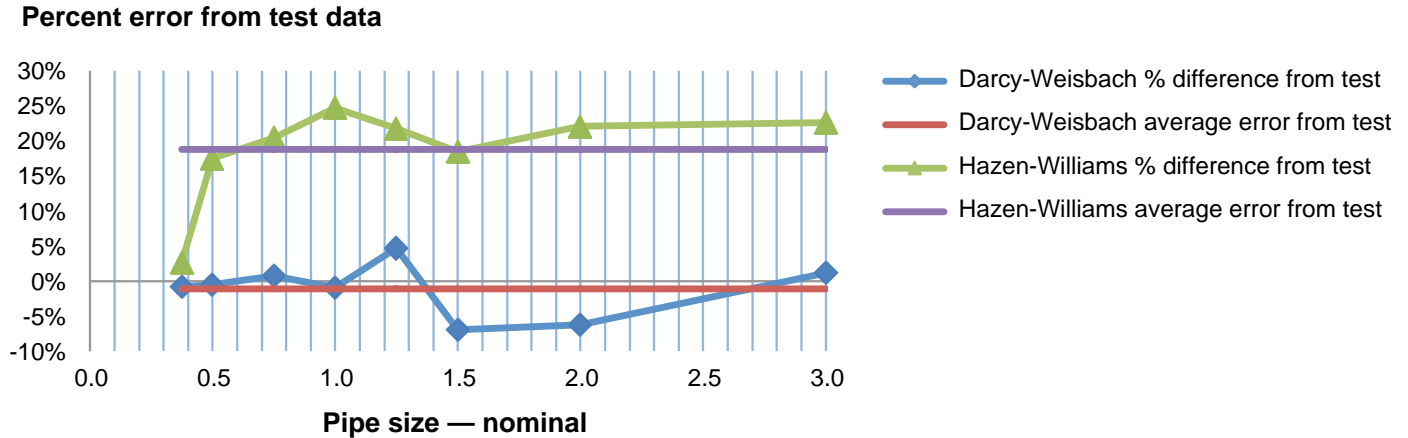

Figure 4-8: Darcy-Weisbach and Hazen-Williams comparison

The Y axis represents the percent error from the test data; the X axis represents nominal pipe size. The graph shows the average error when using the Darcy-Weisbach method is less than 1 percent when compared to the test data. The Hazen-Williams method, however, yields an 18 percent average error compared to the test data.

Note: The test was performed with 70°F (21.1°C), 100 percent water.

Friction loss of fittings

There are two commonly accepted methods when analyzing pressure loss or head loss of fittings. The first and preferred method uses C_v values to precisely calculate

fittings losses. The C_v value represents how many gpm can flow through a fitting at 1 psi pressure drop.

For example, a fitting with a C_v of 5.0 would flow 5.0 gpm at a 1 psi pressure drop across the

fitting. Since C_v is a function of flow rate versus pressure drop, it yields an accurate representation of fitting friction loss. The second method uses equivalent lengths. Uponor has created charts for both equivalent length and

C_v . The equivalent lengths were developed using a flow velocity of 8 fps.

The C_v method for calculating friction loss

C_v is a function of flow rate versus pressure drop across the fitting. It also accounts for the density of the fluid.

Refer to the following friction loss calculation using the C_v method.

$$\Delta P = \left(\frac{P_f}{P_w} \right) \left(\frac{F}{C_v} \right)^2$$

Where,

ΔP = pressure drop across the fitting (psi)

P_f = fluid density $\left(\frac{lb}{ft^3} \right)$

P_w = density of water at 60°F $\left(\frac{lb}{ft^3} \right)$

The density of water at 60°F (15.6°C) is 62.38 pounds per cubic foot.

F = volumetric flow rate through the fitting (gpm)

C_v = known C_v rating of the fitting

This calculation yields a value in pounds per square inch which, for hydronic sizing, needs to be converted to feet of head as 100 percent water.

The conversion to feet of water is shown below.

$$h_f = \frac{144in^2 \cdot \Delta P}{1ft^3 \cdot P_f}$$

Where,

h_f = head loss due to friction across the fitting (ft)

P_f = fluid density $\left(\frac{lb}{ft^3} \right)$

ΔP = pressure drop across the fitting (psi)

This value can be cumulatively added to the values from the other fittings in the distribution line to calculate the total loss for the fittings in the system.

Example 2

For a given elbow with a C_v of 6.7 and a flow rate of 3.5 gpm at a water temperature of 160°F (71.1°C), what is the friction loss of the fitting (in feet)?

Assuming the fluid is 100 percent water, here is the calculation.

$$P_f = 60.99 \frac{lb}{ft^3}$$

$$F = 3.5 \text{ gpm}$$

$$C_v = 6.7$$

$$\Delta P = \left(\frac{P_f}{P_w} \right) \left(\frac{F}{C_v} \right)^2 = \left(\frac{60.99 \frac{lb}{ft^3}}{62.38 \frac{lb}{ft^3}} \right) \left(\frac{3.5 \text{ gpm}}{6.7} \right)^2 = 0.267 \text{ psi}$$

Note: To make the units work in the C_v formula, it must be assumed the C_v has the units of gpm and the result multiplied by 1 psi.

With the pressure differential known, the value found can be converted to head loss in feet as seen below.

$$h_f = \frac{144in^2 \cdot \Delta P}{1ft^2 \cdot P_f} = \frac{144in^2 \cdot 0.267 \text{ psi}}{1ft^2 \cdot 60.99 \frac{lb}{ft^3}} = 0.63 \text{ ft}$$

UPC table 610.4

Tables taken from IAPMO ER 0253

**TABLE 610.4
FIXTURE UNIT TABLE FOR DETERMINING WATER PIPE AND METER SIZES**

METER AND STREET SERVICE (inches)	BUILDING SUPPLY AND BRANCHES (inches)	MAXIMUM ALLOWABLE LENGTH (feet)															
		40	60	80	100	150	200	250	300	400	500	600	700	800	900	1000	
PRESSURE RANGE – 30 to 45 psi¹																	
¾	½ ²	6	5	4	3	2	1	1	1	0	0	0	0	0	0	0	
¾	¾	16	16	14	12	9	6	5	5	4	4	3	2	2	2	1	
¾	1	29	25	23	21	17	15	13	12	10	8	6	6	6	6	6	
1	1	36	31	27	25	20	17	15	13	12	10	8	6	6	6	6	
¾	1¼	36	33	31	28	24	23	21	19	17	16	13	12	12	11	11	
1	1¼	54	47	42	38	32	28	25	23	19	17	14	12	12	11	11	
1½	1¼	78	68	57	48	38	32	28	25	21	18	15	12	12	11	11	
1	1½	85	84	79	65	56	48	43	38	32	28	26	22	21	20	20	
1½	1½	150	124	105	91	70	57	49	45	36	31	26	23	21	20	20	
2	1½	151	129	129	110	80	64	53	46	38	32	27	23	21	20	20	
1	2	85	85	85	85	85	85	82	80	66	61	57	52	49	46	43	
1½	2	220	205	190	176	155	138	127	120	104	85	70	61	57	54	51	
2	2	370	327	292	265	217	185	164	147	124	96	70	61	57	54	51	
2	2½	445	418	390	370	330	300	280	265	240	220	198	175	158	143	133	
PRESSURE RANGE – 46 to 60 psi¹																	
¾	½ ²	7	7	6	5	4	3	2	2	1	1	1	0	0	0	0	
¾	¾	20	20	19	17	14	11	9	8	6	5	4	4	3	3	3	
¾	1	39	39	36	33	28	23	21	19	17	14	12	10	9	8	8	
1	1	39	39	39	36	30	25	23	20	18	15	12	10	9	8	8	
¾	1¼	39	39	39	39	39	39	34	32	27	25	22	19	19	17	16	
1	1¼	78	78	76	67	52	44	39	36	30	27	24	20	19	17	16	
1½	1¼	78	78	78	78	66	52	44	39	33	29	24	20	19	17	16	
1	1½	85	85	85	85	85	85	80	67	55	49	41	37	34	32	30	
1½	1½	151	151	151	151	128	105	90	78	62	52	42	38	35	32	30	
2	1½	151	151	151	151	150	117	98	84	67	55	42	38	35	32	30	
1	2	85	85	85	85	85	85	85	85	85	85	85	85	85	85	83	80
1½	2	370	370	340	318	272	240	220	198	170	150	135	123	110	102	94	
2	2	370	370	370	370	368	318	280	250	205	165	142	123	110	102	94	
2	2½	654	640	610	580	535	500	470	440	400	365	335	315	285	267	250	
PRESSURE RANGE – Over 60 psi¹																	
¾	½ ²	7	7	7	6	5	4	3	3	2	1	1	1	1	1	0	
¾	¾	20	20	20	20	17	13	11	10	8	7	6	6	5	4	4	
¾	1	39	39	39	39	35	30	27	24	21	17	14	13	12	12	11	
1	1	39	39	39	39	38	32	29	26	22	18	14	13	12	12	11	
¾	1¼	39	39	39	39	39	39	39	39	34	28	26	25	23	22	21	
1	1¼	78	78	78	78	74	62	53	47	39	31	26	25	23	22	21	
1½	1¼	78	78	78	78	78	74	65	54	43	34	26	25	23	22	21	
1	1½	85	85	85	85	85	85	85	85	81	64	51	48	46	43	40	
1½	1½	151	151	151	151	151	151	130	113	88	73	51	51	46	43	40	
2	1½	151	151	151	151	151	151	142	122	98	82	64	51	46	43	40	
1	2	85	85	85	85	85	85	85	85	85	85	85	85	85	85	85	
1½	2	370	370	370	370	360	335	305	282	244	212	187	172	153	141	129	
2	2	370	370	370	370	370	370	370	340	288	245	204	172	153	141	129	
2	2½	654	654	654	654	654	650	610	570	510	460	430	404	380	356	329	

For SI units: 1 inch = 25 mm, 1 foot = 304.8 mm, 1 pound-force per square inch = 6.8947 kPa

Notes:

¹ Available static pressure after head loss.

² Building supply, not less than ¾ of an inch (20 mm) nominal size.

IPC table E201.1

Tables taken from ICC-ES-PMG 1006

Table E201.1
Minimum size of water meters, mains and distribution piping based on
water supply fixture unit values (w.s.f.u.)

Meter and service pipe (inches)	Distribution pipe (inches)	Maximum development length (feet)									
		40	60	80	100	150	200	250	300	400	500
Pressure range 30 to 39 psi											
¾	½ ^a	2.5	2	1.5	1.5	1	1	0.5	0.5	0	0
¾	¾	9.5	7.5	6	5.5	4	3.5	3	2.5	2	1.5
¾	1	32	25	20	16.5	11	9	7.8	6.5	5.5	4.5
1	1	32	32	27	21	13.5	10	8	7	5.5	5
¾	1¼	32	32	32	32	30	24	20	17	13	10.5
1	1¼	80	80	70	61	45	34	27	22	16	12
1½	1¼	80	80	80	75	54	40	31	25	17.5	13
1	1½	87	87	87	87	84	73	64	56	45	36
1½	1½	151	151	151	151	117	92	79	69	54	43
2	1½	151	151	151	151	128	99	83	72	56	45
1	2	87	87	87	87	87	87	87	87	87	86
1½	2	275	275	275	275	258	223	196	174	144	122
2	2	365	365	365	365	318	266	229	201	160	134
2	2½	533	533	533	533	533	495	448	409	353	311

Meter and service pipe (inches)	Distribution pipe (inches)	Maximum development length (feet)									
		40	60	80	100	150	200	250	300	400	500
Pressure range 40 to 49 psi											
¾	½ ^a	3	2.5	2	1.5	1.5	1	1	0.5	0.5	0.5
¾	¾	9.5	9.5	8.5	7	5.5	4.5	3.5	3	2.5	2
¾	1	32	32	32	26	18	13.5	10.5	9	7.5	6
1	1	32	32	32	32	21	15	11.5	9.5	7.5	6.5
¾	1¼	32	32	32	32	32	32	32	27	21	16.5
1	1¼	80	80	80	80	65	52	42	35	26	20
1½	1¼	80	80	80	80	75	59	48	39	28	21
1	1½	87	87	87	87	87	87	87	78	65	55
1½	1½	151	151	151	151	151	130	109	93	75	63
2	1½	151	151	151	151	151	139	115	98	77	64
1	2	87	87	87	87	87	87	87	87	87	87
1½	2	275	275	275	275	275	275	264	238	198	169
2	2	365	365	365	365	365	349	304	270	220	185
2	2½	533	533	533	533	533	533	533	528	456	403

For SI: 1 inch = 25.4mm, 1 foot = 304.8mm.

^aMinimum size for building supply is ¾-inch pipe.

(continued)

IPC table E201.1

Tables taken from ICC-ES-PMG 1006

Table E201.1 (continued)
Minimum size of water meters, mains and distribution piping based on
water supply fixture unit values (w.s.f.u.)

Meter and service pipe (inches)	Distribution pipe (inches)	Maximum development length (feet)										
		40	60	80	100	150	200	250	300	400	500	
Pressure range 50 to 60 psi												
¾	½ ^a	3	3	2.5	2	1.5	1	1	1	0.5	0.5	
¾	¾	9.5	9.5	9.5	8.5	6.5	5	4.5	4	3	2.5	
¾	1	32	32	32	32	25	18.5	14.5	12	9.5	8	
1	1	32	32	32	32	30	22	16.5	13	10	8	
¾	1¼	32	32	32	32	32	32	32	32	29	24	
1	1¼	80	80	80	80	80	68	57	48	35	28	
1½	1¼	80	80	80	80	80	75	63	53	39	29	
1	1½	87	87	87	87	87	87	87	87	82	70	
1½	1½	151	151	151	151	151	151	139	120	94	79	
2	1½	151	151	151	151	151	151	146	126	97	81	
1	2	87	87	87	87	87	87	87	87	87	87	
1½	2	275	275	275	275	275	275	275	275	247	213	
2	2	365	365	365	365	365	365	365	329	272	232	
2	2½	533	533	533	533	533	533	533	533	533	486	

Meter and service pipe (inches)	Distribution pipe (inches)	Maximum development length (feet)										
		40	60	80	100	150	200	250	300	400	500	
Pressure range over 60 psi												
¾	½ ^a	3	3	3	2.5	2	1.5	1.5	1	1	0.5	
¾	¾	9.5	9.5	9.5	9.5	7.5	6	5	4.5	3.5	3	
¾	1	32	32	32	32	32	24	19.5	15.5	11.5	9.5	
1	1	32	32	32	32	32	28	28	17	12	9.5	
¾	1¼	32	32	32	32	32	32	32	32	32	30	
1	1¼	80	80	80	80	80	80	69	60	46	36	
1½	1¼	80	80	80	80	80	80	76	65	50	38	
1	1½	87	87	87	87	87	87	87	87	87	84	
1½	1½	151	151	151	151	151	151	151	144	114	94	
2	1½	151	151	151	151	151	151	151	151	118	97	
1	2	87	87	87	87	87	87	87	87	87	87	
1½	2	275	275	275	275	275	275	275	275	275	252	
2	2	365	368	368	368	368	368	368	368	318	273	
2	2½	533	533	533	533	533	533	533	533	533	533	

For SI: 1 inch = 25.4mm, 1 foot = 304.8mm.

^aMinimum size for building supply is ¾-inch pipe.

NPCC table A-2.6.3.1(2)A

Tables taken from NPCC

Current Table A-2.6.3.1.(2)A, Pressure Range 200-310 kPa

Water Service Pipe Size in.	Water Distribution Pipe Size in.	Maximum Allowable Length, meters														
		12	18	24	30	46	61	76	91	122	152	183	213	244	274	305
Pressure Range		Number of Fixture Units Served														
200 to 310 kPa		Flow Velocity, m/s: 3.0 2.4 1.5														
3/4	1/2	6	5	4	3	2	1	0	0	0	0	0	0	0	0	0
3/4	5/8	12	10	9	7	5	3	3	3	2	2	1	1	1	1	0
3/4	3/4	18	16	14	12	9	6	5	5	4	4	3	2	2	2	1
1	1	36	31	27	25	20	17	15	13	12	10	8	6	6	6	6
1-1/2	1-1/4	83	68	57	48	38	32	28	25	21	18	15	12	12	11	11
1-1/2	1-1/2	151	124	105	91	70	57	49	45	36	31	26	23	21	20	20
2	1-1/2	151	151	132	110	80	64	53	46	38	32	27	23	21	20	20
2	2	359	329	292	265	217	185	164	147	124	96	70	61	57	54	51
2-1/2	2-1/2	445	418	390	370	330	300	280	265	240	220	198	175	158	143	133

Current Table A-2.6.3.1.(2)A, Pressure Range 311-413 kPa

Water Service Pipe Size in.	Water Distribution Pipe Size in.	Maximum Allowable Length, meters														
		12	18	24	30	46	61	76	91	122	152	183	213	244	274	305
Pressure Range		Number of Fixture Units Served														
311 to 413 kPa		Flow Velocity, m/s: 3.0 2.4 1.5														
3/4	1/2	8	7	6	5	4	3	2	2	1	1	1	0	0	0	0
3/4	5/8	13	13	12	11	9	7	5	5	3	3	2	2	1	1	1
3/4	3/4	21	21	19	17	14	11	9	8	6	5	4	4	3	3	3
1	1	42	42	41	36	30	25	23	20	18	15	12	10	9	8	8
1-1/2	1-1/4	83	83	83	83	66	52	44	39	33	29	24	20	19	17	16
1-1/2	1-1/2	151	151	151	151	128	105	90	78	62	52	42	38	35	32	30
2	1-1/2	151	151	151	151	150	117	98	84	67	55	42	38	35	32	30
2	2	359	359	359	359	359	318	280	250	205	165	142	123	110	102	94
2-1/2	2-1/2	611	611	610	580	535	500	470	440	400	365	335	315	285	267	250

Current Table A-2.6.3.1.(2)A, Pressure Range Over 413 kPa

Water Service Pipe Size in.	Water Distribution Pipe Size in.	Maximum Allowable Length, meters														
		12	18	24	30	46	61	76	91	122	152	183	213	244	274	305
Pressure Over		Number of Fixture Units Served														
413 kPa		Flow Velocity, m/s: 3.0 2.4 1.5														
3/4	1/2	8	8	7	6	5	4	3	3	2	1	1	1	1	1	0
3/4	5/8	13	13	13	13	11	8	7	6	5	4	3	3	3	2	2
3/4	3/4	21	21	21	21	17	13	11	10	8	7	6	6	5	4	4
1	1	42	42	42	42	38	32	29	26	22	18	14	13	12	12	11
1-1/2	1-1/4	83	83	83	83	83	74	62	54	43	34	26	25	23	22	21
1-1/2	1-1/2	151	151	151	151	151	151	130	113	88	73	51	51	46	43	40
2	1-1/2	151	151	151	151	151	151	142	122	98	82	64	51	46	43	40
2	2	359	359	359	359	359	359	359	340	288	245	204	172	153	141	129
2-1/2	2-1/2	611	611	611	611	611	611	610	570	510	460	430	404	380	356	329

NPCC table 2.6.3.2

Reproduced with the permission of the National Research Council of Canada, copyright holder.

2.6.3.2. Hydraulic Load

- 1) Except as provided in Sentence (3), the hydraulic load of a *fixture* or device that is listed in Table 2.6.3.2.A. shall be the number of *fixture units* given in the Table.
- 2) Except as provided in Sentences (1) and (3), the hydraulic load of a *fixture* that is not listed in Table 2.6.3.2.A. is the number of *fixture units* listed in Table 2.6.3.2.D.
- 3) Where *fixtures* are supplied with both hot and cold water, the hydraulic loads for maximum separate demands shall be 75% of the hydraulic load of the *fixture units* given in Tables 2.6.3.2.A. and 2.6.3.2.D. when using a detailed engineering design method.
- 4) The hydraulic load of urinals and water closets with direct flush valves shall be the number of *fixture units* listed in Tables 2.6.3.2.B. and 2.6.3.2.C. (See Appendix A.)

Table 2.6.3.2.A.
Sizing of Water Distribution Systems^{(1) (2)}

Forming Part of Sentences 2.6.3.2.(1), (2) and (3), and 2.6.3.4.(2), (3) and (5)

Fixture or Device	Minimum Size of Supply Pipe, inches	Private Use Hydraulic Load, fixture units			Public Use Hydraulic Load, fixture units		
		Cold	Hot	Total	Cold	Hot	Total
Bathroom group with 6 LPF flush tank ⁽³⁾	n/a	2.7	1.5	3.6	-	-	-
Bathroom group with greater than 6 LPF flush tank ⁽³⁾	n/a	4	3	6	-	-	-
Bathroom group with more than 3 fixtures	-	-	-	(4)	-	-	-
Bathtub with or without shower head	½	1	1	1.4	3	3	4
Bathtub with ¾ inch spout	¾	7.5	7.5	10	7.5	7.5	10
Bedpan washer	1	-	-	-	7.5	7.5	10
Bidet	⅜	1.5	1.5	2	-	-	-
Cothèse washer 3.5 kg	½	1	1	1.4	2.25	2.25	3
Clothes washer 6.8 kg	½	-	-	-	3	3	4
Cothèse washer, commercial ⁽⁵⁾	-	-	-	-	-	-	-
Dental lavatory	⅜	-	-	-	1.5	1.5	2
Dental unit, cuspidor	⅜	-	-	-	1	-	1
Dishwasher, commercial ⁽⁵⁾	-	-	-	-	-	-	-
Dishwasher, domestic	⅜	-	1.4	1.4	-	-	-
Drinking fountain or water cooler	⅜	-	-	-	0.25	-	0.25
Hose bibb	½	2.5	-	2.5	2.5	-	2.5
Hose bibb	¾	3	-	3	6	-	6
Hose bibb, combination hot and cold	½	1.9	1.9	2.5	1.9	1.9	2.5
Lavatory, 8.3 LPM or less	⅜	0.5	0.5	0.7	1.5	1.5	2
Lavatory, greater than 8.3 LPM	⅜	0.75	0.75	1	1.5	1.5	2
Sink, bar	⅜	0.75	0.75	1	1.5	1.5	2
Sink, clinic service faucet	½	-	-	-	2.25	2.25	3
Sink, clinic service with direct flush valve	1	-	-	-	6	-	6
Sink, kitchen commercial, per faucet	½	-	-	-	3	3	4
Sink, kitchen domestic, 8.3 LPM	⅜	1	1	1.4	1	1	1.4

NPCC table 2.6.3.2

Reproduced with the permission of the National Research Council of Canada, copyright holder.

Fixture or Device	Minimum Size of Supply Pipe, inches	Private Use Hydraulic Load, fixture units			Public Use Hydraulic Load, fixture units		
		Cold	Hot	Total	Cold	Hot	Total
Sink, kitchen domestic, greater than 8.3 LPM	3/8	1.5	1.5	2	1.5	1.5	2
Sink, laboratory	3/8	-	-	-	1.5	1.5	2
Sink, laundry (1 or 2 compartments)	3/8	1	1	1.4	1	1	1.4
Sink, service or mop basin	1/2	-	-	-	2.25	2.25	3
Sink, washup, per faucet	1/2	-	-	-	1.5	1.5	2
Shower head, 9.5 LPM or less per head	1/2	1	1	1.4	3	3	4
Shower head, greater than 9.5 LPM per head	1/2	1.5	1.5	2	3	3	4
Shower, spray, multi-head, fixture unit per head	(5)	1	1	1.4	3	3	4
Urinal, with direct flush valve	3/4	(6)	-	(6)	(6)	-	(6)
Urinal, with flush tank	3/8	3	-	3	3	-	3
Urinal, with self-closing metering valve	1/2	2	-	2	4	-	4
Water closet, 6 LPF or less with flush tank	3/8	2.2	-	2.2	2.2	-	2.2
Water closet, greater than 6 LPF with flush tank	3/8	3	-	3	5	-	5
Water closet, with direct flush valve	1	(6)	-	(6)	(6)	-	(6)

Notes to Table 2.6.3.2.A.:

- (1) The fixture unit values in this Table are not applicable in certain assembly occupancies because of surges in use by the occupants. For such occupancies, refer to specific design information.
- (2) For fixtures not indicated in this Table, refer to Table 2.6.3.2.D.
- (3) Bathroom group is based on a 1/2-inch size bathtub supply pipe.
- (4) Add additional fixture to the fixture load for bathroom group.
- (5) Refer to manufacturer's recommendations.
- (6) For fixture unit values for fixtures with direct flush valves, see Sentence 2.6.3.2.(4) and Tables 2.6.3.2.B. and 2.6.3.2.C.

Table 2.6.3.2.B.
Sizing of Water Distribution Systems for Urinals with Direct Flush Valves
 Forming Part of sentences 2.6.3.2.(4) and 2.6.3.4.(5)

Number of Valves	Individual Fixture Unit Assigned in Decreasing Value	Fixture Units in Accumulative Values ⁽¹⁾
1	20	20
2	15	35
3	10	45
4	8	53
5 or more	5 each	58, plus 5 for each additional fixture in excess of 5

Notes to Table 2.6.3.2.B.:

- (1) The accumulative fixture unit values are the total values to be used in conjunction with Table 2.6.3.2.A.

NPCC table 2.6.3.2

Reproduced with the permission of the National Research Council of Canada, copyright holder.

Number of Valves	Individual Fixture Unit Assigned in Decreasing Values	Fixture Units in Accumulative Values ⁽¹⁾
1	40	40
2	30	70
3	20	90
4	15	105
5 or more	10 for each public use and 6 for each private use	115, plus 10 for each public use additional fixture excess of 5 and 111, plus 6 for each private use additional fixture in excess of 5

Notes to Table 2.6.3.2.C.:

(1) The accumulative fixture unit values are the total values to be used in conjunction with Table 2.6.3.2.A.

Table 2.6.3.2.D.
Hydraulic Loads of Fixtures Not Listed in Table 2.6.3.2.A.
Forming Part of Sentences 2.6.3.2.(2) and 2.6.3.4.(5)

Size of Supply Pipe, Inches	Hydraulic Load, fixture units	
	Private use	Public use
$\frac{3}{8}$	1	2
$\frac{1}{2}$	2	4
$\frac{3}{4}$	3	6
1	6	10

2.6.3.3. Static Pressure

- 1) Where the static pressure at any *fixture* may exceed 550 kPa, a pressure-reducing valve shall be installed to limit the maximum static pressure at the *fixture* to 550 kPa.

2.6.3.4. Size

- 1) Every *water service pipe* shall be sized according to the peak demand flow but shall not be less than $\frac{3}{4}$ inch *size*.
- 2) Except as provided in Sentence (3), the *size* of a supply pipe that serves a *fixture* shall conform to Table 2.6.3.2.A.
- 3) For *fixtures* listed in Table 2.6.3.2.A. that have a permitted supply pipe *size* of $\frac{3}{8}$ inch, a connector not more than 750mm long and not less than 6.3mm inside diameter may be used to supply water to the *fixture*.
- 4) No *water system* between the point of connection with the *water service pipe* or the water meter and the first *branch* that supplies a water heater that serves more than one *fixture* shall be sized less than $\frac{3}{4}$ inch.
- 5) Where both hot and cold water is supplied to *fixtures* in residential *buildings* containing one or two *dwelling* units or row houses with separate *water service pipes*, the *water system* may be sized in accordance with Table 2.6.3.4., where
 - a) the hydraulic loads for maximum separate demands on *water distribution system* piping are not less than 100% of the total hydraulic load of the *fixture units* given in Tables 2.6.3.2.A., 2.6.3.2.B., 2.6.3.2.C. or 2.6.3.2.D. for *private use*,
 - b) the minimum water pressure at the entry to the building is 200 kPa, and
 - c) the total maximum length of *water system* is 90 m.

Chapter 5:

System design and layout

This section profiles potable-water design and layout techniques that are primarily found in multi-family and commercial buildings, generally referred to as fire-resistant construction buildings, where both plumbing and building codes apply.

The Uponor advantage

Designing a building's domestic-water system with Uponor AquaPEX piping and ProPEX fittings delivers a system with many advantages: reliability, cost-effectiveness and code-compliance from a system that meets peak flow demands while conserving water and energy.

Utilizing the smaller inside diameter of SDR9 Uponor PEX piping allows decreased system volume, therefore providing hot water to fixtures in a shorter amount of time

while still meeting end-use fixture requirements. The superior qualities of Uponor PEX deliver a lifetime of corrosion-free system performance.

Designing with multipoint tees and small-dimension ($\frac{1}{2}$ " to 1") coiled piping reduces the number of behind-the-wall connections in a unit application by 70 percent. Fewer connections mean faster installation times and fewer potential leak points.

Additional features such as a resistance to freeze damage, heat-kink repairability, stable material cost, superior thermal and acoustical properties, and a 25-year limited warranty give the designer additional confidence in choosing an Uponor AquaPEX plumbing system.

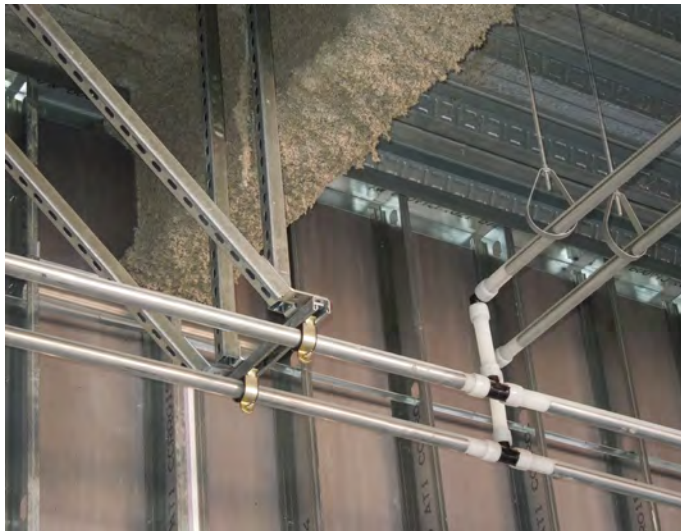

Figure 5-1: Uponor PEX-a Pipe Support



Figure 5-2: In-wall piping

Unit/In-suite piping

Uponor AquaPEX pipe for distributing water to fixtures may be installed overhead, through framing, in slab or below grade. Common design methods for unit piping in multi-family commercial buildings include:

- Trunk and branch
- Home run
- Uponor Logic

Uponor Logic plumbing

Uponor Logic is the smart way to plumb, using flexible Uponor PEX pipe and multiport tees to minimize connections and maximize system performance. With an Uponor Logic layout, plumbing systems typically require fewer fittings than a trunk and branch design and less pipe than a home run layout.

Uponor Logic	
Number of fittings	9
Number of connections	33
Nominal pipe size	Length (ft.)
1/2"	261
3/4"	38
1"	5
Total	304

Table 5-1: Uponor Logic pipe and fittings usage

Home run	
Number of fittings	7
Number of connections	27
Nominal pipe size	Length (ft.)
1/2"	475
3/4"	30
1"	5
Total	510

Table 5-2: Home run pipe and fittings usage

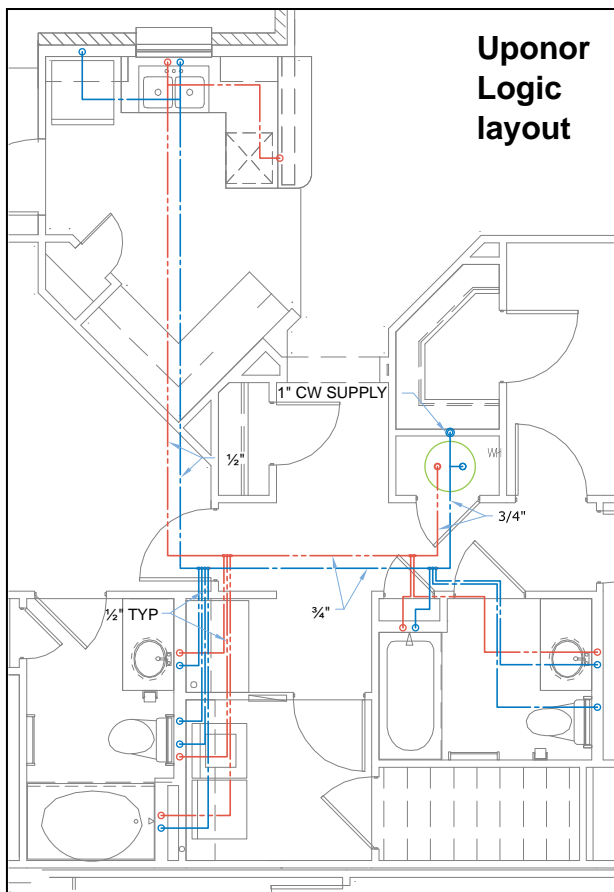

Figure 5-3: Uponor Logic layout

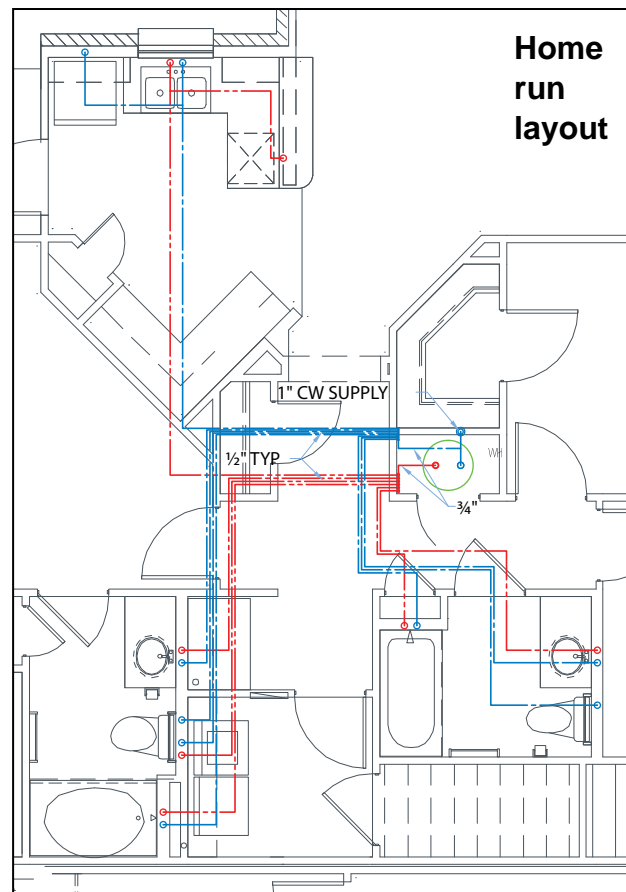

Figure 5-4: Home run layout

Critical path = HWS — W.H. to tub **UPC tub** = 4 wsfu = 4 gpm
CWS = 60°F **HWS** = 120°F **Mixed** = 110°F **Hot-water multiplier** = 0.83 = 3.32 gpm

System type	I.D. (in.)		Distance (ft.)		Volume (gal.)			Velocity (ft./sec.)		Pressure loss (psi)			First-use HW time to fixture
	1/2"	3/4"	1/2"	3/4"	1/2"	3/4"	Total	1/2"	3/4"	1/2"	3/4"	Total	Critical path (tub only)
Copper T&B	0.527	0.745	13	33	0.147	0.746	0.893	4.8	2.43	1.22	0.561	1.781	16.1 sec.
Home run	0.475	0.671	32	9	0.294	0.165	0.459	5.8	3	4.16	0.252	4.412	8.3 sec.
Uponor Logic	0.475	0.671	19	17	0.174	0.312	0.486	5.8	3	2.47	0.476	2.946	8.7 sec.

Table 5-3: Performance comparisons

Copper trunk and branch	
Number of fittings	39
Number of connections	93
Nominal pipe size	Length (ft.)
1/2"	234
3/4"	73
1"	5
Total	312

Table 5-4: Copper trunk and branch pipe and fittings usage

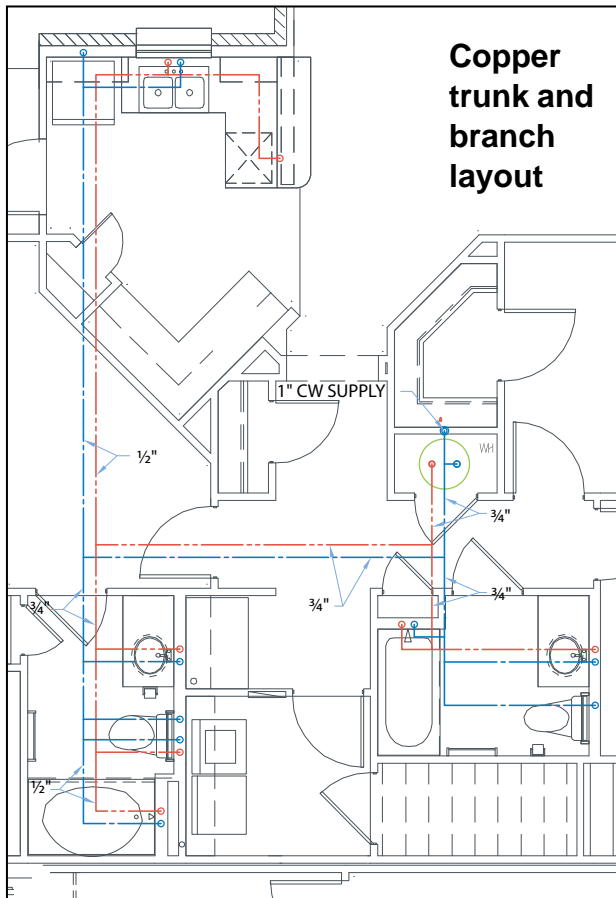

Figure 5-5: Copper trunk and branch layout

Efficiencies of Uponor Logic

For unit and in-suite applications, Uponor Logic reduces the number of fittings by up to 70 percent when compared to copper trunk and branch and requires 40 percent less tubing than a home run system. Uponor offers a full line of EP multiport tees for ultimate design flexibility.

Hot-water performance

Uponor Logic delivers hot water nearly 46 percent faster than a copper trunk and branch system for the first-use fixture and nearly 43 percent faster than a home run system for the second-use fixture.

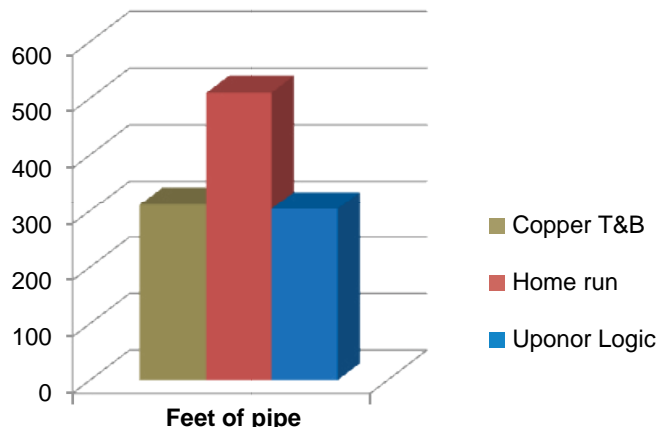
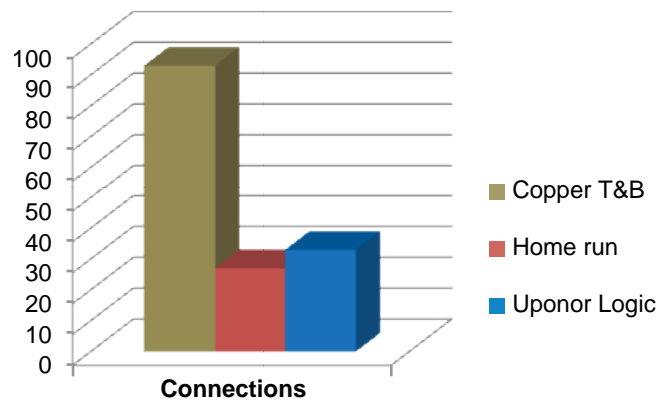
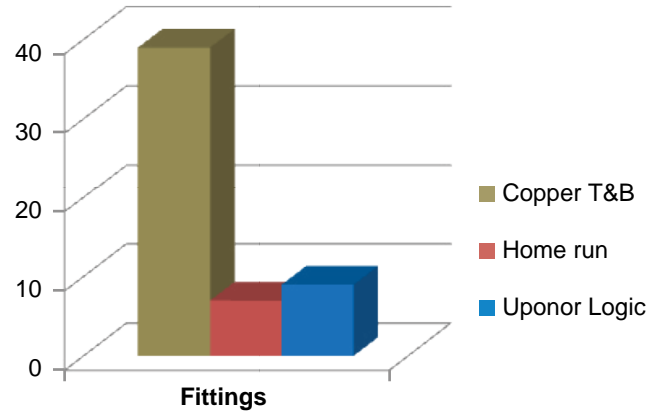

System type	First-use HW time to fixture	Second-use HW time to fixture
	Critical path (tub only)	Critical path (lav only)
Copper T&B	16.1 sec.	4.2 sec.
Home run	8.3 sec.	7.5 sec.
Uponor Logic	8.7 sec.	4.3 sec.

Table 5-5: Hot water time-to-fixture comparisons

Reverse osmosis and de-ionized water systems

Reverse-osmosis systems and systems using de-ionized water for drinking water applications are approved for use with Uponor AquaPEX piping granted the pH is between 5 and 8 and the maximum temperature does not exceed 140°F (60°C). Uponor requires the use of EP or stainless-steel fittings with de-ionized and reverse-osmosis water.

For process water applications such as clean labs and other industrial-type pure water applications, please contact Uponor for more information.

Surge pressure and sound intensity

The main sources of sound in a water piping system are cavitation, surface roughness and water hammer caused by surge pressure. Typical polymers will absorb sound in the range of 10 dB/cm, whereas metals are on the order of 0.1 to 1.0 dB/cm. For a given change in velocity, the intensity of sound from copper pipe will be higher than that of PEX-a piping. Peak pressures caused by a quick-acting valve could be reduced by

18 percent to 40 percent by utilizing Uponor PEX instead of copper pipe.

When comparing the change in sound intensity when switching from copper to PEX piping, with all else remaining the same, the sound intensity in the radial outward direction is the primary area to evaluate.

Beginning with the general wave equation $I^2 p = (1/c^2)(M^2 p/M t^2)$ and some simplifying assumptions (e.g., point source of sound), the relationship for intensity can be derived with the following formula:

$$I = pv$$

Where:

I = sound intensity
p = sound pressure
v = particle velocity

Water hammer

Water hammer is probably the most significant concern and can be evaluated using the following:

$$A = 4660 / [1 + kD/(Et)]^{1/2}$$

Where:

A = Wave velocity
k = Bulk modulus of water (300,000 psi)
D = Inside diameter of pipe

E = Tensile modulus of pipe material

t = Wall thickness

For 1/2" nominal size piping, the dimension ratio (D/t) of PEX piping is approximately 7; it is approximately 11 for copper (Type K).

Assuming a PEX piping modulus of 250,000 psi and copper modulus of 16,000,000 psi, the wave velocity is:

PEX piping – 1,520 ft./sec.

Copper piping – 4,240 ft./sec.

The surge pressure is calculated as $P = Av/(2.31 g)$, where v is the water velocity prior to the valve closing and g = 32.2. Assuming this is also the sound pressure (i.e., no losses), the sound intensity can be calculated as: $I = (A^2)(v)/74.4$

For PEX piping, I = 31,000 (v)

For copper piping, I = 242,000 (v)

This demonstrates that for a given change in water velocity, the intensity of the sound

from copper piping will be approximately eight times that of the PEX piping. While some assumptions are made in reaching this conclusion, even a conservative estimate would give copper piping a sound intensity two to four times that of PEX piping.

Water hammer arrestors

When considering the need to install water hammer arrestors, there are two components of water hammer that are of significance: surge pressure and noise transmission. The intent of water hammer arrestors is to reduce the surge pressure to 150 psi and to minimize the amount of noise transmission.

The International Plumbing Code (IPC) and the Uniform Plumbing Code (UPC) both require water hammer arrestors at quick-closing valve locations. **Tables 5-6 and 5-7** show surge pressure for copper, chlorinated polyvinyl chloride (CPVC) and PEX.

Pipe material	Maximum measured pressure (psi)				
	2	2.5	3	4	6
1/2" Uponor PEX	136	150	169	193	244
1/2" PEX-b	143	168	177	212	274
1/2" CPVC	155	173	201	222	296
1/2" Type L Copper	194	239	266	318	422

Table 5-6: First peak pressure for each piping material and flow rate (cold water)

1. Pressure response measurements include 60 psi static pressure.
2. Closing speed of quick-acting valve estimated at 25 milliseconds.
3. Test performed at 54°F/12.2°C (cold water temperature).

Surge Pressure in Plumbing Pipe Materials, PPI Report # 3285

Pipe material	Maximum measured pressure (psi)				
	2	2.5	3	4	6
1/2" Uponor PEX	113	122	123	141	174
1/2" PEX-b	108	113	124	141	175
1/2" CPVC	142	157	174	203	252
1/2" Type L Copper	149	181	204	250	306

Table 5-7: First peak pressure for each piping material and flow rate (hot water)

1. Pressure response measurements include 60 psi static pressure.
2. Closing speed of quick-acting valve estimated at 25 milliseconds.
3. Test performed at 130°F/54.4°C (hot water temperature).

Surge Pressure in Plumbing Pipe Materials, PPI Report # 3285

These tables show the surge pressure in Uponor PEX is about 38 percent less than the surge pressure in copper. The main reason for the dramatic difference in these results is the flexibility of Uponor PEX piping. Because of its flexibility, Uponor PEX piping significantly dampens surge pressure.

Hot-water system design

Uponor AquaPEX piping is tested and listed to PEX 5106 NSF-pw (CL5). Per ASTM F876, the CL5 chlorine resistance rating is intended for an end-use condition of 100 percent at 140°F/60°C, which is the highest chlorine-resistance rating available through ASTM. Products marked with a '5' in the first digit of the four-digit code and also bearing the CL5 designation [e.g., PEX 5106 NSF-pw (CL5)] indicate the product is approved for use in continuous, domestic, hot-water circulation systems with up to 140°F/60°C water temperatures.

Recirculated hot-water systems

To maintain satisfactory temperatures, hot-water systems are often recirculated. Several recirculating methods are available:

- **Manual control** — Should be used only when hot water is needed 24 hours a day. If that is not the case, manual control is not cost-effective.
- **Thermostatic aquastat** — Used to shut off the pump during peak demands of hot water when circulation is not needed.
- **Timed** — Utilized during specific hours of operation when people are most likely to use hot-water fixtures.
- **Combination aquastat/timed** — Combines the capabilities of the aquastat system with timed control, reducing energy consumption.

Uponor AquaPEX is rated for use in continuous-circulation domestic-water systems with temperatures up to 140°F/60°C.

Sizing and maximum velocity

Uponor requires that the velocity of the dedicated recirculation piping shall not exceed 2 ft./sec. and that the hot-water piping system (which includes the recirculation lines) meets the following requirements stated in the *ASPE Plumbing Engineering Design Handbook, Volume 2, Plumbing Systems*:

1. Calculate the heat loss rates of the hot-water supply piping.
2. Calculate the heat loss rates of the hot-water circulating piping.
3. Calculate the circulation rates for all parts of the circulating piping and the total circulation rate required.
4. Determine the allowable uniform friction head loss and the total head required to overcome friction losses in the piping when the water is flowing at the required circulation rate.
5. Calculate the rates of flow for various piping sizes that will give the uniform pressure drop established in **Step 4**, and tabulate the results.
6. Size the system based upon the tabulation set up in **Step 5**.
7. With the sizes established in **Step 6**, repeat **Steps 2 through 6** as a check on the assumptions made.

While Uponor recommends the more accurate process above, the following streamlined method is also available:

1. Allow ½ gpm for each small hot-water riser (¾" to 1"), 1 gpm for each medium-sized hot-water riser (1¼" to 1½"), and 2 gpm for each large-sized hot-water riser (2" and larger).
2. Add 1 gpm for each group of 20 hot-water-supplied fixtures.

Balancing of recirculated hot-water systems

Circulated hot-water systems require balancing to maintain satisfactory system temperatures. If systems are not properly balanced, circulated water has the

tendency to short circuit through the shortest loop in the system, thus creating high velocities in that loop and resulting in hot water delays to remote loops. Hot-water recirculated lines should be insulated, and they typically require little flow to maintain satisfactory system temperatures. Uponor limits maximum velocity to 2 ft./sec. in dedicated hot-water return piping using Uponor AquaPEX (see **Table 5-8**).

For system balancing, use calibrated devices such as balancing valves. Each balancing valve requires a check valve, either in-line or incorporated into the balancing valve assembly, to prevent reverse flow.

Nominal pipe size	Velocity (ft./sec.)	Flow rate (gpm)	Friction loss per foot at 120°F/48.9°C
½"	2	1.1	0.0195
¾"	2	2.2	0.0126
1"	2	3.6	0.0092
1¼"	2	5.4	0.0072
1½"	2	7.5	0.0059
2"	2	12.9	0.0042
2½"	2	19.8	0.0033
3"	2	28.1	0.0026

Table 5-8: Uponor AquaPEX flow rates at 2 ft./sec.

Heat trace

Uponor approves the use of heat-trace cables with Uponor PEX products, provided the product has automatic thermostatic control capability and the temperature does not exceed the maximum rating listed on the piping (200°F/93.3°C). Wrap heat tape around the piping and secure the cable with plastic cable ties, not tape; then insulate with either closed-cell or fiberglass pipe insulation

Thermal conductivity

Uponor PEX pipe has a very low coefficient of thermal conductivity: 0.219 Btu/(h•ft•°F). In comparison, copper has a coefficient of thermal conductivity between 173 and 231 Btu/(h•ft•°F), depending on wall thickness (Type K, L or M). Therefore, Uponor PEX piping does not sweat like copper.

Nominal pipe size	R-value
½"	0.03
¾"	0.04
1"	0.052
1¼"	0.063
1½"	0.075
2"	0.098
2½"	0.122
3"	0.144

Table 5-9: SDR9 PEX R-value

Uponor PEX has superior insulating qualities when compared to copper in the same application. Even though the difference in R-value is relatively small, the higher R-value of Uponor PEX piping will always result in less heat loss than with the same nominal-size copper pipe.

Pipe	Btu/(h•ft•°F)
Copper	173-231
PEX-a	0.219
CPVC	0.079

Table 5-10: Thermal conductivity of piping materials

When comparing samples of the same thickness, CPVC has a lower thermal conductivity than Uponor PEX. To represent these values in the form of a pipe wall, we must compare the conductivity through a CTS SDR9 Uponor PEX pipe wall to that of a CTS SDR11 CPVC wall; SDR9 is 22 percent thicker than SDR11.

When conductivity is applied to the pipe wall thickness, Uponor PEX is within two percent of the thermal resistance of CPVC.

Insulation

Uponor recommends insulating all domestic hot-water supply and return piping as well as any hydronic heating and cooling piping to conserve energy and maintain desired fluid temperature. Uponor also recommends insulating any piping installed in an unconditioned space or poorly ventilated areas with excessive moisture content. Always comply with local and energy codes.

Pre-insulated Uponor AquaPEX piping

Pre-insulated Uponor AquaPEX piping, which is available in coils or straight lengths, features closed-cell polyethylene insulation to make hot and cold potable-water distribution systems more efficient. The insulation can also help meet energy-code requirements; check with local code authorities regarding energy-code requirements for specific applications.

Pre-insulated Uponor AquaPEX is available in the following sizes:

- ½" to 2" with ½" thick insulation
- ½" to 1¼" with 1" thick insulation
- 1½" to 2" with 1½" thick insulation

Note: When using Pre-insulated Uponor AquaPEX in direct-burial applications, Uponor recommends using a minimum 1" thick insulation due to soil compression forces.

Pre-insulated Uponor AquaPEX with ½" insulation			
Tubing size	Insulation thickness	R-value	Heat loss at 70°F Δ T
½"	0.6" (15mm)	3.9	7.4 Btu/(hr • ft)
¾"	0.6" (15mm)	3.6	9.0 Btu/(hr • ft)
1"	0.6" (15mm)	3.4	10.6 Btu/(hr • ft)
1¼"	0.6" (15mm)	3.3	12.1 Btu/(hr • ft)
1½"	0.6" (15mm)	3.2	13.6 Btu/(hr • ft)
2"	0.6" (15mm)	3.1	16.5 Btu/(hr • ft)

Table 5-11: Pre-insulated Uponor AquaPEX with ½" polyethylene insulation R-value/heat loss

Note: Pre-insulated Uponor AquaPEX consists of PEX-a pipe and closed cell, crosslinked polyethylene insulation with a thermal conductivity of 0.25 Btu•in/(hr•ft²•°F).

Pre-insulated Uponor AquaPEX with 1" insulation			
Tubing size	Insulation thickness	R-value	Heat loss at 70°F Δ T
½"	1.0" (25mm)	7.5	6.3 Btu/(hr • ft)
¾"	1.1" (28mm)	7.9	7.1 Btu/(hr • ft)
1"	1.0" (25mm)	6.4	8.8 Btu/(hr • ft)
1¼"	1.0" (25mm)	6.1	10.0 Btu/(hr • ft)

Table 5-12: Pre-insulated Uponor AquaPEX with 1" polyethylene insulation R-value/heat loss

Pre-insulated Uponor AquaPEX with 1½" insulation			
Tubing size	Insulation thickness	R-value	Heat loss at 70°F Δ T
1½"	1.7" (42mm)	11.2	7.0 Btu/(hr • ft)
2"	1.6" (40mm)	9.9	8.6 Btu/(hr • ft)

Table 5-13: Pre-insulated Uponor AquaPEX with 1½" polyethylene insulation R-value/heat loss

Uponor PEX vs. copper heat loss comparison — Btu/(hr•ft)

		Delta T (°F)	20				40				60				80				100			
		Insulation thickness (K=0.24)	0"	½"	1"	1½"	0"	½"	1"	1½"	0"	½"	1"	1½"	0"	½"	1"	1½"	0"	½"	1"	1½"
Nominal pipe sizes	½"	Uponor PEX	5.44	2.22	1.63	1.37	10.89	4.44	3.25	2.74	16.33	6.65	4.88	4.10	21.78	8.87	6.51	5.47	27.22	11.09	8.13	6.84
		Type L copper	5.76	2.24	1.63	1.37	11.52	4.47	3.27	2.74	17.27	6.71	4.90	4.11	23.03	8.95	6.53	5.48	28.79	11.18	8.16	6.85
	¾"	Uponor PEX	7.48	2.73	1.95	1.61	14.96	5.47	3.89	3.21	22.44	8.20	5.84	4.82	29.92	10.94	7.78	6.43	37.40	13.67	9.73	8.03
		Type L copper	8.06	2.77	1.96	1.61	16.12	5.54	3.91	3.22	24.18	8.31	5.87	4.84	32.25	11.07	7.83	6.45	40.31	13.84	9.78	8.06
	1"	Uponor PEX	9.42	3.23	2.25	1.83	18.85	6.47	4.50	3.66	28.27	9.70	6.75	5.49	37.69	12.93	8.99	7.33	47.11	16.17	11.24	9.16
		Type L copper	10.36	3.29	2.27	1.84	20.73	6.58	4.53	3.68	31.09	9.86	6.80	5.52	41.46	13.15	9.06	7.36	51.82	16.44	11.33	9.20
	1¼"	Uponor PEX	11.29	3.72	2.54	2.05	22.58	7.44	5.08	4.09	33.87	11.16	7.63	6.14	45.16	14.88	10.17	8.19	56.45	18.60	12.71	10.24
		Type L copper	12.67	3.80	2.57	2.06	25.34	7.60	5.14	4.12	38.00	11.40	7.70	6.18	50.67	15.20	10.27	8.24	63.34	19.00	12.84	10.30
	1½"	Uponor PEX	13.08	4.20	2.83	2.26	26.15	8.40	5.66	4.51	39.23	12.60	8.49	6.77	52.30	16.79	11.31	9.03	65.38	20.99	14.14	11.28
		Type L copper	14.97	4.31	2.86	2.27	29.94	8.61	5.73	4.55	44.91	12.92	8.59	6.82	59.89	17.23	11.45	9.10	74.86	21.53	14.32	11.37
	2"	Uponor PEX	16.46	5.13	3.39	2.66	32.93	10.27	6.77	5.33	49.39	15.40	10.16	7.99	65.85	20.54	13.55	10.65	82.31	25.67	16.94	13.32
		Type L copper	19.58	5.31	3.45	2.69	39.16	10.63	6.89	5.38	58.73	15.94	10.34	8.08	78.31	21.25	13.78	10.77	97.89	26.57	17.23	13.46
	2½"	Uponor PEX	19.30	5.92	3.92	3.00	38.60	11.85	7.84	6.01	57.90	17.77	11.76	9.01	77.20	23.69	15.68	12.01	96.50	29.61	19.60	15.01
		Type L copper	24.20	6.32	4.09	3.10	48.41	12.63	8.18	6.20	72.61	18.95	12.26	9.30	96.82	25.26	16.35	12.40	121.02	31.58	20.44	15.50
	3"	Uponor PEX	22.54	6.94	4.47	3.44	45.07	13.88	8.93	6.89	67.61	20.82	13.40	10.33	90.14	27.76	17.86	13.77	112.68	34.70	22.33	17.22
		Type L copper	28.79	7.31	4.59	3.50	57.58	14.62	9.17	7.01	86.37	21.93	13.76	10.51	115.16	29.24	18.35	14.01	143.95	36.55	22.93	17.51

Table 5-14: Uponor PEX vs. copper heat loss comparison — Btu/(hr•ft)

1. All calculations based on cylindrical thermal resistance methodology (ASPE/ASHRAE).
2. Based on fluid velocity of 8 ft./sec. at 160°F/71.1°C (maximizing heat transfer from 100% water).
3. Pipe convection set to be 1.761 Btu/hr•ft²•°F (based on standard value for free convection of air).
4. This heat loss comparison uses 0.24 Btu•in/(hr•ft²•°F) as the insulation thermal conductivity. This is a standard value for fiberglass pipe insulation at a 100°F/37.8°C mean temperature.



Uponor Ecoflex
potable PEX pipe



Uponor Ecoflex
potable HDPE pipe



Uponor Ecoflex
potable plus pipe

Uponor Ecoflex® products

Ecoflex potable PEX pipes

Ecoflex potable PEX pipes feature a single Uponor AquaPEX service pipe for potable-water distribution applications. The piping is surrounded by multi-layer, closed-cell, PEX-foam insulation and a water-resistant, corrugated, HDPE jacket, making it ideal for water service and other direct-burial applications. Ecoflex potable PEX pipes use ProPEX fittings up to 3" or WIPEX™ fittings. For more information about Ecoflex, please refer to the Ecoflex Design and Installation Manual.

Ecoflex potable PEX pipes are available in the following sizes:

- 1" in coils up to 600 ft.
- 1¼" in coils up to 500 ft.
- 1½" to 3" in coils up to 300 ft.
- Longer and custom lengths are also available

Ecoflex potable HDPE pipes

Ecoflex Potable HDPE pipes feature a single high-density polyethylene (HDPE) service pipe in ASTM sizes. This pipe is the economical solution for pre-insulated distribution for chilled-water, cooling and low-temperature heating applications. The HDPE service pipe does not have an oxygen barrier, and it is manufactured in accordance with the following standards:

- PE 3408 or PE 4710
- ASTM D3035 or F714 C3
- AWWA C901 or C906
- NSF-61 and NSF-pw

The piping is surrounded by multi-layer, closed-cell, PEX-foam insulation and water-resistant, corrugated HDPE jacket, making it ideal for direct-burial applications.

Ecoflex potable HDPE pipes can use Uponor's selection of HDPE fittings as well as standard SDR11 fittings from other manufacturers.

Ecoflex potable HDPE pipes are available in 300-foot coils in the following sizes:

- 1¼"
- 1½"
- 2"
- 3"
- 4"
- Longer and custom lengths are also available

Ecoflex potable plus pipes

Ecoflex potable plus pipes feature Uponor AquaPEX service pipe with a self-regulating heating cable. The pipe and cable are surrounded by multi-layer, closed-cell, PEX-foam insulation and a water-resistant, corrugated, HDPE jacket, making it ideal for direct-burial applications.

Ecoflex potable plus pipes are available in 1¼" pipe sizes with a 5.5" jacket or on a made-to-order basis. Contact Uponor Customer Service at 800.321.4739 (U.S.) or 888.994.7726 (Canada) for details.

Thermal expansion and contraction

All piping systems expand and contract at different rates depending on material characteristics. PEX piping systems exhibit a higher expansion and contraction rate when subjected to changes in temperature as compared to metallic piping systems. Because of its lower modulus of elasticity, PEX is less rigid than metallic piping and develops less force than metallic pipe when exposed to temperature changes.

For this reason, Uponor PEX can be easily restrained by installing PEX-a Pipe Support. With proper strapping, PEX-a Pipe Support can lessen the need for numerous directional changes and expansion loops as the pipe will absorb much of the expansion stresses. Allowing for controlled expansion and contraction in multiple parts of a piping system is an accepted means of preventing added stresses in other parts of the system that could compromise system performance, damage the structural integrity of the piping components, or damage the structure that support the piping.

Including design elements to address changes in pipe

length will redistribute the stresses that would otherwise result in uncontrolled thermal movement. According to Plastics Pipe Institute (PPI) TR-21 *Thermal Expansion and Contraction in Plastics Piping Systems*, the design and installation of a plastic piping system often requires special attention to thermal expansion and contraction.

Free-body coefficient

The free-body coefficient of expansion is a calculated, theoretical value in which all of the surfaces would be free of friction and contain no end or branch connections. The free-body coefficient of expansion for PEX-a piping is 1.1"/10°F ΔT/100 ft. (27.94mm/5.56°C ΔT/30.48m). For a given change in temperature, the theoretical expansion and contraction can be easily calculated for a given length of piping. In practice, the free-body condition for installed piping is unlikely as all surfaces would need to be free of friction.

Installation of piping in the field requires supports, strapping and bracing that inherently apply friction to the pipe surfaces, therefore, restraining pipe movement. In addition, it takes much more time for PEX-a piping to

reach temperature equilibrium due to its coefficient of thermal conductivity and wall thickness. Thermal expansion in PEX-a piping is more likely to occur in the middle temperature range than at the extremes produced by operating water temperatures. Therefore the free-body coefficient is a very conservative means of calculating pipe movements in installed conditions.

Test validation

Uponor has tested a variety of suspended PEX piping assemblies to determine which type of expansion solution works best for most applications. The results strongly support the use of PEX-a Pipe Support in conjunction with fixed anchor points positioned every 65' for hot-water and every 150' for cold-water plumbing systems. Pipe runs installed in this manner experience 89 percent to 93 percent reduction in thermal expansion. The two scenarios outlined in **Table 5-15** detail the installation of these pipe runs. The strut and strut clamps experienced the most reduction in expansion (93 percent) because of the snug grip and increased friction from pipe clamps yielding an

effective expansion rate of 0.08"/10°F ΔT/100 ft; clevis or loop type hangers offered an 89 percent reduction yielding an effective expansion rate of 0.12"/10°F ΔT/100 ft. The thermal expansion rate for copper is 0.11"/10°F ΔT/100 ft so using PEX-a Pipe Support with Uponor PEX makes the piping system perform very similarly to copper with respect to thermal expansion.

The highest force measured at fixed anchor points during these tests was 173 lbs., which is much less than the guided force of metallic piping. Properly braced fixed anchor points and commonly specified drop-in anchors, beam clamps or similar fastening components for metallic piping are of sufficient strength to support the PEX install.

Given the flexible nature of PEX pipe, a slight snaking pattern may be experienced even when PEX-a Pipe Support is utilized to control expansion. This is considered normal and does not affect the integrity of system. Pipe insulation can help to minimize the aesthetics of a slight snake in the pipe run.

Effects of thermal expansion with PEX-a Pipe Support							
Scenario	Water temperature (°F)	Delta T (°F)	Support spacing	Anchor spacing	Linear expansion	Expansion rate (inches per 100' per 10°F ΔT)	Reduction vs. bare PEX
Strut and strut clamps	180	105	96"	65'	½"	0.08	93%
Loops and clevis	175	100	96"	65'	¾"	0.12	89%

Table 5-15: Uponor PEX thermal expansion test results

Ensure the piping layout, including anchors, adequately isolates joints, fittings and connections from high-thrust or bending forces.

Uponor ProPEX connections have a very high resistance to pull-out forces when compared to other various joint types. The best solution for absorbing expansion and contraction in Uponor PEX piping systems is proper support and to build in flexibility. In applications where long piping runs may be exposed to large temperature changes, the resulting expansion and contraction must be absorbed by additional means such as expansion loops, arms and offsets or by restraining the pipe in a continuous run of PEX-a Pipe Support. Piping runs between anchors and expansion compensating devices must be periodically supported, at a spacing defined by code, with hangers or supports that allow for movement of the piping. The compensating device relieves

axial stress in a straight run of piping by transferring it into a moderate bending stress, thereby absorbing the expansion stress.

Above-ground and suspended applications

In single-family and low-rise residential applications, thermal expansion is generally not an issue due to the use of smaller-diameter piping that absorbs expansion and contraction forces due to the routing, supporting methods and flexible nature of Uponor PEX piping. Smaller diameter ($\frac{3}{8}$ " to 1") pipe runs require an extra $\frac{1}{8}$ " to $\frac{3}{16}$ " of longitudinal clearance per foot of run. Do not allow piping to dip excessively between supports and do not pull piping tight during installation.

Larger suspended commercial systems are often designed to include a number of changes in direction. These directional changes can be a beneficial aspect in the piping system by creating a spring-like effect, which safely absorbs and

controls thermal expansion and contraction.

Controlling expansion in hot-water systems

Best practice for controlling expansion forces is to continuously restrain the pipe by installing Uponor PEX-a Pipe Support. Install PEX-a Pipe Support in accordance with the installation guidelines on **pages 68-72 in Chapter 6**. For best results, terminate PEX-a Pipe Support segments only at fitting locations. Refer to **Table 6-6 on page 70** for minimum distance to fittings.

Proper use of strapping is critical when using this technique. Strapping shall be:

- Nylon-coated stainless-steel with a minimum tensile rating of 300 lbs.
- Rated for operating temperature ranges, including high temperatures
- UV-resistant to withstand expected life of the piping system

To account for expansion, use fixed anchor points to restrict piping movement. Fixed anchor points shall be:

- Installed every 65 ft. (19.8m)
- Constructed with materials that provide rigidity (see **Figure 5-6**)
- Used with a pipe clamp that will restrain piping material
- Installed within 18" of a fire-rated wall penetration (see **Figure 5-7**)

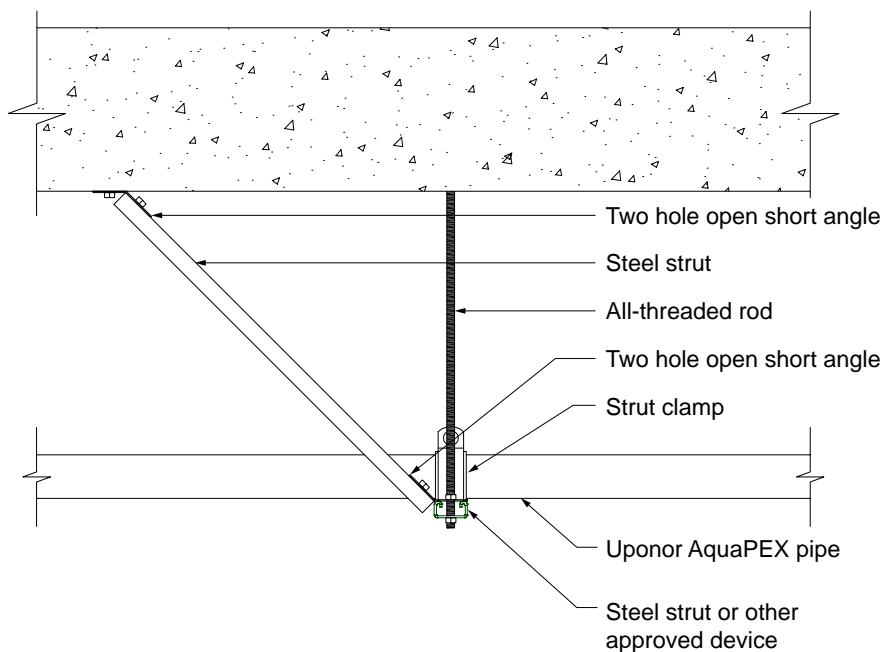

Figure 5-6: Fixed anchor point

Controlling expansion in cold-water systems

Best practice for controlling expansion forces is to continuously restrain the pipe by installing Uponor PEX-a Pipe Support. Domestic cold water systems do not typically experience the temperature differentials seen in domestic hot-water systems, therefore requiring fewer fixed anchor points. Install PEX-a Pipe Support in accordance with the installation guidelines in **Chapter 6**.

Strapping shall be:

- Nylon-coated stainless-steel with a minimum tensile rating of 300 lbs.
- Rated for operating temperature ranges
- UV-resistant to withstand expected life of the piping system

To account for expansion, use fixed anchor points to restrict piping movement. Fixed anchor points shall be:

- Installed every 150 ft. (45.7m)

- Constructed with materials that provide rigidity (see **Figure 5-6**)
- Used with a pipe clamp that will restrain piping material
- Installed within 18" of a fire-rated wall penetration (see **Figure 5-7**)

Expansion and contraction: risers

Vertical piping runs must comply with support spacing as defined by code (see **Figure 6-40 on page 80**). Best practice is to utilize the floor assembly as an anchor point

for controlling expansion and contraction by means of riser clamps. Do this by utilizing an additional riser clamp at the top of the floor assembly as listed below:

- Domestic hot water: top of every-other floor (see **Figure 6-40 on page 80**)
- Domestic cold water: top of every fourth floor

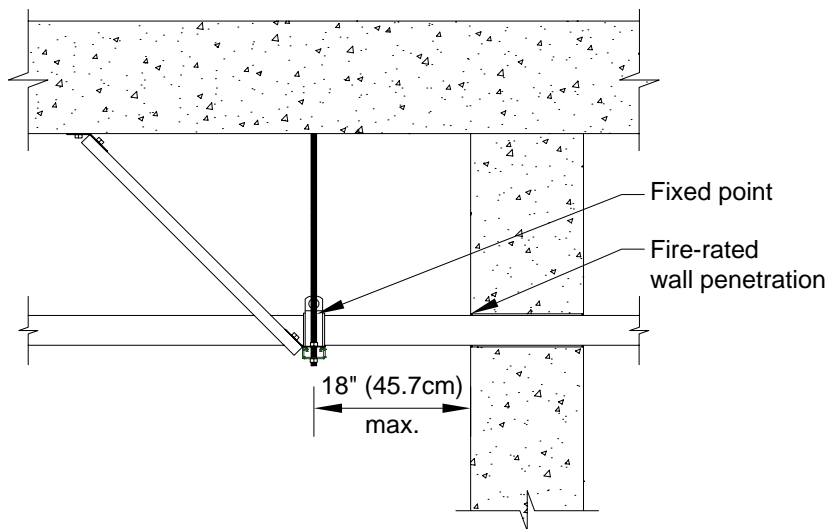

Figure 5-7: Fixed anchor point — fire-rated wall penetration

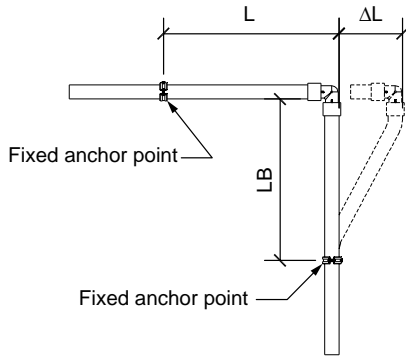

Figure 5-8: Expansion arm

Expansion arm

The flexible arm should be long enough to prevent damage, and support clamps should be placed far enough from the wall to allow for longitudinal thermal expansion (see **Figure 5-8**).

Use the formula below to calculate the minimum length of the expansion arm: $LB = C \times \text{SQRT}(D \times \Delta L)$

Where:

- L is total distance of piping run from a fixed anchor point to a corner, or in the case of an expansion loop, from a fixed anchor point to a fixed anchor point.
- LB is the flexible arm in inches.
- C is the material constant (12 for PEX).
- D is the outside diameter of the piping.
- ΔL is the thermal-expansion length in inches.

Expansion arm example:

Uponor AquaPEX piping with an outside diameter of 1.625" is installed running a length of 75 ft. The hot water it carries is 120°F/48.9°C, and the ambient temperature is 60°F/15.6°C. Calculate the length of the flexible arm. PEX piping expands at a rate of 1.1" per 10°F temperature change per 100 ft. of piping (27.94mm per

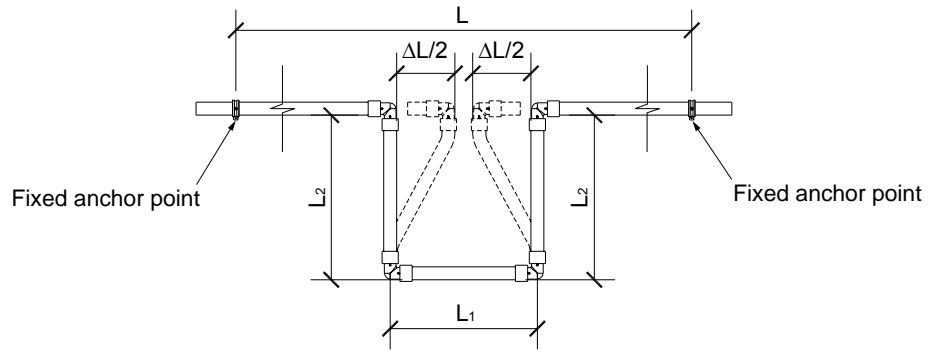

Figure 5-9: Expansion loop

5.56°C temperature change per 30.48m of piping).

$$LB = C \times \sqrt{D \times \Delta L}$$

$$LB = 12 \times \sqrt{(1.625" \times (1.1" \times (60/10)/(100 \text{ ft./ L})))}$$

$$LB = 12 \times \sqrt{(1.625" \times 4.95")}$$

$$LB = 12 \times 2.84"$$

$$LB = 34.08"$$

The required arm length (LB) is 34.08" to prevent excessive stress on the fittings and support clamps.

For a list of calculated flexible arm lengths, refer to **Appendix E**.

Expansion loop

The same equation applies for an expansion loop. However, the arm length (LB) must be divided into three sections using the following formula:

$$LB = 5L1$$

Expansion loop example:

$$5L1 = 34.08"$$

$$L1 = 34.08/5$$

$$L1 = 6.82"$$

$$L2 = 2 L1$$

$$L2 = 13.63"$$

For a list of calculated expansion loop legs, refer to **Appendix E**.

Thermal expansion in underground applications

For direct-burial applications, mitigate the effects of thermal expansion by incorporating proper installation techniques that provide adequate resistance to axial stress.

Per PPI TR-21 *Thermal Expansion and Contraction in Plastic Piping Systems*, a buried or concrete-encased pipe is effectively restrained against both lateral and axial movement by surrounding embedment material. The magnitude of the frictional restraining force is dependent on the nature of the soil and on installation and operating conditions. For example, the extent of compaction near the pipe can affect the quality of contact between the pipe and surrounding soil.

The anchoring or restraining effect of surrounding soil on pipe movement can be significantly augmented by external pipe geometry. Tees, lateral connections and changes in direction all help to anchor a pipe in the surrounding soil.

Because the friction between the pipe and surrounding material is generally sufficient to arrest axial pipe movement, a buried pipe that is subject to typical fluctuations in the

temperature of the fluid it conveys or of the soil that surrounds it is only subject to modest axial thermal stresses that are well within the strength capabilities of the pipe.

The magnitude of the soil restraint, which acts on plastic pipe with an externally smooth wall, may be estimated from the following equation:

$$f = \mu \cdot N$$

Where:

f = Axial frictional resistance (lbs./inch of pipe length)

μ = Approximate coefficient of friction between soil and pipe and between concrete and pipe. A value of 0.1 is generally accepted as a conservative representation for the case where smooth-surface plastic pipe makes full contact with the embedment material.

N = Normal soil pressure acting on 1" of width pipe (psi/inch)

$N = \pi \cdot D_o \cdot \text{Soil pressure}$, where D_o is the pipe outside diameter (inches)

An example of taking advantage of soil restraint is installing the piping in a snaking pattern and utilizing continuous runs to capitalize on the piping's flexibility.

Chapter 6:

Installation methods

This section profiles potable-water installation methods that are typical for commercial buildings to which both fire and building codes apply (generally referred to as fire-resistant construction buildings). Each method includes a detailed illustration with notes for installing potable-water piping in fire-resistant construction buildings.

For specific fire-assembly details, refer to **Chapter 3**.

Local code approvals

Before installing any piping, discuss the installation with local building and plumbing officials. While the Uponor plumbing systems described in this section meet the requirements of most building and plumbing codes found in the United States and Canada, some inspectors are not aware of these types of installations. **Chapters 1 and 3** in this design manual provide supporting information and listings for United States and Canadian code compliance.

Storing and handling PEX

Although not comprehensive, the following highlights the most common guidelines when storing and handling Uponor AquaPEX.

- Uponor AquaPEX is approved for direct connection to electric water heaters as well as power-vented gas water heaters where allowed by local code.
- Do not store Uponor AquaPEX piping outdoors.
- Keep Uponor AquaPEX piping in the original packaging until the time of installation.
- Install Uponor systems according to the installation instructions. Failure to follow the instructions and installation guidelines in this manual can result in the failure of Uponor systems.
- Do not use Uponor AquaPEX piping where temperatures and pressures exceed ratings.
- Do not use or store Uponor AquaPEX White piping where it will be exposed to direct sunlight for more than 30 days.
- Do not use or store Uponor AquaPEX Red and Blue piping where it will be exposed to direct sunlight for more than 90 days.
- Do not weld, glue or use adhesives or adhesive tape with Uponor AquaPEX piping.
Note: You may temporarily affix adhesive tape to Uponor AquaPEX piping during installation. However, to protect the integrity of the system, the tape should not be permanent. Remove the tape and residual adhesive after completing the installation.
- Do not apply open flame to Uponor AquaPEX piping.
- Minimum clearance from Insulation Contact (I.C.) rated fixtures is 2". Minimum clearance from non-I.C. rated fixtures is 12". For distances closer than the above minimums, protect the pipe with an approved insulation.
- Do not install Uponor AquaPEX within 5 ft. of direct view from fluorescent and LED lighting without protecting the pipe with a UV-blocking material.
- Do not use Uponor AquaPEX piping to convey natural gas.
- Do not solder, braze, weld or fusion-weld within 18" of any Uponor AquaPEX piping in the same water line. Make any heat-related connections prior to making the ProPEX connection.
- Do not install Uponor AquaPEX piping between the tub/shower valve and tub spout.
- Do not use Uponor AquaPEX piping for an electrical ground.
- Do not spray on or allow organic chemicals, strong acids or strong bases to come into contact with Uponor AquaPEX piping.
- Do not use petroleum or solvent-based paints, greases or sealants on Uponor AquaPEX piping.
- Use only approved and appropriate firestop materials with Uponor AquaPEX piping.
- Do not allow rodents, insects or other pests to come into contact with Uponor AquaPEX piping.
- Do not subject Uponor AquaPEX piping to blunt impact.
- Do not install Uponor AquaPEX piping in soil environments contaminated with solvents, fuels, organic compounds, pesticides or other detrimental materials

that may cause permeation, corrosion, degradation or structural failure of the piping. In areas where such conditions are suspected, perform a chemical analysis of the soil or groundwater to ascertain the acceptability of Uponor AquaPEX piping for the specific installation. Check local codes for additional requirements.

- Do not press standard ProPEX LF brass fittings (i.e., copper press). Only press Uponor ProPEX copper press adapters.
- Do not install Uponor AquaPEX pipe in steel-stud applications without the use of grommets to protect the pipe from abrasion.

Note: When transitioning from PEX to other piping materials, follow the appropriate installation instructions for that product.

Uncoiling PEX

An Uponor uncoiler is recommended for convenient uncoiling when the piping is not in the Punch&Pull™ packaging.

Bending PEX

The minimum bend radius of Uponor AquaPEX pipe is six times the outside diameter of the pipe. Use bend supports for 3/8", 1/2", 3/4" and 1" piping to facilitate 90-degree rigid bends. Use large-diameter PVC conduit to facilitate 90-degree bends in larger-diameter Uponor AquaPEX piping.

To alleviate stress on ProPEX connections and fittings, take care to not change direction immediately after a ProPEX connection. To determine whether or not the directional change is too soon, refer to the table and figures below. Uponor recommends a minimum of two times the O.D. of the pipe as the minimum distance before changing direction (see **Figure 6-1**).

Pipe size (in)	Pipe O.D. (in)	Min. bend radius (in)	2 x O.D. (in)
1/2"	0.625	3 3/4	1 1/4
3/4"	0.875	5 1/4	1 3/4
1"	1.125	6 3/4	2 1/4

Table 6-1: Minimum bend radius

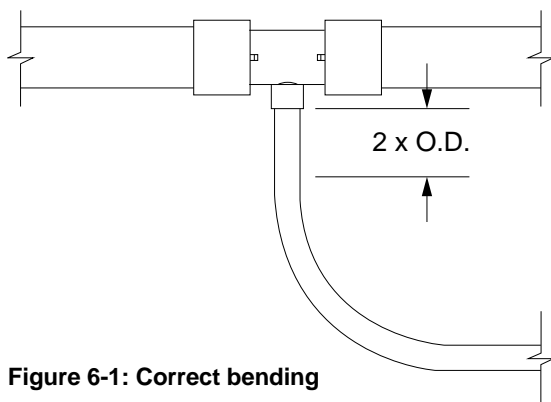

Figure 6-1: Correct bending

Note: When a proper bend cannot be achieved, use a ProPEX elbow.

Reforming kinked piping

If the piping is kinked and hinders flow, easily make repairs following the steps below.

1. Make sure the system is not pressurized.
2. Straighten the kinked portion of the piping.
3. Heat the kinked area to approximately 265°F/129.4°C with an electric heat gun (approximately 450 watts of power). Apply the heat evenly until the piping returns to its original size and shape. **Do not use an open flame** (see **Figure 6-3**).
4. Allow the repaired piping to cool undisturbed to room temperature. When the piping returns to its opaque appearance, the repair is complete.



Figure 6-3: Reforming kinked piping

Caution: The piping surface temperature must not exceed 338°F/170°C. Do not apply direct flame to Uponor AquaPEX piping. Uponor AquaPEX piping repaired according to these recommendations will return to its original shape and strength. If the piping is sliced, punctured or otherwise damaged beyond the capacity of the crosslinked memory, install a ProPEX coupling. Uponor AquaPEX piping cannot be welded or repaired with adhesives.

Thawing frozen piping

Uponor AquaPEX can withstand extreme freeze-thaw cycles better than other piping materials. In 2015, Uponor worked in partnership with standards developing organizations (SDOs) to establish a test method for performance under freeze/thaw conditions and subsequently developed a new standard for PEX piping applications. The test methodology included Uponor PEX pipe, ProPEX rings and ProPEX fitting assemblies and subjected them to repeated freeze/

thaw cycles. The assemblies were then evaluated for leaks under pressure after every cycle. Based on the samples provided and the testing performed, Uponor's 1/2" PEX pipe, ProPEX rings and ProPEX EP couplings passed the freeze/thaw cycling and subsequent burst tests without failure in accordance with the test method.

If freezing occurs, the installer should advise the end user to correct the lack of insulation or heat to eliminate the problem from reoccurring. Should Uponor AquaPEX piping experience an ice blockage, thaw the piping using one or more of the following methods.

- Pour hot water over the affected portion of piping.
- Wrap hot towels around the affected portion of piping.
- Place a small portable heating unit in the area to heat the space and thaw the ice blockage from the piping.
- Slowly heat the affected area with a hair dryer. Rub a hand over the area while heating to ensure the piping does not get too hot.

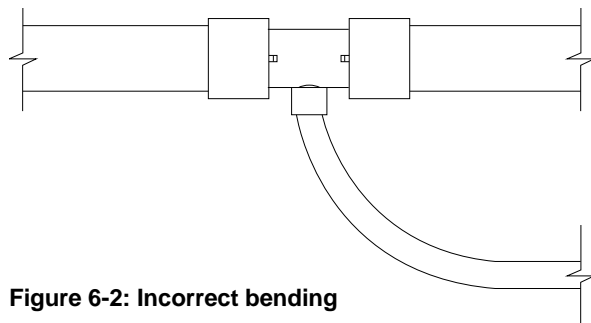

Figure 6-2: Incorrect bending

Supporting Uponor PEX pipe

Suspended runs of Uponor PEX pipe can be supported by the same conventional means as metallic pipe, using copper tube size (CTS) hangers and supports. However, support spacing will vary depending on local code requirements.

Note: Uponor recommends using hangers and supports designed for use with plastic piping.

Nominal pipe size	Spacing for bare PEX (Dimension A)			Spacing with PEX-a Pipe Support (Dimension B)		
	International codes (IPC, IMC)	Uniform codes (UPC, UMC)	National Plumbing Code of Canada (NPCC)	International codes (IPC, IMC)	Uniform codes (UPC, UMC)	National Plumbing Code of Canada (NPCC)
1/2"	32"	32"	32"	6'-0"	6'-0"	6'-0"
3/4"	32"	32"	32"	6'-0"	6'-0"	6'-0"
1"	32"	32"	32"	8'-0"	8'-0"	8'-0"
1 1/4"	32"	48"	32"	8'-0"	8'-0"	8'-0"
1 1/2"	32"	48"	32"	8'-0"	8'-0"	8'-0"
2"	32"	48"	32"	8'-0"	8'-0"	8'-0"
2 1/2"	32"	48"	32"	8'-0"	8'-0"	8'-0"
3"	32"	48"	32"	8'-0"	8'-0"	8'-0"

Table 6-2: Horizontal support spacing requirements for Uponor PEX pipe

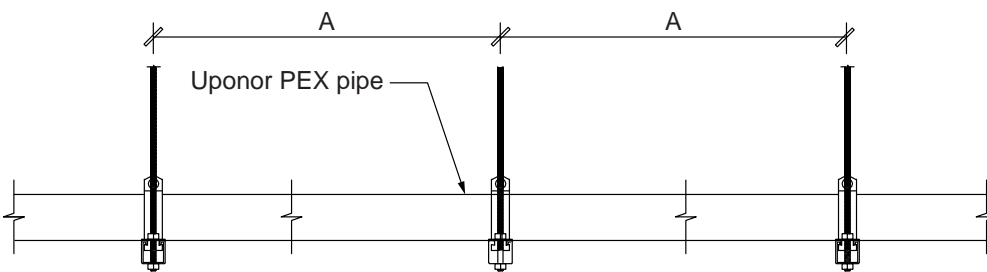

Figure 6-4: Maximum allowable support spacing for bare-PEX pipe

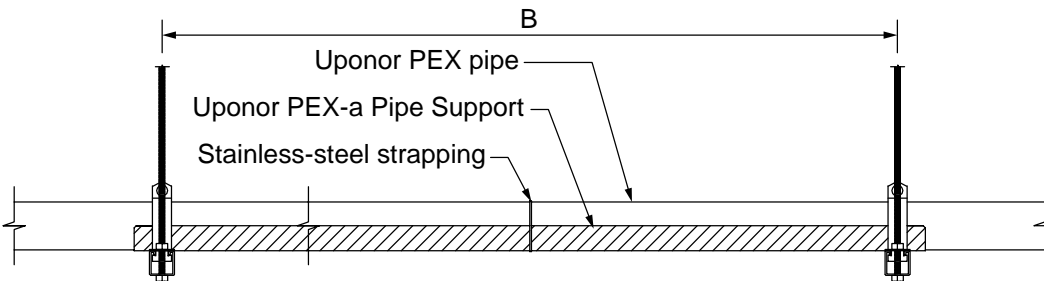

Figure 6-5: Maximum allowable support spacing for PEX pipe with PEX-a Pipe Support

Supporting fittings and valves

Sections of pipe with in-line fittings, such as tees, couplings and valves, must be supported per local code requirements.

Note: PEX-a Pipe Support cannot be used to increase hanger spacing of these pipe sections.

Nominal pipe size	Spacing for bare PEX (Dimension A)		
	International codes (IPC, IMC)	Uniform codes (UPC, UMC)	National Plumbing Code of Canada (NPCC)
1/2"	32"	32"	32"
3/4"	32"	32"	32"
1"	32"	32"	32"
1 1/4"	32"	48"	32"
1 1/2"	32"	48"	32"
2"	32"	48"	32"
2 1/2"	32"	48"	32"
3"	32"	48"	32"

Table 6-3: Support requirements for fittings

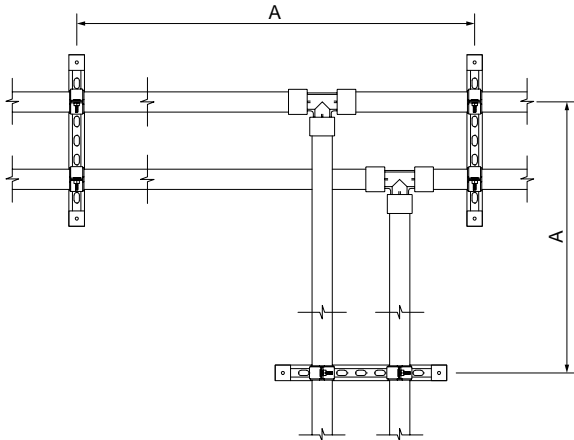

Figure 6-6: Support requirements for fittings

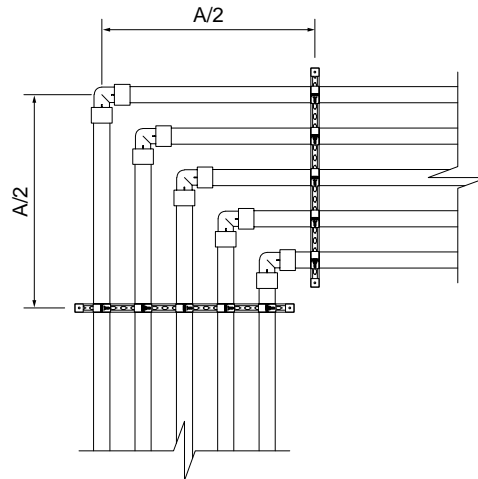

Figure 6-7: Support requirements for fittings at corners

If distance "A/2" is not attainable in **Figure 6-7**, an additional support is required as shown in **Figure 6-8**.

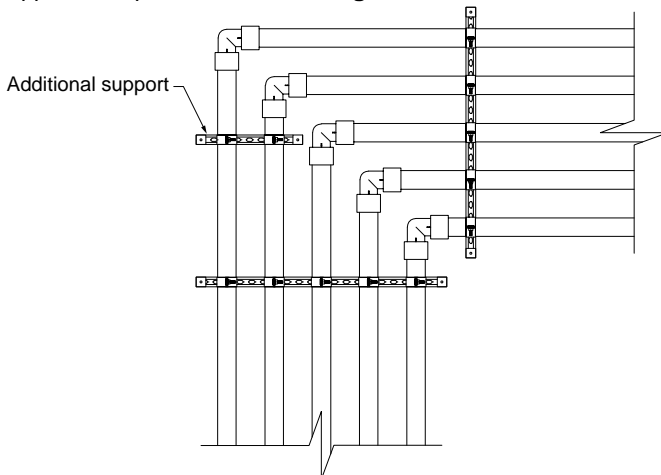

Figure 6-8: Additional support requirements for fittings at corners

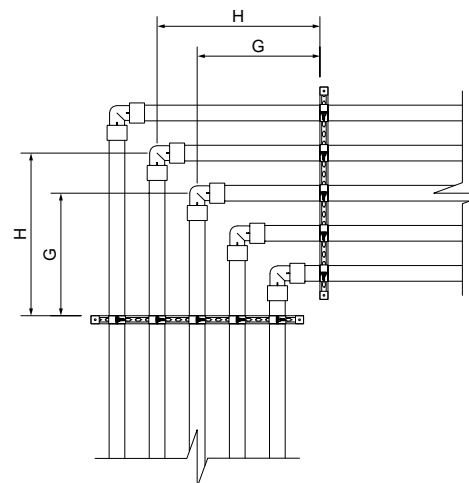

Figure 6-9: Corner support example

Distance G = 16"

Total distance for segment G = 32" (16 + 16)

Distance H = >16"

Total distance for segment H = >32"

Nominal pipe size	Spacing for bare PEX (Dimension A)			Dimension B
	International codes (IPC, IMC)	Uniform codes (UPC, UMC)	National Plumbing Code of Canada (NPCC)	All codes
1/2"	32"	32"	32"	- ¹
3/4"	32"	32"	32"	- ¹
1"	32"	32"	32"	- ¹
1 1/4"	32"	48"	32"	18" ²
1 1/2"	32"	48"	32"	18" ²
2"	32"	48"	32"	18" ²
2 1/2"	32"	48"	32"	7" ³
3"	32"	48"	32"	7" ³

Table 6-4: Support requirements for valves

¹Place 1/2" to 1" ball valves anywhere within Dimension A.

²Based on a ProPEX ball valve or similar

³Based on ductile-iron butterfly valves or similar

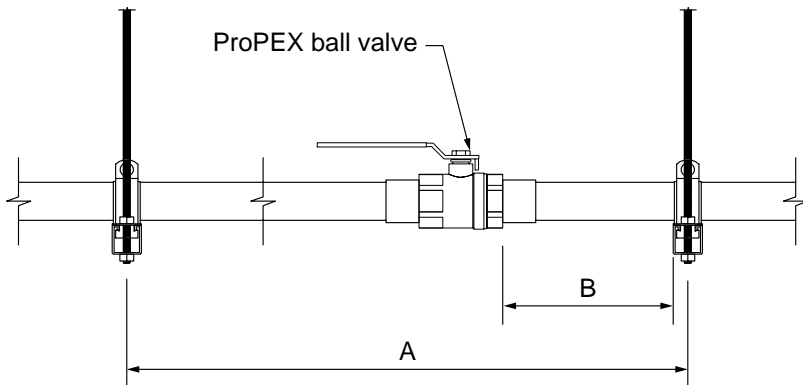

Figure 6-10: Supporting 1 1/4" to 2" ball valves

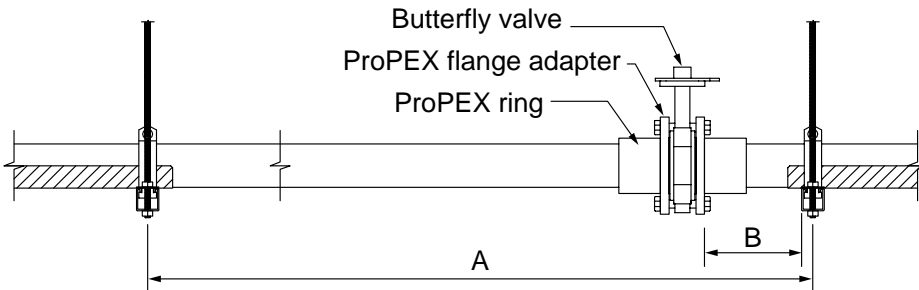

Figure 6-11: Supporting 2 1/2" to 3" butterfly valves

When distance "B" in the above example is not attainable, additional support of the valve is required as shown in **Figure 6-12**.

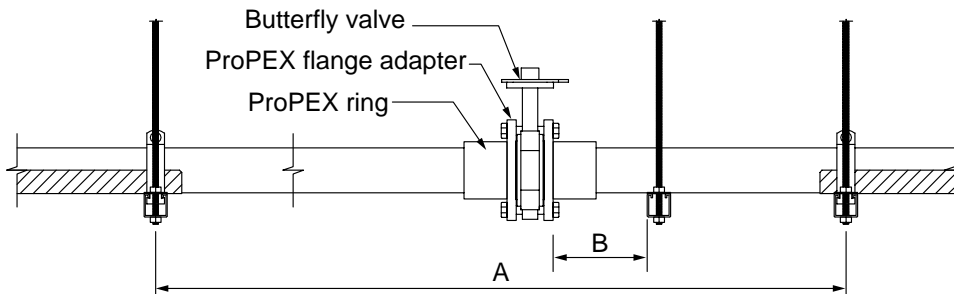

Figure 6-12: Additional support for butterfly valves

Uponor PEX-a Pipe Support

PEX-a Pipe Support is a 23-gauge galvanized-steel channel for PEX piping with a CTS (copper tube size) controlled outside diameter. It features a profile that is over half-round, making it self-gripping. It provides continuous, uninterrupted support of PEX piping, allowing increased hanger spacing over bare PEX.

Product offering

PEX-a Pipe Support is available in 9-foot (3m) lengths in the following sizes:

- ½"
- ¾"
- 1"
- 1¼"
- 1½"
- 2"
- 2½"
- 3"
- 3½"

Nylon-coated stainless-steel straps

Each bundle of PEX-a Pipe Support includes a package of stainless-steel straps. The straps carry a 300-lb. tensile rating and are tested for the appropriate applications.

Insulating PEX-a Pipe Support

The low profile of PEX-a Pipe Support allows insulation with typical CTS pipe insulation.

Important tips for installing PEX-a Pipe Support

- Always follow local code for general piping support requirements.
- All pieces of PEX-a Pipe Support must have a minimum of two supports/hangers.
- Use the included 300-lb., tensile-rated, stainless-steel straps to secure the support channel to the pipe. If the included straps are misplaced, use a stainless-steel strap of equal or greater strength.
- Due to expansion characteristics of Uponor PEX piping, it is important to use a minimum 300-lb., stainless-steel cable tie or equivalent for securing the PEX-a Pipe Support to the piping.

Tips for cutting PEX-a Pipe Support

- Always cut the PEX-a Pipe Support starting from the round side.
- When using a reciprocating or band saw to cut the PEX-a Pipe Support, either place the support flat-side down to make a clean cut or place a scrap piece of pipe into the support before cutting.
- When using a hand tool such as tin snips to cut the PEX-a Pipe Support, place the support flat-side down and mark a line on the support to follow.
- When cutting a support, take care not to bend it.
- After cutting PEX-a Pipe Support, taper and smooth any sharp edges.

Hanger and support layouts with PEX-a Pipe Support

In general, the use of Uponor PEX-a Pipe Support will allow for increased hanger and support spacing over bare PEX pipe. However, because PEX-a Pipe Support is a secondary-support material that is added to the outside of the pipe, the introduction of fittings or joints will interrupt the use of the pipe support, resulting in staggered hanger spacing scenarios (see **page 69** for examples).

Designing hanger and support layouts

Uponor recommends detailed hanger and support layouts utilizing the methods outlined on **pages 69** and **70**.

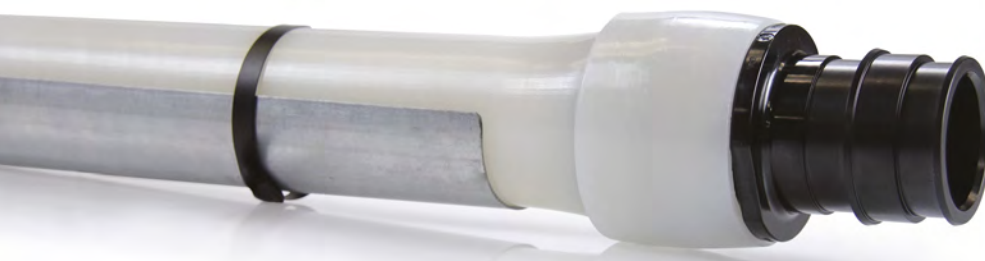

Figure 6-13: Uponor PEX-a Pipe Support with nylon-coated, stainless-steel strapping

General requirements for PEX-a Pipe Support

- PEX-a Pipe Support can be used to achieve greater spans than those shown in Dimension A in the table below.
- Segments of PEX-a Pipe Support that are greater than the distances in Dimension A in the table below require a minimum of two supports.

Nominal pipe size	Spacing for bare PEX (Dimension A)			Spacing with PEX-a Pipe Support (Dimension B)		
	International codes (IPC, IMC)	Uniform codes (UPC, UMC)	National Plumbing Code of Canada (NPCC)	International codes (IPC, IMC)	Uniform codes (UPC, UMC)	National Plumbing Code of Canada (NPCC)
1/2"	32"	32"	32"	6'-0"	6'-0"	6'-0"
3/4"	32"	32"	32"	6'-0"	6'-0"	6'-0"
1"	32"	32"	32"	8'-0"	8'-0"	8'-0"
1 1/4"	32"	48"	32"	8'-0"	8'-0"	8'-0"
1 1/2"	32"	48"	32"	8'-0"	8'-0"	8'-0"
2"	32"	48"	32"	8'-0"	8'-0"	8'-0"
2 1/2"	32"	48"	32"	8'-0"	8'-0"	8'-0"
3"	32"	48"	32"	8'-0"	8'-0"	8'-0"

Table 6-5: Maximum allowable support spacing for PEX pipe

Scenario 1: No fittings

The following scenario involves Uponor PEX pipe from a coil with PEX-a Pipe Support and no fittings.

- Maximum hanger spacing is 6' to 8' for all pipe segments (per Dimension B in above table).

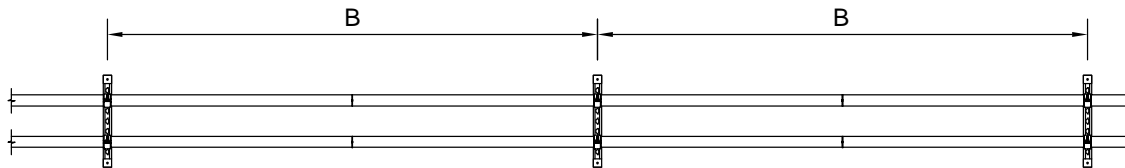

Figure 6-14: PEX-a Pipe Support without fittings

Scenario 2: Segments with fittings

The following scenario features Uponor PEX pipe with PEX-a Pipe Support and fittings.

- Maximum hanger spacing is 6' to 8' for full-length pipe segments with PEX-a Pipe Support (per Dimension B in above table).
- Hanger spacing changes to Dimension A for fitting segment (spacing for area with no PEX-a Pipe Support).

Note: Uponor recommends detailed hanger and support layouts using the above methods for PEX pipe.

Note: Simply placing hangers at a consistent on-center distance (e.g., 6'-0", 6'-0"...) will not provide the full-benefits of PEX-a Pipe Support when using fittings.

- Using the recommended installation methods will allow for the maximum benefit of PEX-a Pipe Support because the designer is able to stagger hanger locations based on the PEX-a Pipe Support lengths.

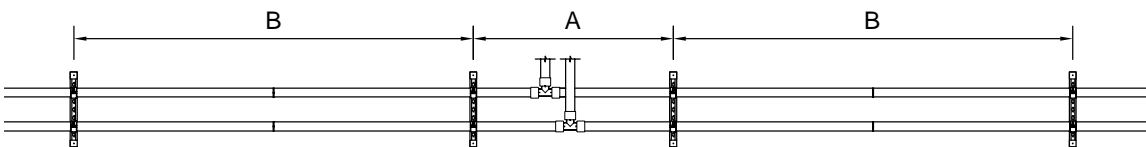

Figure 6-15: PEX-a Pipe Support with fittings

Nominal pipe size	Max. support spacing (A)	Max. cantilever (B)	Min. overlap (C)	Min. distance to fitting (D)	Min. overhang (E)
1/2"	6'-0"	18"	6"	1 1/4"	1"
3/4"				1 3/4"	
1"	2 1/4"				
1 1/4"	2 3/4"				
1 1/2"	3"				
2"	4"				
2 1/2"	5"				
3"	6"				

Table 6-6: Uponor PEX-a Pipe Support minimum and maximum spacing requirements

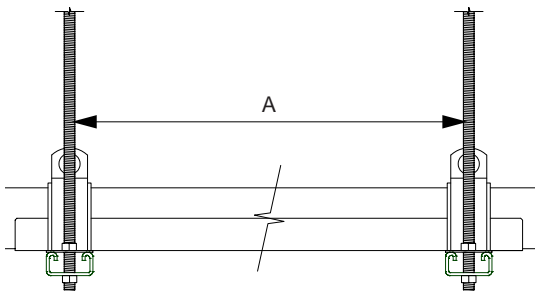

Figure 6-16: Maximum support spacing

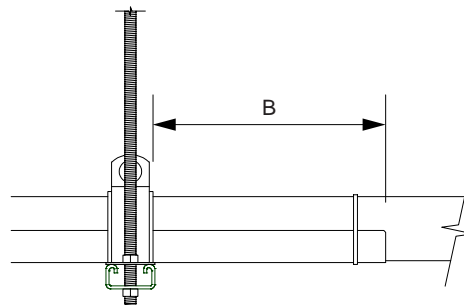

Figure 6-17: Maximum cantilever

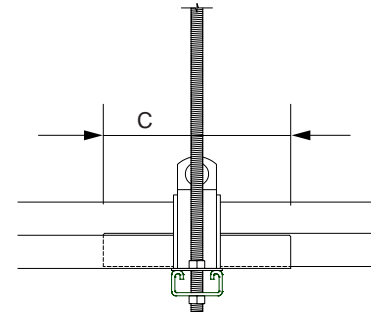

Figure 6-18: Minimum overlap

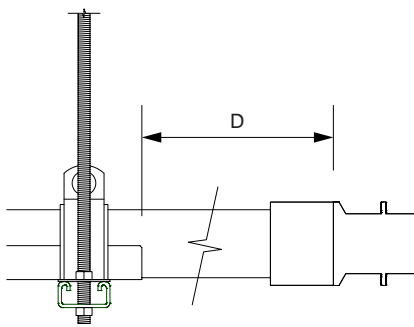

Figure 6-19: Minimum distance to fitting

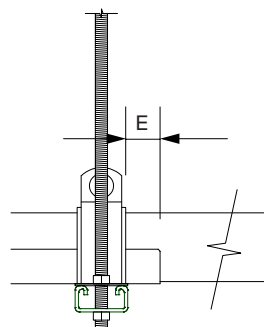

Figure 6-20: Minimum overhang

Strapping requirements for PEX-a Pipe Support

Uponor requires PEX-a Pipe Support be strapped with a minimum 300-lb., tensile-rated, stainless-steel strap that is suitable for the application (i.e., UV, high temperature).

Note: Uponor includes required stainless-steel straps with the PEX-a Pipe Support. If the included straps are misplaced, use a stainless-steel strap of equal or greater strength.

Application	Maximum distance
Clamps	Greater than 48" = 1 strap mid-span
Hangers	<ul style="list-style-type: none"> • Less than 48" = 2 straps equally spaced • Greater than 48" = 3 straps (1 mid-span and 1 on each end placed 2" from end of support)

Table 6-7: Strapping requirements for clamps and hangers

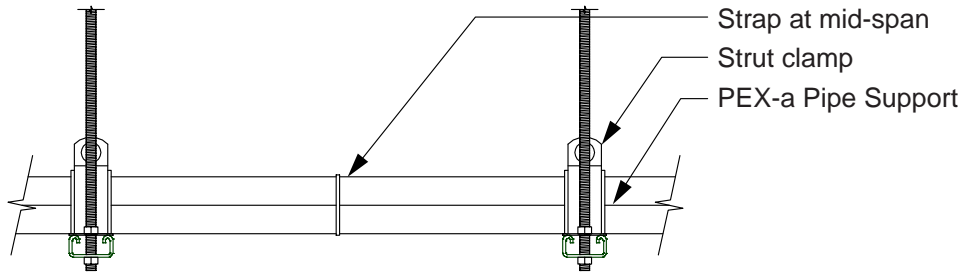

Figure 6-21: Strapping for systems using strut-type clamps or equivalent

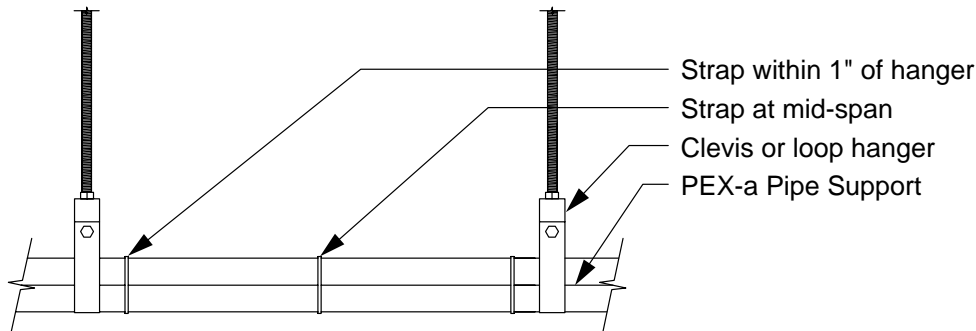

Figure 6-22: Strapping for systems using clevis or loop-type hangers or equivalent

Expansion and contraction control with PEX-a Pipe Support

When properly installed, Uponor PEX-a Pipe Support can reduce linear expansion and contraction by up to 93 percent when compared to bare-PEX pipe. For more information, refer to **Table 5-15** on **Page 59**.

Refer to the following requirements.

- 300-lb., tensile-rated, stainless-steel straps (included)
- Fixed anchor points installed every 65 ft. for domestic hot-water applications ($\Delta T > 40^\circ\text{F}$)
- Fixed anchor points installed every 150 ft. for domestic cold-water applications ($\Delta T > 40^\circ\text{F}$)

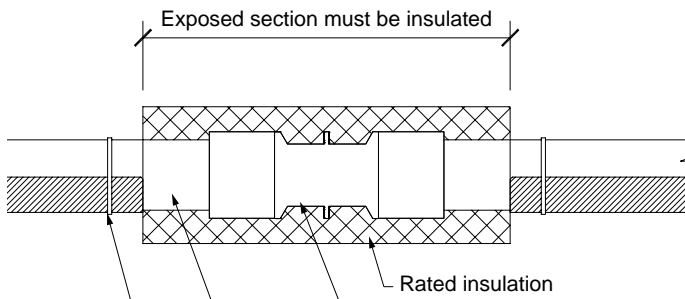

Figure 6-23: PEX-a Pipe Support installations in ASTM E84 applications

ASTM E84 requirements for PEX-a Pipe Support

Uponor PEX-a Pipe Support has been tested and approved for use in ASTM E84 applications. To meet the requirements, PEX-a Pipe Support must be installed per the following requirements:

- Pipe or fittings without PEX-a Pipe Support shall be covered with a minimum $\frac{1}{2}$ " thick insulation.
- There is no minimum segment length of PEX-a Pipe Support.

When installed per the above requirements, there are no spacing limitations between parallel piping runs.

Note: The above requirements also apply to PEX-a Pipe Support installed in a vertical position for ASTM E84 applications.

Note: Exposed sections of $\frac{1}{2}$ " and $\frac{3}{4}$ " Uponor PEX pipe can be installed un-insulated if the pipe runs are separated by a minimum of 18".



Figure 6-24: Uponor PEX-a Pipe Support with nylon-coated, stainless-steel strapping

Supporting Uponor multiport tees

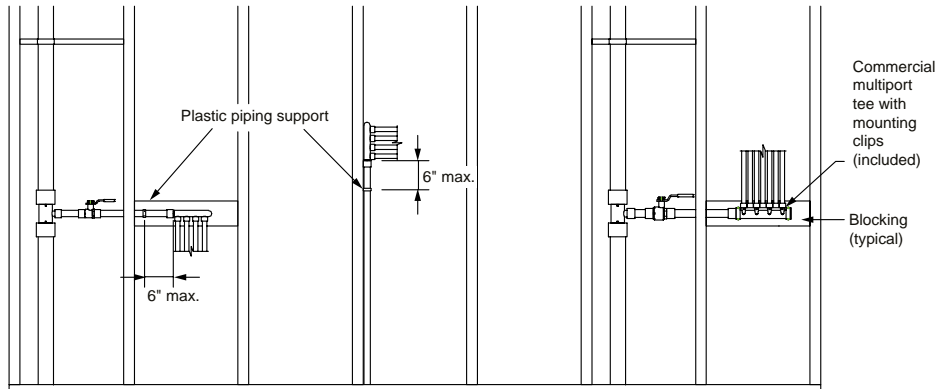

Figure 6-25: In-wall supports for multiport tees

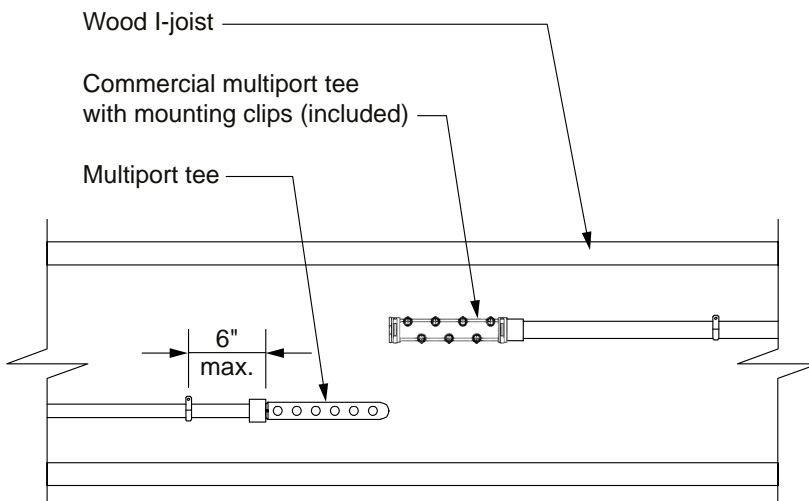

Figure 6-26: Supporting multiport tees on wood I-joists

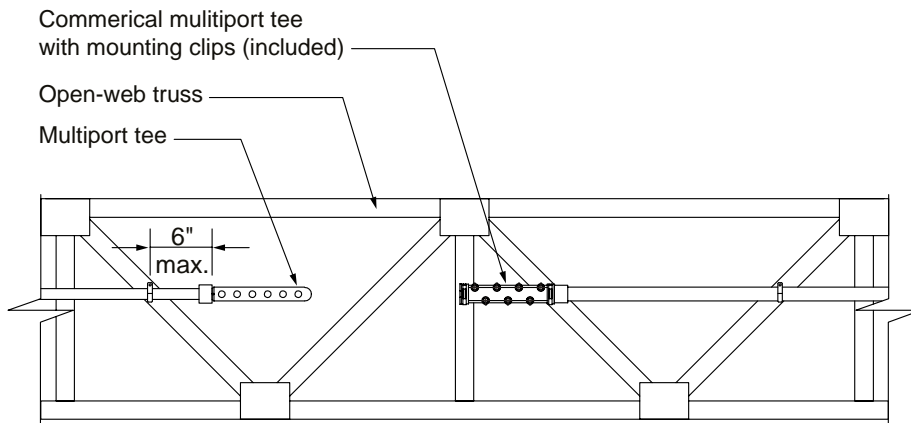

Figure 6-27: Supporting multiport tees on open-web wood trusses

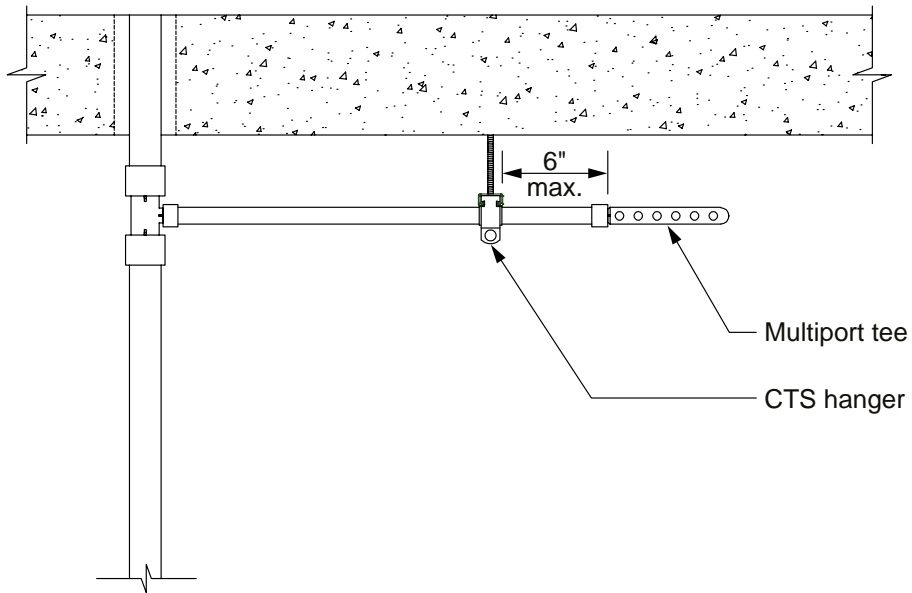

Figure 6-28: Supporting multiport tees in suspended applications

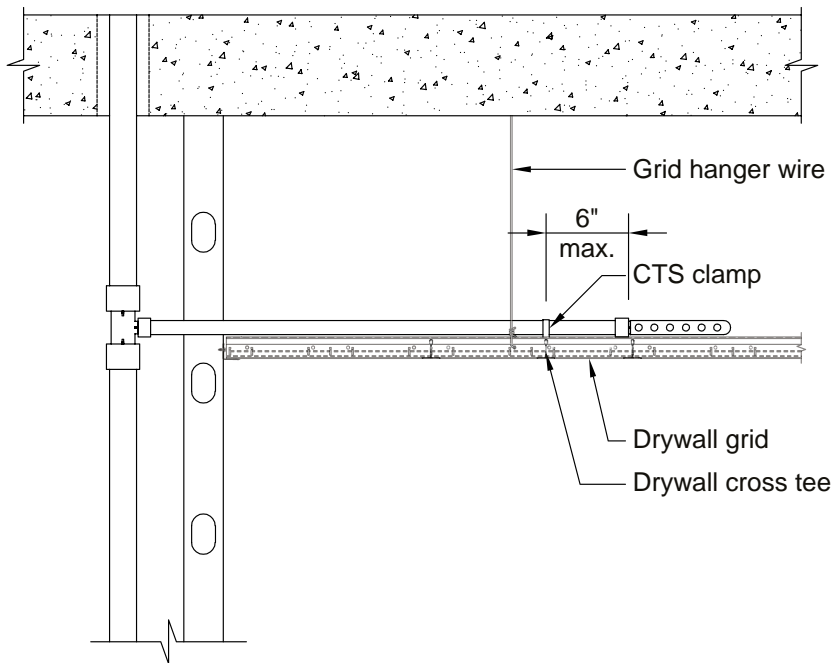

Figure 6-29: Supporting multiport tees on drywall grid

Vertical support requirements

Vertical runs of pipe fall into two categories: in wall and risers.

In-wall piping is typically smaller in diameter (<1"), and does not pass through multiple stories like a riser. It is most often the dedicated supply piping to the fixture.

Riser piping is typically larger in diameter (>1") and passes through multiple stories, often requiring fire-penetration sealants.

Note: The two categories above are not mutually exclusive. Use best judgment when determining which supports are necessary.

		Nominal pipe size	All codes
Vertical	In wall	All pipe sizes	5 ft. (1.5 m)
	Risers	Domestic cold water	Clamp at base of each floor; clamp at top of every fourth floor; provide mid-story guide
		Domestic hot water	Clamp at base of each floor; clamp at the top of every-other floor; provide mid-story guide
		Heating hot water, chilled water	Clamp at the base of each floor; clamp at the top of every floor; provide mid-story guide

Table 6-8: Vertical support requirements for PEX pipe

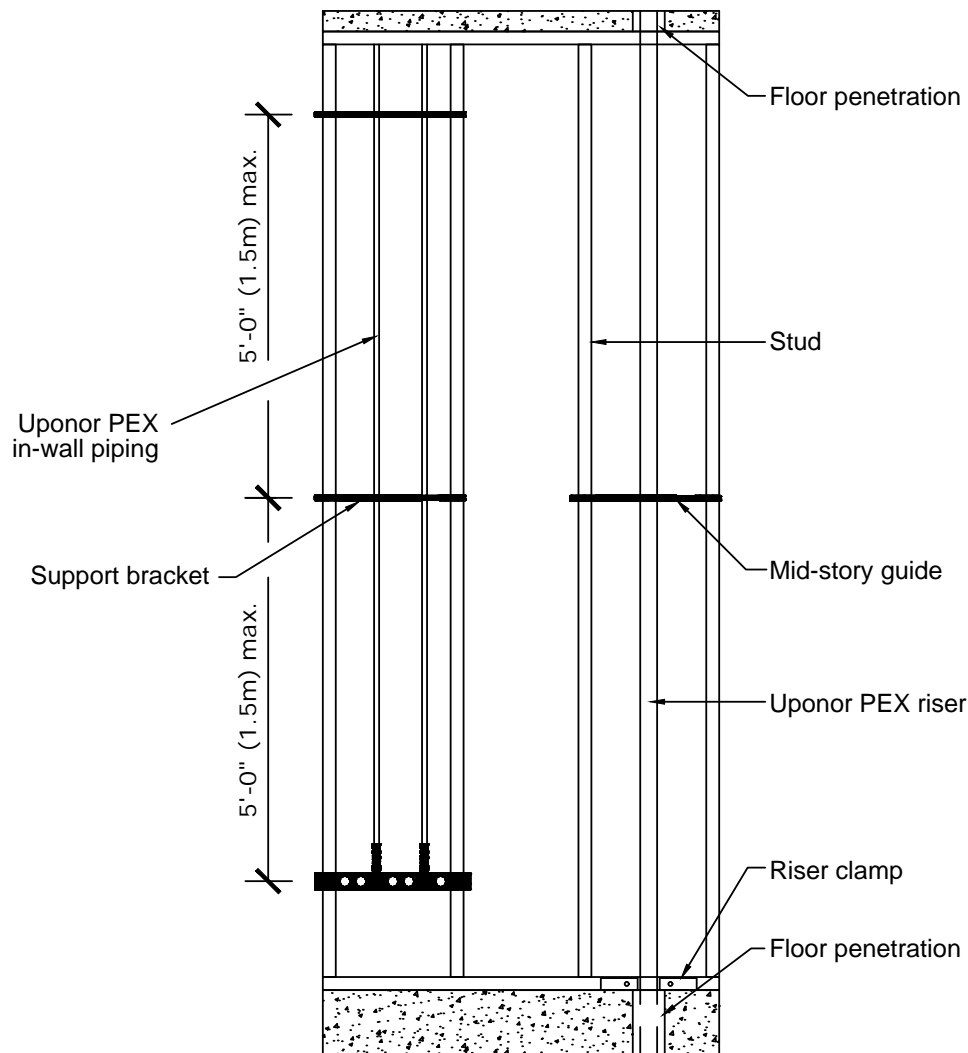

Figure 6-30: In-wall versus riser piping

Support methods

The following pages provide examples of PEX installations in various commercial building applications. While not every method is included, the following examples address the majority of installations in North America. Other installation methods are available; contact Uponor for further guidance in these situations.

Wood-frame construction

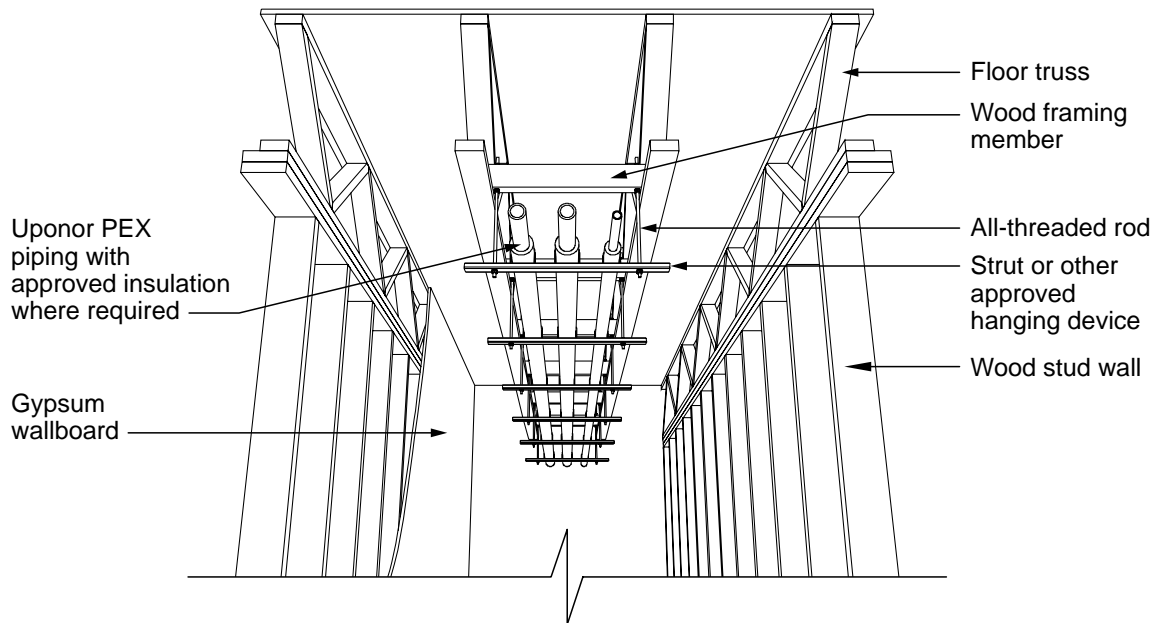

Figure 6-31: Hallway/corridor detail

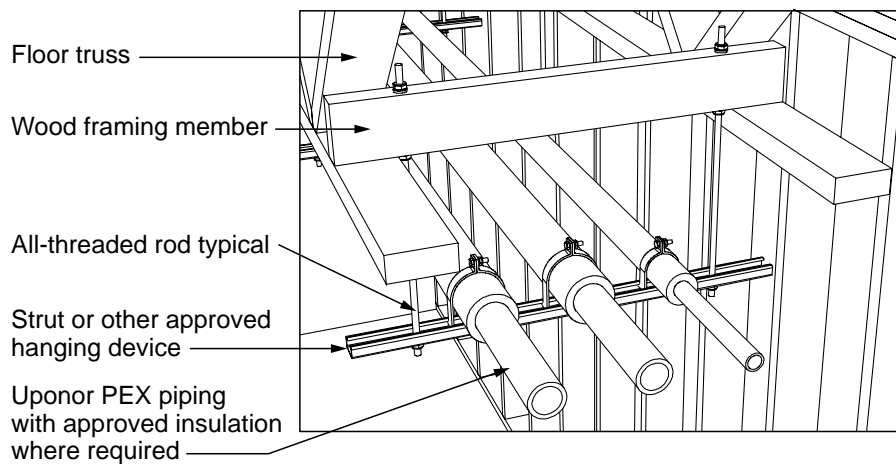

Figure 6-32: Hanger detail

Steel-frame construction

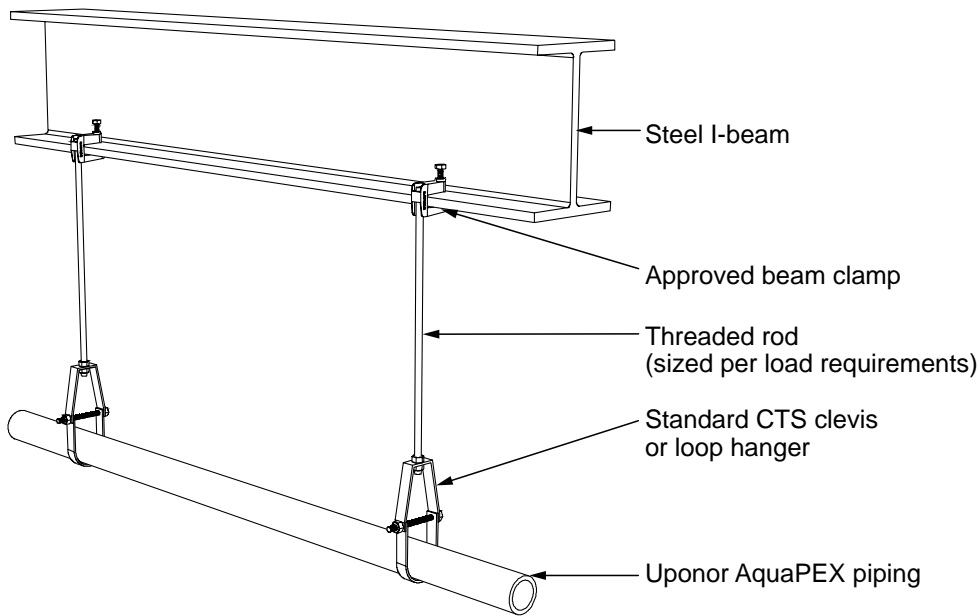

Figure 6-33: Steel beam with standard CTS clevis hangers

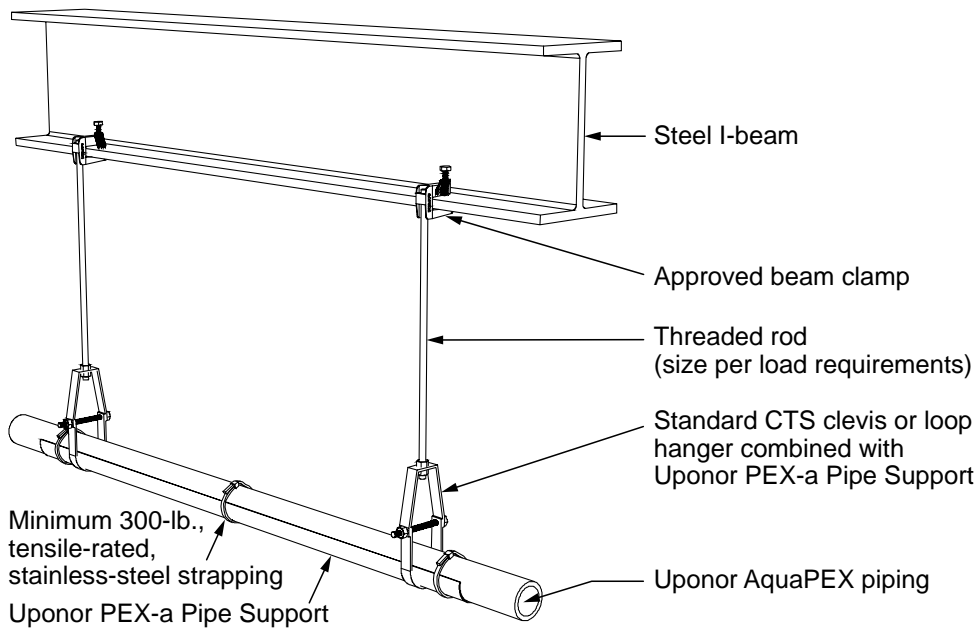

Figure 6-34: Steel beam with standard CTS clevis hangers and Uponor PEX-a Pipe Support

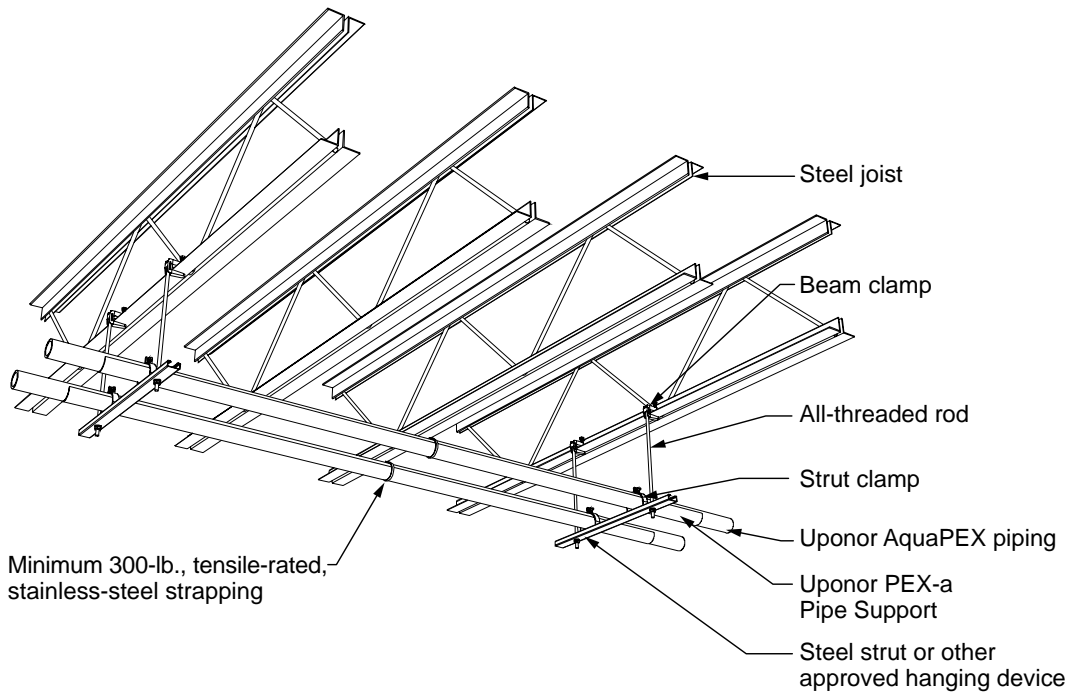

Figure 6-35: Uponor PEX suspended from steel joists with strut and Uponor PEX-a Pipe Support

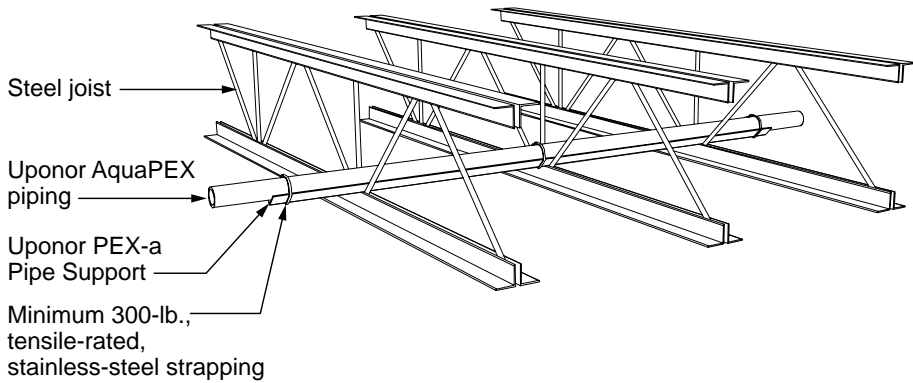

Figure 6-36: Uponor PEX supported by steel joists and PEX-a Pipe Support

Expansion-compensating devices

As a generally accepted practice, an expansion-controlling device with fixed anchor points or a continuous run of PEX-a Pipe Support with fixed anchor points is installed every 65 ft. of straight-length piping in a domestic hot-water system. Always install the device at the mid-point of two fixed points (see **Figure 6-37**).

Fixed anchor points

To account for expansion, use fixed anchor points to restrict piping movement. Ensure fixed anchor points are constructed with materials that will provide rigidity to the support system and use a pipe clamp that will restrain the specific piping material.

When installing strut-type applications, Uponor recommends using rubber-lined strut clamps to aid in the restriction of movement.

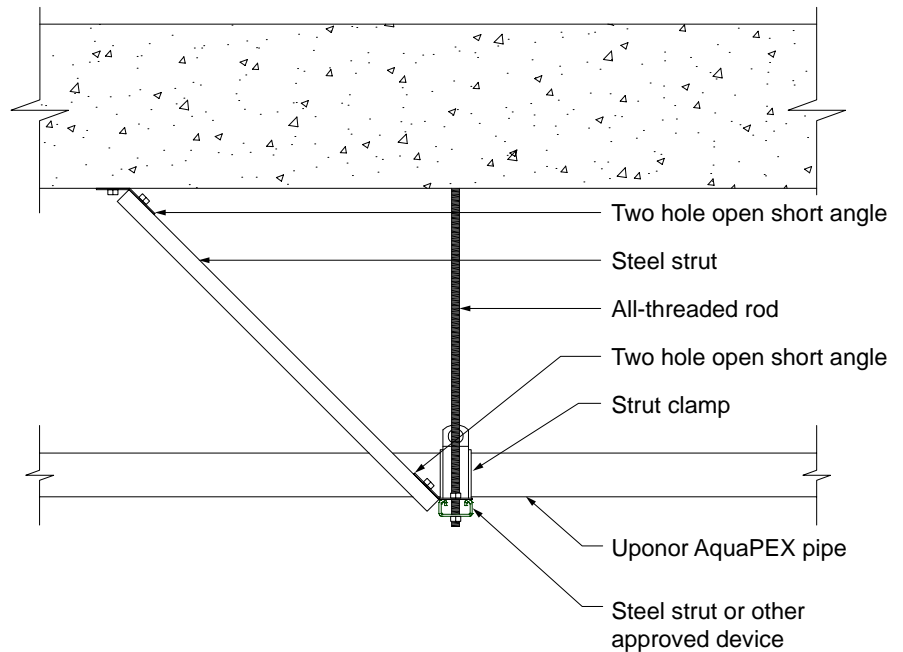

Figure 6-37: Fixed anchor point

Expansion arm

The flexible arm should be long enough to prevent damage; place support clamps far enough from the wall to allow for longitudinal thermal expansion.

For a list of calculated flexible arm lengths, refer to **Appendix E**.

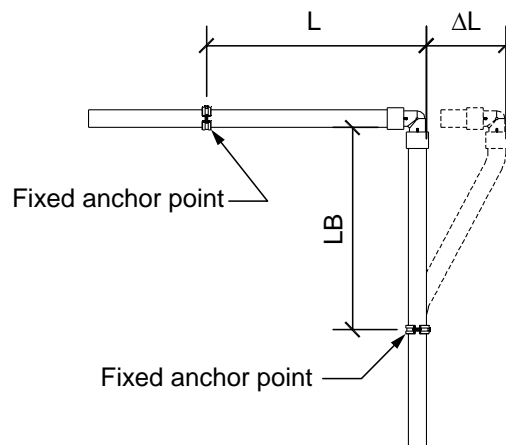

Figure 6-38: Expansion arm

Expansion loop

The same applies for an expansion loop. However, the arm length (LB) must be divided into three sections.

For a list of calculated expansion loop legs, refer to **Appendix E**.

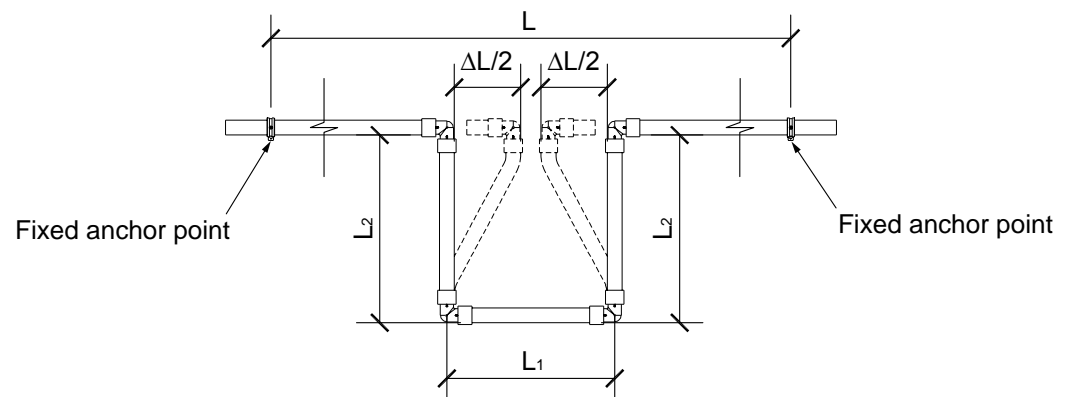
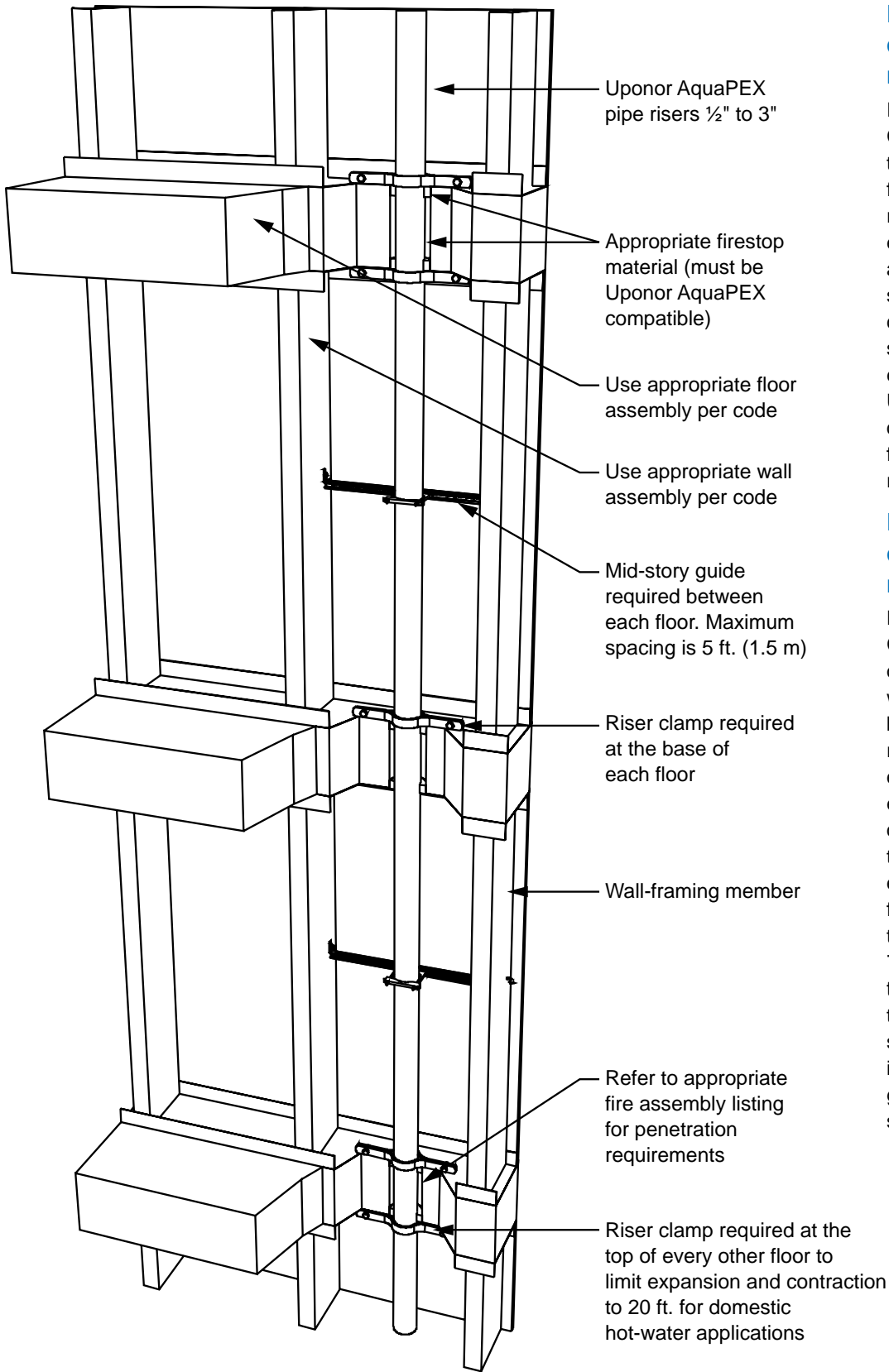

Figure 6-39: Expansion loop



Expansion and contraction: cold-water risers

In cold-water applications, use CTS riser clamps to support the piping at the base of each floor. In conjunction with the riser clamps at the base of each story, use a riser clamp at the top of every fourth story, limiting expansion and contraction to 40 feet. A mid-story guide is also required on every story to guide the piping. Uponor recommends the use of iron pipe size (IPS) clamps for mid-story guides as to not restrain the piping.

Expansion and contraction: hot-water risers

For hot-water applications, use CTS riser clamps at the base of each story. In conjunction with the riser clamps at the base of each story, use a riser clamp at the top of every-other story, limiting the expansion and contraction of the piping to 20 ft. This translates to a theoretical expansion of about 1½" in 20 ft. of piping at a 70°F/38.9°C temperature rise (installed at 70°F/21.1°C and a service temperature of 140°F/60°C). In this application, the piping will snake slightly in areas where it is not constrained. A mid-story guide is also required on every story to guide the piping.

Figure 6-40: Hot-water risers

Public-use fixtures

Water hammer is probably the most significant concern when piping for public-use fixtures.

In typical installations with metallic piping where back-to-back restrooms are separated by a mechanical chase, the supply header is usually kept at roughly the same height as the fixture supply. This creates sharp, abrupt paths for the water, resulting in pressure surges (water hammer) when a fast-actuating valve closes. To compensate, most local codes require water hammer arrestors.

The flexibility of Uponor AquaPEX piping combined with its ability to withstand high surge pressures makes it the perfect product for supplying public-use fixtures. PEX has an approximate modulus of elasticity of 91,350 psi, compared to

copper's 16,000,000 psi. Refer to **Chapter 5** for more information about expansion and contraction.

Because Uponor requires a minimum distance between ProPEX fittings (see **Table 2-1**), take care when creating a fixture header. In typical installations using Uponor AquaPEX, the PEX header is elevated to allow for adequate spacing between ProPEX tees and to also offer ample room for AquaPEX pipe drops to the fixture (see **Figure 6-42**).

Pipe labels

If pipe labels are required to be affixed to Uponor AquaPEX pipe, Uponor approves the use of permanent, flexible, vinyl stickers with pressure-sensitive acrylic. Consult local code for proper placement and requirements regarding pipe labeling.

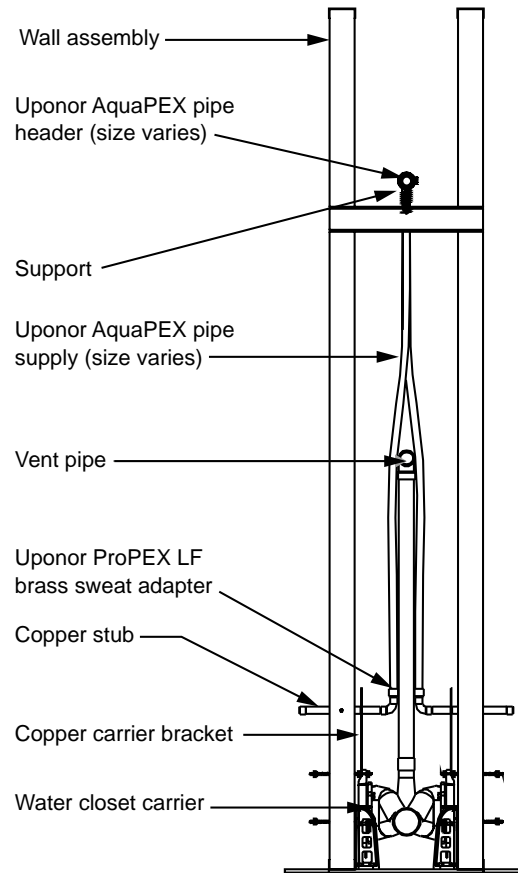

Figure 6-41: Fixture bank section view

Commercial flush bank detail

Water hammer arrestor where required by code (exact locations vary by manufacturer)

Bend support (½" to ¾" typical)

Uponor AquaPEX pipe supply (size varies)

Stud wall assembly

Uponor AquaPEX pipe header (size varies)

Uponor ProPEX EP tee

Isolation ball valve (typical)

Support

Vent pipe

Waste pipe

Copper stub

Urinal carrier behind

Copper carrier bracket

Water closet carrier

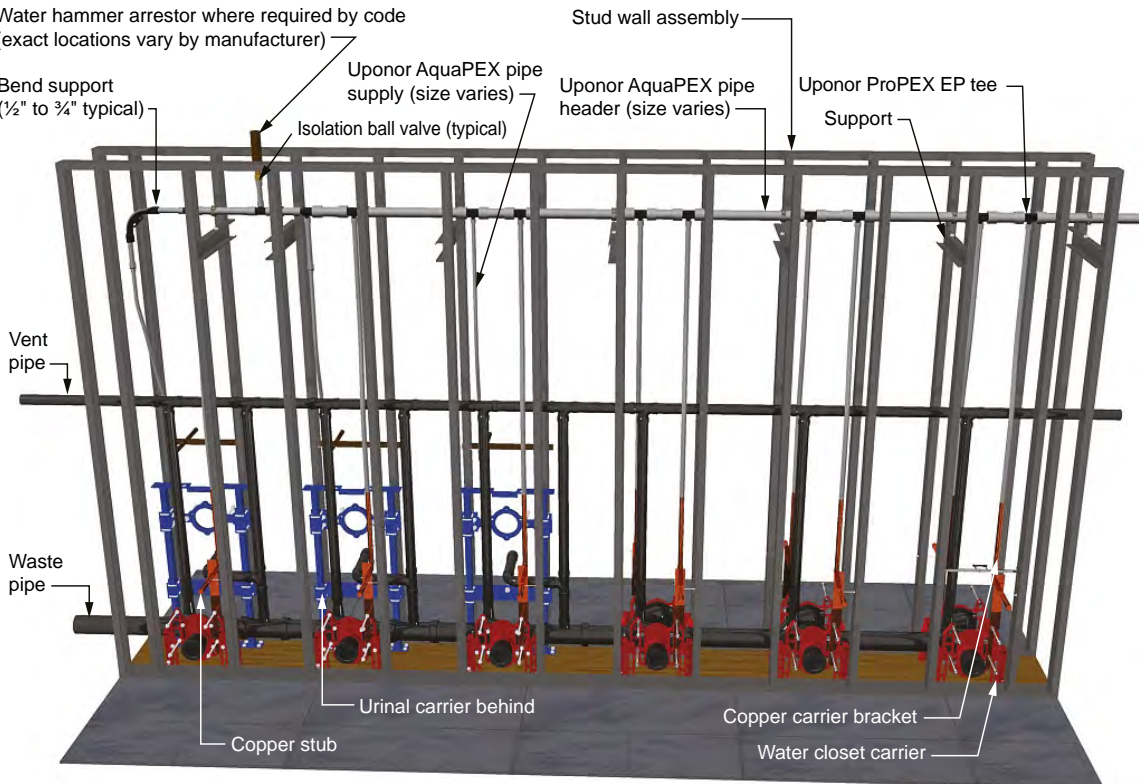

Figure 6-42: Fixture bank elevation view

Below-grade and in-slab installation

Alternative methods to overhead piping include below-grade and in-slab piping. In these installations, the pipe is laid in a trench or secured to steel-reinforcing bar (rebar) or wire mesh and routed to the desired locations. The piping system is pressurized (usually 20 psi above working pressure) and buried. Because PEX piping is available in long, continuous lengths, it is an ideal material for running below grade or in-slab without fittings. (See **page 84** for proper trench preparation.) Always follow local code when burying Uponor PEX pipe as some jurisdictions require additional sleeving and protection.

Fittings for below-grade and in-slab

Uponor EP and LF brass fittings are all approved for use in below-grade and in-slab applications. Uponor recommends EP fittings for in-slab applications where required.

Uponor's LF brass is approved for direct burial in soil per NSF/ANSI Standard 14 testing which established minimum performance criteria for dezincification resistance (DZR) and stress-corrosion cracking (SCC) resistance for PEX fittings intended for potable water.

Termiticides and pesticides

Uponor AquaPEX piping for hot- and cold-water distribution is approved for installation directly in soil (below-grade) or in concrete (in-slab) where soil termiticide/pesticide treatment is required. This is especially useful in slab-on-grade

construction. See **page 88** for information about termiticides.

Pre-insulated Uponor AquaPEX piping

Pre-insulated Uponor AquaPEX piping is approved for use in below-grade and in-slab applications. For below-grade applications, Uponor recommends the use of pre-insulated AquaPEX with a minimum 1"-thick insulation due to static soil loads.

Protect piping where it enters and exits a concrete slab with 0.025" (0.064mm) thick protective material, such as HDPE wrapping, closed-cell pipe insulation, PVC elbows and sleeves or equivalent, that allow expansion and contraction of the piping. Ensure proper placement where piping exits the slab. These products are described as slab-penetration protection devices.

Pre-sleeved Uponor AquaPEX piping

When using pre-sleeved Uponor AquaPEX piping or a protection sleeve, an annular gap between these protection devices and the PEX piping will exist. In such installations, fill the annular gap between the protection device and the PEX piping at the exposed ends to help prevent pathways for pests and the mistaken application of harmful chemicals into the space between the PEX piping and the protection device. Use only sealants that are compatible with PEX piping.

Note: The following products are appropriate for use when sealing PEX piping and slab-penetration protection devices:

- Latex caulk
- Latex foam
- Silicone sealant
- Polyurethane expanding foam

Note: Misapplication of these products could result in pooling or puddling of the products around the PEX piping, which is prohibited.

Caution:

- If applying termiticides/pesticides while the installed PEX piping still has exposed open ends that are not yet connected to plumbing fixtures, cap, plug or close the ends of the piping to prevent these chemicals from entering the piping.
- Do not allow organic (petroleum-based) chemicals, petroleum distillates, termiticides or pesticides to come into direct contact with PEX piping.
- Fill the annular gap between PEX piping and slab-penetration protection devices (sleeving or PVC bend guides) at the ends of the piping to help prevent pathways for pests and the mistaken application of harmful chemicals into the space between the PEX piping and the protection device. Use only sealants that are compatible with PEX piping.
- When PEX piping is continuously sleeved below or above a slab (such as when using Pre-sleeved Uponor AquaPEX piping), never fill the space between the PEX piping and the sleeving with any liquid chemical, including pesticides or termiticides. Prevent pooling or puddling of these liquids around PEX piping.

- When it is necessary to re-treat soil near PEX piping, prevent the puddling or pooling of the termiticide/pesticide.

Water service requirements

Uponor AquaPEX piping and associated fittings meet the requirements of American Water Works Association (AWWA) C904, *Cross-linked Polyethylene (PEX) Pressure Pipe, ½" (12mm) through 3" (76mm) for Water Service*.

Use only SDR9 compression fittings listed in compliance with AWWA C800 as referenced in AWWA C904 in water service applications when transferring from PEX to a corporation or curb stop. Be sure to use insert stiffeners when assembling a compression fitting with PEX. Commonly available SDR9 compression fitting manufacturers include:

- Ford Meter Box Company, Inc.®
- Mueller Company®
- A.Y. McDonald Mfg. Co.®
- Philmac®

For ½" to 1" water meter connections, Uponor offers direct ProPEX to NPSM swivel adapters in straight, elbow and valved configurations. Refer to the Uponor product catalog for more information.

Trace wire

Uponor recommends the use of trace wire to facilitate the detection of underground pipe systems. Trace wire should be 14-gauge minimum solid copper with thermoplastic insulation suitable for direct burial. Refer to local code for further requirements.

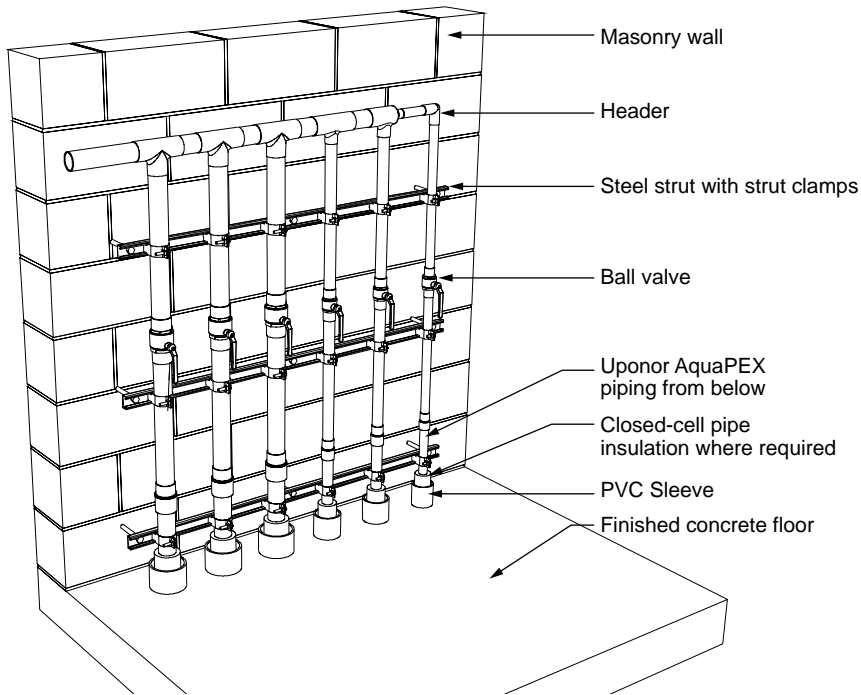

Figure 6-43: Mechanical room transition (below-grade piping)



Figure 6-44: Uponor AquaPEX below grade

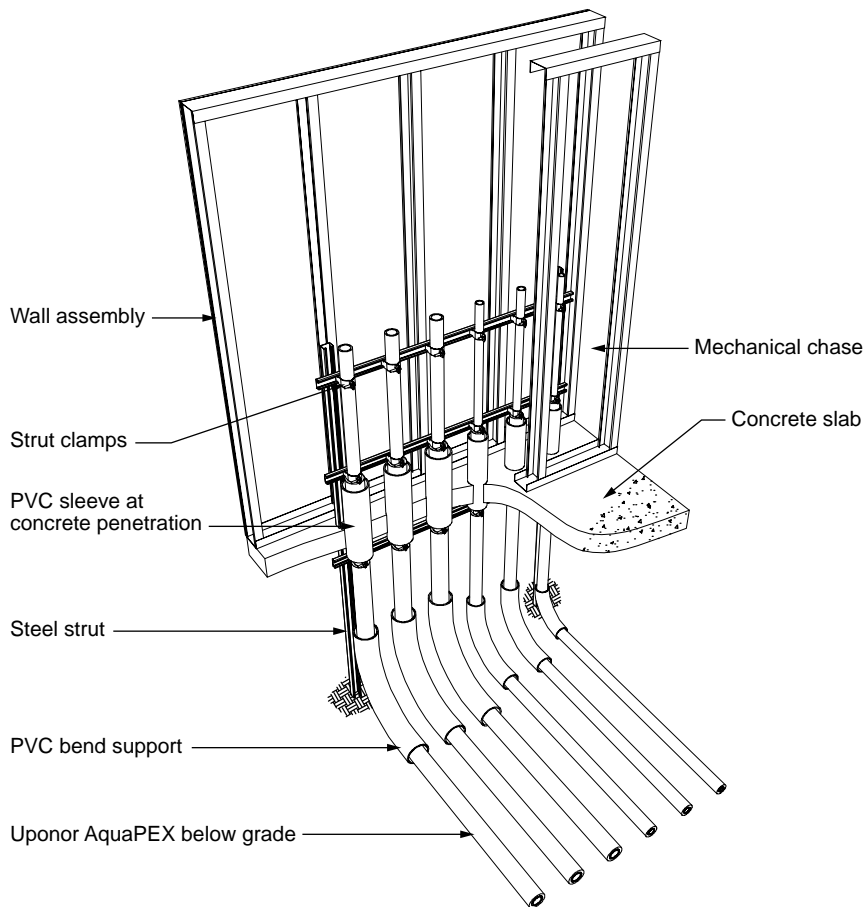

Figure 6-45: Wet-wall chase transition (below-grade piping)

Trench bottom preparation

To achieve a satisfactory installation, it is essential that the soil provides stable and continuous support for the piping.

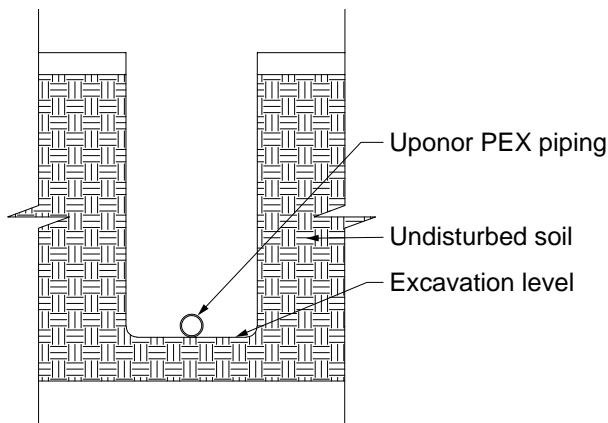

Figure 6-46: Good soil conditions — If the trench is dug smoothly, install the piping directly on the prepared bottom. The bottom must be flat with no hollows, lumps or rocks.

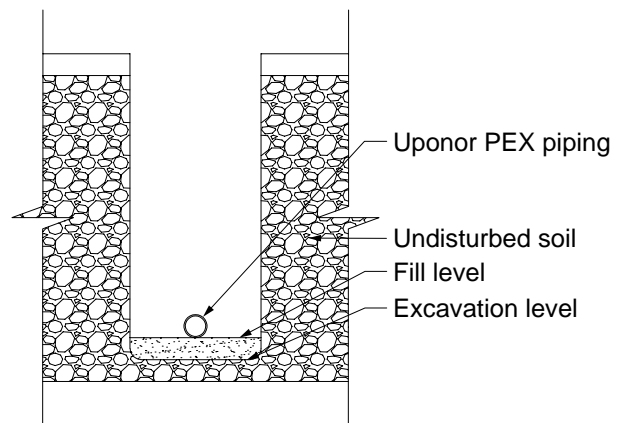

Figure 6-47: Poor soil conditions — With rocky, clay, muddy or other poor soil conditions, it may be necessary to prepare the trench bottom using granular material of such size and grading to provide a stable base. See local code for additional requirements.

Piping embedment

Proper soil selection, placement and compaction are essential in the area around the piping. Backfill around the piping with sand or gravel that has a maximum particle size of $\frac{3}{4}$ ".

Compact the initial backfill around the piping to provide adequate piping support and prevent settling. It is particularly important to adequately compact the soil around the tap connection. Uponor recommends pressurizing the piping prior to backfilling to reveal any damage. In heavy vehicular traffic areas, compact backfill to 90 percent of maximum soil density.

Do not use highly plastic clays, silts, organic materials, or sharp or large rocks as backfill in the immediate vicinity of the piping. Compact the backfill from the subgrade to a level per local code that will cover the piping 4" to 6" to provide protection around the piping

and to prevent settling that puts stress on the fittings and the piping.

For additional information about the proper installation practices of PEX piping in water-service applications, refer to AWWA C904.

Installation

Install Uponor AquaPEX piping underground in a manner that ensures external loads will not subsequently cause a decrease in the vertical dimension of the cross section of the piping that exceeds 5 percent of the outside diameter. Install Uponor AquaPEX piping in a snaking pattern with sufficient slack in the line to allow for contraction of the line due to temperature change prior to backfilling. The linear expansion rate for Uponor AquaPEX piping is approximately 1.1" per 10°F temperature change per 100 ft. of piping (27.94mm per 5.56°C temperature change per 30.48m of piping).

Note: Do not use blocking to support the piping or change the piping grade. Do not install potable-water service piping in, under or above cesspools, septic tanks, septic-tank drainage fields or pits.



Caution: Do not install Uponor AquaPEX piping in soil environments contaminated with solvents, fuels, organic compounds, pesticides or other detrimental materials that may cause permeation, corrosion, degradation or structural failure of the piping. In areas where such conditions are suspected, perform a chemical analysis of the soil or groundwater to ascertain the acceptability of Uponor AquaPEX piping for the specific installation. Check local codes for additional requirements.

Handling and repairs

Although Uponor AquaPEX piping is highly resistant to kinking and abrasion, take care while handling and installing the piping to prevent damage and possible failure of the piping. If damage occurs during installation, cut out the damaged area and repair before backfilling.

To reform kinked piping, see "Reforming kinked piping" on **page 64**. If the piping is damaged beyond its thermal-memory capacity, use a ProPEX coupling. Do not reuse or reclaim EP fittings.

H-20 loads

When installing Uponor AquaPEX under a roadway, follow the same procedures as previously indicated with the following exception: Ensure the top of the piping is 16" below the bottom of the roadbed material as specified. You can also use a suitable steel or structural conduit to sleeve the Uponor AquaPEX pipe.

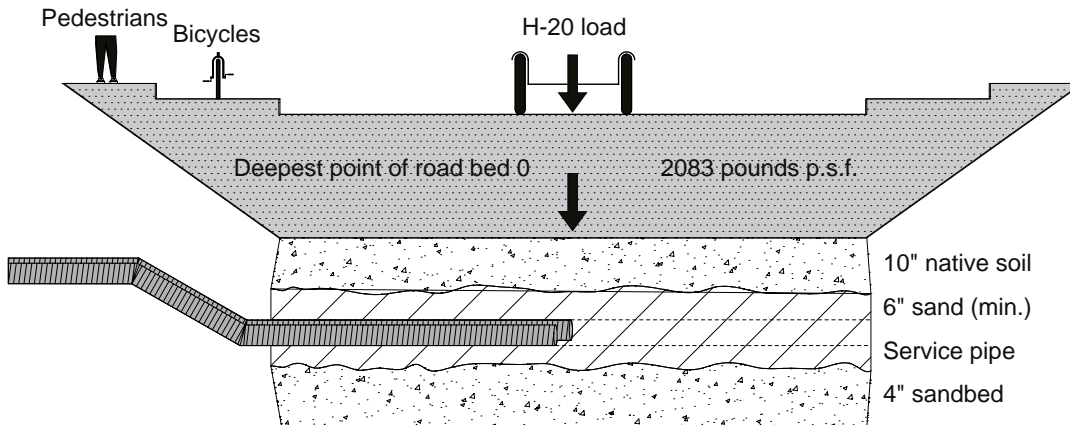

Figure 6-48: Traffic loads

Horizontal directional drilling (HDD)

Horizontal directional drilling is used when trenching or excavation is not practical. A surface-launched drilling rig provides a steerable, trenchless method of installing underground pipes along a shallow arc bore path, resulting in minimal impact to surrounding areas. It is suitable for a variety of soil conditions.

HDD is further categorized into the following types:

- Mini-HDD
 - Distances less than 600 ft.
 - Depths up to 15 ft.
 - Pipe diameters up to 12"
- Equipment pullback capability of up to 20,000 lbs. and torque less than 950 ft-lbs.
- Maxi-HDD
 - Distances greater than 600 ft.
 - Depths up to 200 ft.
 - Pipe diameters up to 48"
 - Equipment pullback capability of up to 100,000 lbs. and torque up to 80,000 ft-lbs.

Criteria for Uponor PEX piping in HDD applications

- Use Uponor PEX only as the follow pipe.
- Take precautionary steps to ensure piping does not come in contact with sharp objects.
- Do not exceed minimum bend radius of 6 times the O.D. of the piping
- Pressure test installed piping after installation to ensure the integrity of the piping has not been compromised.

For HDD applications using Uponor PEX piping, reference PPI TR-46 *Guidelines for Use of Mini-Horizontal Directional Drilling for Placement of High Density Polyethylene Pipe*.

Joining methods and fittings

Use ProPEX or approved compression fittings to connect piping to itself or to the corporation and curb stops. Approved manufacturers are Ford Meter Box Company, Mueller Company, A.Y. McDonald Mfg. Co. and Philmac.

When using compression fittings with Uponor AquaPEX piping, a plastic or stainless-steel insert stiffener is required on the inside of the piping at the connection.

For applications requiring direct burial, use Uponor ProPEX EP or LF brass fittings for large-dimension Uponor AquaPEX piping up to 3".

SDR9 Uponor PEX 12-hour pull		
Nominal pipe size	Tensile yield design (safety) factor	Allowable tensile load at 73°F/22.8°C - lbs (N)
½"	0.4	128 (569)
¾"	0.4	248 (1,103)
1"	0.4	411 (1,828)
1¼"	0.4	615 (2,735)
1½"	0.4	859 (3,821)
2"	0.4	1,465 (6,516)
2½"	0.4	2,239 (9,960)
3"	0.4	3,169 (14,096)

Table 6-9: Safe pull force

Note: The method set forth in ASTM F1804 determines the allowable tensile load.

Water system disinfection

Uponor recommends flushing an AquaPEX plumbing system with clean, potable water. When system disinfection is required, disinfect the piping in accordance with AWWA C651-86, *Standard for Disinfecting Water Mains*, or local codes.

Important: To prevent reduced service life of system components, do not allow disinfection solutions to remain in the system longer than 24 hours. Flush the system with potable water after disinfection. Use a chlorine solution of 50 parts per million (ppm) for 24 hours or 200 ppm for three hours for disinfection.

Pressure-testing procedures

It is important to properly pressure test an Uponor plumbing system in accordance with local code. If testing with air, it is important the system pressure not exceed 120 psi.

The following procedure is acceptable for testing with air, water or a mixture of both for Uponor AquaPEX piping and ProPEX fittings or hybrid systems combined with metallic piping.



Important: When pressure testing hybrid systems (i.e., those that include both thermoplastic piping materials, such as CPVC or PP-R, and Uponor AquaPEX and ProPEX fittings), isolate the Uponor system from the other thermoplastic materials in the system before following the recommended procedure.

Also, consult the appropriate pipe manufacturer's installation recommendations when testing systems comprised of other thermoplastic materials.

The intent of pressure testing a domestic-water system is to meet local code requirements while ensuring the system is free from leaks. Pressure testing is not a substitute for the correct installation of an Uponor AquaPEX and ProPEX plumbing system. It is essential the Uponor system is accurately sized, supported and protected while also accounting for thermal movement during installation.

Importance of conditioning PEX-a pipe

Uponor recommends conditioning the system at 1.5 times the test pressure, or 120

psi. The following conditioning procedure is unique to PEX-a pipe due to the high degree of crosslinking and associated thermal and elastic properties of the pipe.

When pressure is applied against the inner wall of PEX-a pipe, the internal diameter (I.D.) of the pipe will slightly increase, causing the pressure to drop while the system equalizes. After a period of 30 minutes, the PEX piping will be sufficiently conditioned to start the pressure test.

Conditioning and sustained pressure testing procedure

1. Visually confirm all connections are properly made per Uponor installation guidelines.
2. Ensure all components, fixtures and equipment not rated for the test pressure are isolated from the test system.
3. Ensure all other thermoplastic piping materials are isolated from the test system.
4. Fill the system with potable water, air or a mixture of both.
5. Condition the system to 1.5 times the required test pressure for 30 minutes. This will require constant pumping or cycling the valve and compressor to maintain a pressure of 1.5 times the test pressure. If cycling the valve and compressor, apply additional pressure once the psi has dropped 10 lbs.
6. After conditioning the system for 30 minutes, quickly relieve excess pressure by opening the valve. Close the valve when the system has reached the desired test pressure.
7. Once the valve is closed, confirm a slight rise in pressure (3 to 6 psi). This increase will occur as the pipe's I.D. is shrinking from its conditioned state to equalize at the lower pressure.
8. Visually check for leakage and monitor the pressure for the duration specified by local code. (A typical pressure test can range from 2 to 24 hours.)
9. If there is no reduction in pressure, the system is presumed to be free from leaks.
10. Flush the system as required by code.

Note: Slight fluctuations of pressure are normal due to ambient temperature changes, especially during long durations (e.g., 24 hours).

Note: Slight fluctuations of pressure are normal due to ambient temperature changes, especially during long durations (e.g., 24 hours).

Important: If using water to pressure test the system, purge all water from the system prior to the ambient air temperatures falling to 32°F (0°C). Failing to remove the water from the system during freezing temperatures can result in damage to the piping and associated equipment.

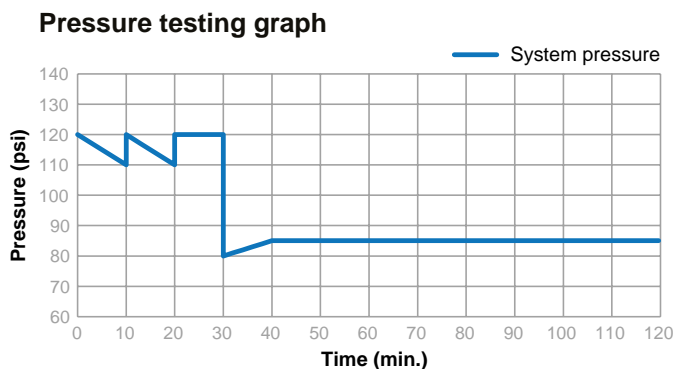

Figure 6-49: Pressure testing graph

Insulation

Some local codes require insulation on cold-water lines to mitigate condensation that can occur on the outside of the piping. This is more specific to metallic piping. The thicker, more insulating walls of PEX piping give it a very low coefficient of thermal conductivity (0.219), whereas copper has a coefficient of thermal conductivity around 173-231. In short, PEX piping does not sweat like copper piping.

Best practice is to insulate all domestic hot-water supply and return piping as well as any hydronic distribution piping to conserve energy and maintain desired fluid temperature. Uponor also recommends insulating any piping installed in an unconditioned space or poorly ventilated areas with excessive moisture content. Always comply with local and energy codes.

Icynene® spray foam insulation

Direct contact with Icynene® LD-C-50™ and MD-C-200™ spray foam insulation will not compromise the performance of Uponor PEX piping or EP fittings.

Icynene LD-C-50 is a light-density, open-cell, flexible and 100% water-blown polyurethane foam insulation. The spray formula has a nominal 0.5 lbs/ft³ density and is a free-rise material.

Icynene MD-C-200 is a medium-density, open-cell, flexible and 100% water-blown polyurethane foam insulation. The spray formula has a nominal 2 lbs/ft³ density and is a free-rise material.

Successful chemical compatibility testing has been performed on all Uponor PEX piping as well as all Uponor EP fitting materials, including Udel® GF-120, Udel® P-1700, Acudel® 22000 and Radel R® 5100. The compatibility evaluation showed no signs of cracking, crazing or reduction in ductility.

Icynene LD-C-50 and MD-C-200 must be installed by an Icynene-licensed dealer and factory-trained installer. For further information, refer to the Icynene installer's manual or contact Uponor Technical Services.

Closed-cell spray foams

Closed-cell spray foam insulation will not compromise the performance of the Uponor AquaPEX piping or brass fittings, nor will it void the warranty as long as a maximum temperature of 250°F/121.1°C is not exceeded during the chemical reaction process of installation.

The majority of closed-cell spray foams on the market are polyurethane-based. Polyurethane, the harshest of all bases, is chemically compatible with both Uponor PEX piping and brass fittings.

The primary concern in using spray foams with Uponor PEX piping is the temperature limitations of the piping relative to the temperature outputs of the chemical reaction during application of the spray foam. **Table 6-10** shows temperatures with relation to the lift or depth of foam.

As shown in **Table 6-10**, an application of 1" of foam creates a maximum of 130°F/54.4°C. As the material is applied more generously, the reaction temperature increases. If more than 2" of lift is required, Uponor recommends using a two-lift application. Apply the first layer, 2" or less. Wait 15 minutes (the time required for the heat from a 2" lift to dissipate). Then, apply the second layer.

Note: Place an initial layer of spray foam over the PEX piping prior to the entirety of the foaming to insulate the lines from the heat generated by the chemicals.

Depth of lift	Temperature
1"	130°F/54.4°C
2"	200°F/93.3°C
3"	320°F/160°C

Table 6-10: Closed-cell spray foam temperatures in relation to depth of lift

Uponor recommends closed-cell insulation for use with Uponor PEX piping and brass fittings. EP fittings require an overwrap of 4 to 6 mil poly or other suitable waterproof protection where contact is possible.

Recessed light fixtures

Do not install Uponor AquaPEX within 12" of any recessed lighting fixtures unless the piping is protected with a suitable insulation, such as closed-cell polyurethane, polyethylene and polyolefin-based products, or the light fixture is I.C.-rated.

In an application using I.C.-rated light fixtures, the minimum clearance to the PEX pipe is 2" unless protected with a suitable insulation, such as closed-cell polyurethane, polyethylene and polyolefin-based products.

Painting Uponor AquaPEX

It is acceptable to use latex and acrylic-based paint, such as 100 percent acrylic exterior latex house paint, with Uponor AquaPEX. These products will not harm the molecular structure or integrity of the PEX piping.

Termiticides/pesticides

Liquid termiticides/pesticides are often applied to treat the soil below the concrete slabs of slab-on-grade structures. The treatment creates a barrier to prevent termites and pests from infiltrating the floor of the structure. PEX piping for plumbing applications is often installed within slabs or below slabs (in trenches in the soil) below the soil that is treated. Liquid termiticides/pesticides use a liquid solvent to carry the active ingredients. These solvents can be categorized as one of two types: organic solvent-based (also known as petroleum solvent-based) and water-based (water solvent-based).

The type of solvent used in a termiticide/pesticide will affect its ability to permeate through various materials. Organic-based termiticides/pesticides have largely disappeared from the North American marketplace for this application, and the majority of products available today are water-based. Water-based products are generally safer for the environment and pose less risk of infiltration into PEX piping.

Available data indicates the solvents used in liquid termiticides/pesticides will soak into the ground and/or evaporate before they can pass through the wall of polyethylene piping. The data also indicates these solvents are prevented from passing through the wall of polyethylene piping because of the large size of the water- or organic-solvent molecules, relative to the size of the molecules in the piping itself. Once liquid solvents have dissipated or evaporated, the solids that remain behind cannot permeate through the walls of polyethylene or PEX piping because of the molecular size.

Additional research shows that water-based termiticides/pesticides are of sufficiently large molecular size to completely prevent permeation through polyethylene and PEX piping. Instances of water-based termiticides/pesticides permeating through polyethylene or PEX piping are not known. Pesticides have not been found to be corrosive or have polymer degradation.

Although all research data and anecdotal evidence strongly suggest there are no permeation issues with water-based termiticides/pesticides and PEX, take extra caution to ensure safe installation of PEX piping and to prevent misapplication or pooling/puddling of the liquid termiticides/pesticides around PEX piping.

Supporting research

A study done in 2001 in Australia, titled "Investigating the Possible Permeation of Organic Chemicals Commonly Used in Termiticide Barrier Treatments through Polyethylene Water Pipes," indicated that "migration of pesticide constituents and their associated solvents, through the polyethylene pipe, did not occur, indicating that the concentration of solvents (even in the saturated soil) was not high enough to cause permeation of the solvents through the polyethylene pipe wall (within the 16-week period of study)." The study also stated "this indicates that the concentration of these constituents in the soil in contact with the pipes was not high enough to develop a positive diffusion pressure and cause the constituents to be detected in the water." The study was conducted using organic solvent-based pesticides, which are known to be more aggressive than water-based pesticides. Therefore, the results are valid for organic solvent-based pesticides and water-based pesticides.

Research conducted by Dr. Michael R. Hoffman of the California Institute of Technology (2005) indicates that the ability of a chemical compound to permeate a material is correlated directly with the octanol-water partition coefficients of the individual organic chemicals. The octanol-

water partition coefficient is a relative measure of the hydrophobic nature of the organic compounds. In spite of a measurable tendency to partition into plastic material, the ability of these compounds is retarded substantially given the low measured diffusion coefficients for selected chemicals. For example, a PEX piping wall thickness of 5mm and a typical diffusion coefficient for organic compound migration of 1.0×10^{-12} cm²/s, the time to permeate through the walls, would be $2.5 \times 1,011$ seconds or approximately 8,000 years. If the wall thickness was reduced to 2mm, then the time to permeate completely through the pipe wall would be reduced to 1,300 years.

Note: Crosslinked polyethylene (PEX) piping is assumed to behave similarly to polyethylene water piping.

Appendix A: *Fluid properties*

100% water

Temperature °F (°C)	Density (lbm/ft ³)	Dynamic viscosity [lbm/(ft*sec)]
	ρ	μ
40 (4.44)	62.42	1.31E-03
45 (7.22)	62.42	1.09E-03
50 (10)	62.41	8.78E-04
55 (12.78)	62.39	8.16E-04
60 (15.56)	62.36	7.54E-04
65 (18.33)	62.33	7.05E-04
70 (21.11)	62.30	6.56E-04
80 (26.67)	62.22	5.76E-04
90 (32.22)	62.12	5.12E-04
100 (37.77)	62.00	4.58E-04
110 (43.33)	61.86	4.13E-04
120 (48.89)	61.71	3.74E-04
130 (54.44)	61.55	3.42E-04
140 (60)	61.38	3.14E-04
150 (65.56)	61.19	2.89E-04
160 (71.11)	60.99	2.68E-04
170 (76.67)	60.79	2.48E-04
180 (82.22)	60.57	2.32E-04
190 (87.78)	60.35	2.17E-04
200 (93.33)	60.12	2.04E-04

Appendix B:

Uponor PEX friction loss tables

¼" Uponor AquaPEX (100% water)

psi loss per 100 feet of tubing									
Velocity (ft/s)	gpm	40°F 4°C	60°F 16°C	80°F 27°C	100°F 38°C	120°F 49°C	140°F 60°C	160°F 71°C	180°F 82°C
1.5	0.21	4.18	3.50	3.22	3.00	2.82	2.68	2.55	2.45
1.6	0.23	4.65	3.90	3.59	3.35	3.16	3.00	2.86	2.74
1.7	0.24	5.15	4.32	3.98	3.72	3.50	3.33	3.17	3.04
1.8	0.26	5.67	4.76	4.39	4.10	3.87	3.67	3.51	3.36
1.9	0.27	6.20	5.22	4.82	4.50	4.25	4.03	3.85	3.70
2.0	0.28	6.76	5.70	5.26	4.92	4.64	4.41	4.21	4.04
2.1	0.30	7.34	6.19	5.72	5.35	5.05	4.80	4.59	4.40
2.2	0.31	7.93	6.70	6.20	5.80	5.47	5.21	4.98	4.78
2.3	0.33	8.55	7.23	6.69	6.26	5.91	5.63	5.38	5.16
2.4	0.34	9.19	7.78	7.20	6.74	6.37	6.06	5.80	5.57
2.5	0.36	9.84	8.34	7.72	7.23	6.84	6.51	6.23	5.98
2.6	0.37	10.52	8.92	8.26	7.74	7.32	6.97	6.67	6.41
2.7	0.38	11.21	9.52	8.82	8.27	7.82	7.45	7.13	6.85
2.8	0.40	11.92	10.13	9.39	8.81	8.33	7.94	7.60	7.30
2.9	0.41	12.65	10.76	9.98	9.36	8.86	8.44	8.08	7.77
3.0	0.43	13.40	11.41	10.58	9.93	9.40	8.96	8.58	8.25
3.1	0.44	14.17	12.07	11.20	10.51	9.95	9.49	9.09	8.74
3.2	0.46	14.95	12.75	11.83	11.11	10.52	10.03	9.61	9.24
3.3	0.47	15.76	13.44	12.48	11.72	11.10	10.59	10.15	9.76
3.4	0.48	16.58	14.15	13.14	12.35	11.70	11.16	10.69	10.29
3.5	0.50	17.42	14.88	13.82	12.99	12.31	11.74	11.26	10.83
3.6	0.51	18.27	15.62	14.51	13.64	12.93	12.34	11.83	11.39
3.7	0.53	19.15	16.37	15.22	14.31	13.57	12.95	12.42	11.95
3.8	0.54	20.04	17.15	15.95	15.00	14.22	13.58	13.02	12.53
3.9	0.55	20.95	17.94	16.68	15.69	14.89	14.21	13.63	13.13
4.0	0.57	21.88	18.74	17.44	16.41	15.56	14.86	14.26	13.73
4.1	0.58	22.82	19.56	18.20	17.13	16.25	15.52	14.90	14.35
4.2	0.60	23.78	20.39	18.98	17.87	16.96	16.20	15.55	14.98
4.3	0.61	24.76	21.24	19.78	18.62	17.68	16.89	16.21	15.62
4.4	0.63	25.75	22.11	20.59	19.39	18.41	17.59	16.88	16.27
4.5	0.64	26.76	22.99	21.41	20.17	19.15	18.30	17.57	16.94
4.6	0.65	27.79	23.88	22.25	20.96	19.91	19.03	18.27	17.61
4.7	0.67	28.83	24.79	23.11	21.77	20.68	19.77	18.99	18.30
4.8	0.68	29.90	25.71	23.97	22.59	21.46	20.52	19.71	19.00
4.9	0.70	30.97	26.65	24.85	23.43	22.26	21.29	20.45	19.72
5.0	0.71	32.07	27.61	25.75	24.28	23.07	22.07	21.20	20.44
5.1	0.73	33.18	28.58	26.66	25.14	23.89	22.86	21.96	21.18
5.2	0.74	34.30	29.56	27.58	26.01	24.73	23.66	22.73	21.93
5.3	0.75	35.45	30.56	28.52	26.90	25.58	24.47	23.52	22.69
5.4	0.77	36.61	31.57	29.47	27.80	26.44	25.30	24.32	23.46
5.5	0.78	37.78	32.60	30.43	28.72	27.31	26.14	25.13	24.24
5.6	0.80	38.97	33.64	31.41	29.64	28.20	26.99	25.95	25.04
5.7	0.81	40.18	34.69	32.40	30.58	29.10	27.86	26.78	25.85
5.8	0.82	41.40	35.76	33.41	31.54	30.01	28.73	27.63	26.67
5.9	0.84	42.64	36.85	34.43	32.51	30.93	29.62	28.49	27.50
6.0	0.85	43.90	37.94	35.46	33.49	31.87	30.52	29.36	28.34
6.1	0.87	45.17	39.06	36.50	34.48	32.82	31.44	30.24	29.19
6.2	0.88	46.45	40.18	37.56	35.49	33.78	32.36	31.13	30.06
6.3	0.90	47.75	41.33	38.64	36.50	34.76	33.30	32.04	30.94
6.4	0.91	49.07	42.48	39.72	37.54	35.74	34.25	32.95	31.82
6.5	0.92	50.41	43.65	40.82	38.58	36.74	35.21	33.88	32.73
6.6	0.94	51.75	44.83	41.94	39.64	37.76	36.18	34.82	33.64
6.7	0.95	53.12	46.03	43.06	40.71	38.78	37.17	35.78	34.56

¼" Uponor AquaPEX (100% water)

psi loss per 100 feet of tubing									
Velocity (ft/s)	gpm	40°F 4°C	60°F 16°C	80°F 27°C	100°F 38°C	120°F 49°C	140°F 60°C	160°F 71°C	180°F 82°C
6.8	0.97	54.50	47.24	44.20	41.79	39.82	38.17	36.74	35.49
6.9	0.98	55.89	48.47	45.36	42.89	40.87	39.18	37.72	36.44
7.0	1.00	57.30	49.70	46.52	44.00	41.93	40.20	38.70	37.40
7.1	1.01	58.73	50.96	47.70	45.12	43.00	41.23	39.70	38.37
7.2	1.02	60.17	52.22	48.90	46.25	44.09	42.28	40.71	39.35
7.3	1.04	61.63	53.50	50.10	47.40	45.19	43.34	41.74	40.34
7.4	1.05	63.10	54.80	51.32	48.56	46.30	44.41	42.77	41.34
7.5	1.07	64.58	56.10	52.55	49.73	47.42	45.49	43.82	42.36
7.6	1.08	66.09	57.43	53.80	50.92	48.55	46.58	44.87	43.38
7.7	1.09	67.60	58.76	55.06	52.12	49.70	47.69	45.94	44.42
7.8	1.11	69.13	60.11	56.33	53.33	50.86	48.80	47.02	45.47
7.9	1.12	70.68	61.47	57.61	54.55	52.03	49.93	48.11	46.53
8.0	1.14	72.24	62.85	58.91	55.78	53.22	51.07	49.22	47.60
8.1	1.15	73.82	64.24	60.22	57.03	54.41	52.23	50.33	48.68
8.2	1.17	75.41	65.64	61.54	58.29	55.62	53.39	51.46	49.77
8.3	1.18	77.02	67.05	62.88	59.56	56.84	54.56	52.59	50.87
8.4	1.19	78.64	68.48	64.23	60.85	58.07	55.75	53.74	51.99
8.5	1.21	80.27	69.93	65.59	62.14	59.31	56.95	54.90	53.12
8.6	1.22	81.92	71.38	66.96	63.45	60.57	58.16	56.08	54.25
8.7	1.24	83.59	72.85	68.35	64.77	61.84	59.38	57.26	55.40
8.8	1.25	85.27	74.34	69.75	66.11	63.12	60.62	58.45	56.56
8.9	1.27	86.96	75.83	71.16	67.45	64.41	61.86	59.66	57.73
9.0	1.28	88.67	77.34	72.59	68.81	65.71	63.12	60.88	58.92
9.1	1.29	90.40	78.86	74.03	70.18	67.03	64.39	62.11	60.11
9.2	1.31	92.14	80.40	75.48	71.57	68.35	65.67	63.35	61.31
9.3	1.32	93.89	81.95	76.94	72.96	69.69	66.96	64.60	62.53
9.4	1.34	95.66	83.51	78.42	74.37	71.04	68.27	65.86	63.76
9.5	1.35	97.44	85.09	79.91	75.79	72.41	69.58	67.13	64.99
9.6	1.37	99.24	86.68	81.41	77.22	73.78	70.91	68.42	66.24
9.7	1.38	101.05	88.28	82.92	78.67	75.17	72.25	69.71	67.50
9.8	1.39	102.87	89.89	84.45	80.12	76.57	73.60	71.02	68.77
9.9	1.41	104.71	91.52	85.99	81.59	77.98	74.96	72.34	70.05
10.0	1.42	106.57	93.16	87.54	83.07	79.40	76.33	73.67	71.35
10.1	1.44	108.43	94.82	89.10	84.56	80.83	77.72	75.01	72.65
10.2	1.45	110.32	96.49	90.68	86.07	82.28	79.11	76.36	73.96
10.3	1.46	112.21	98.17	92.27	87.58	83.73	80.52	77.73	75.29
10.4	1.48	114.12	99.86	93.87	89.11	85.20	81.94	79.10	76.63
10.5	1.49	116.05	101.57	95.49	90.65	86.68	83.37	80.49	77.97
10.6	1.51	117.99	103.28	97.11	92.21	88.18	84.81	81.89	79.33
10.7	1.52	119.94	105.02	98.75	93.77	89.68	86.26	83.29	80.70
10.8	1.54	121.91	106.76	100.40	95.35	91.19	87.72	84.71	82.08
10.9	1.55	123.89	108.52	102.07	96.94	92.72	89.20	86.14	83.47
11.0	1.56	125.89	110.29	103.74	98.54	94.26	90.69	87.58	84.87
11.1	1.58	127.90	112.07	105.43	100.15	95.81	92.18	89.04	86.29
11.2	1.59	129.92	113.87	107.13	101.77	97.37	93.69	90.50	87.71
11.3	1.61	131.96	115.68	108.85	103.41	98.95	95.21	91.98	89.14
11.4	1.62	134.01	117.50	110.57	105.06	100.53	96.75	93.46	90.59
11.5	1.64	136.08	119.34	112.31	106.72	102.13	98.29	94.96	92.05
11.6	1.65	138.16	121.19	114.06	108.39	103.74	99.84	96.47	93.51
11.7	1.66	140.25	123.05	115.82	110.08	105.36	101.41	97.99	94.99
11.8	1.68	142.36	124.92	117.60	111.77	106.99	102.99	99.52	96.48
11.9	1.69	144.49	126.81	119.38	113.48	108.63	104.57	101.06	97.98
12.0	1.71	146.62	128.70	121.18	115.20	110.28	106.17	102.61	99.49

Uponor PEX friction loss tables

3/8" Uponor AquaPEX (100% water)

psi loss per 100 feet of tubing										
Velocity (ft/s)	gpm	40°F 4°C	60°F 16°C	80°F 27°C	100°F 38°C	120°F 49°C	140°F 60°C	160°F 71°C	180°F 82°C	
1.5	0.45	2.54	2.14	1.98	1.85	1.74	1.66	1.58	1.52	
1.6	0.48	2.83	2.39	2.21	2.07	1.95	1.85	1.77	1.70	
1.7	0.51	3.14	2.65	2.45	2.29	2.17	2.06	1.97	1.89	
1.8	0.54	3.45	2.92	2.70	2.53	2.39	2.27	2.17	2.09	
1.9	0.57	3.78	3.21	2.97	2.78	2.63	2.50	2.39	2.29	
2.0	0.60	4.13	3.50	3.24	3.04	2.87	2.73	2.61	2.51	
2.1	0.63	4.48	3.81	3.53	3.31	3.13	2.98	2.85	2.73	
2.2	0.66	4.85	4.12	3.82	3.59	3.39	3.23	3.09	2.97	
2.3	0.69	5.23	4.45	4.13	3.87	3.66	3.49	3.34	3.21	
2.4	0.72	5.62	4.79	4.44	4.17	3.95	3.76	3.60	3.46	
2.5	0.75	6.03	5.14	4.77	4.48	4.24	4.04	3.87	3.72	
2.6	0.78	6.44	5.50	5.11	4.79	4.54	4.33	4.14	3.98	
2.7	0.81	6.87	5.87	5.45	5.12	4.85	4.62	4.43	4.26	
2.8	0.84	7.31	6.25	5.81	5.46	5.17	4.93	4.72	4.54	
2.9	0.87	7.76	6.64	6.17	5.80	5.50	5.24	5.02	4.83	
3.0	0.90	8.22	7.04	6.55	6.15	5.83	5.57	5.33	5.13	
3.1	0.93	8.70	7.45	6.93	6.52	6.18	5.90	5.65	5.44	
3.2	0.96	9.18	7.87	7.33	6.89	6.53	6.24	5.98	5.75	
3.3	0.99	9.68	8.30	7.73	7.27	6.90	6.58	6.31	6.08	
3.4	1.02	10.19	8.75	8.14	7.66	7.27	6.94	6.65	6.41	
3.5	1.05	10.71	9.20	8.56	8.06	7.65	7.30	7.00	6.74	
3.6	1.08	11.24	9.66	9.00	8.47	8.04	7.68	7.36	7.09	
3.7	1.11	11.78	10.13	9.44	8.89	8.43	8.06	7.73	7.44	
3.8	1.14	12.33	10.61	9.89	9.31	8.84	8.45	8.10	7.80	
3.9	1.17	12.89	11.10	10.35	9.75	9.25	8.84	8.49	8.17	
4.0	1.20	13.47	11.60	10.81	10.19	9.68	9.25	8.88	8.55	
4.1	1.23	14.05	12.11	11.29	10.64	10.11	9.66	9.27	8.93	
4.2	1.26	14.65	12.63	11.78	11.10	10.55	10.08	9.68	9.33	
4.3	1.29	15.25	13.16	12.27	11.57	10.99	10.51	10.09	9.73	
4.4	1.32	15.87	13.69	12.78	12.05	11.45	10.95	10.51	10.13	
4.5	1.35	16.50	14.24	13.29	12.54	11.91	11.39	10.94	10.55	
4.6	1.38	17.13	14.80	13.81	13.03	12.39	11.85	11.38	10.97	
4.7	1.41	17.78	15.36	14.35	13.53	12.87	12.31	11.82	11.40	
4.8	1.44	18.44	15.94	14.89	14.05	13.36	12.78	12.28	11.84	
4.9	1.47	19.11	16.52	15.43	14.57	13.85	13.25	12.73	12.28	
5.0	1.50	19.79	17.12	15.99	15.10	14.36	13.74	13.20	12.73	
5.1	1.53	20.48	17.72	16.56	15.63	14.87	14.23	13.68	13.19	
5.2	1.56	21.18	18.33	17.13	16.18	15.39	14.73	14.16	13.66	
5.3	1.59	21.89	18.95	17.72	16.73	15.92	15.24	14.65	14.13	
5.4	1.62	22.61	19.58	18.31	17.29	16.46	15.75	15.15	14.61	
5.5	1.65	23.34	20.22	18.91	17.86	17.00	16.28	15.65	15.10	
5.6	1.68	24.08	20.87	19.52	18.44	17.55	16.81	16.16	15.60	
5.7	1.71	24.83	21.53	20.14	19.03	18.11	17.35	16.68	16.10	
5.8	1.74	25.59	22.20	20.77	19.62	18.68	17.89	17.21	16.61	
5.9	1.77	26.36	22.87	21.40	20.23	19.26	18.45	17.74	17.13	
6.0	1.80	27.13	23.56	22.04	20.84	19.84	19.01	18.28	17.65	
6.1	1.83	27.92	24.25	22.70	21.46	20.44	19.58	18.83	18.18	
6.2	1.86	28.72	24.95	23.36	22.09	21.04	20.16	19.39	18.72	
6.3	1.89	29.53	25.66	24.03	22.72	21.64	20.74	19.95	19.27	
6.4	1.92	30.35	26.38	24.70	23.36	22.26	21.33	20.53	19.82	
6.5	1.95	31.18	27.11	25.39	24.02	22.88	21.93	21.10	20.38	
6.6	1.98	32.02	27.85	26.08	24.68	23.51	22.54	21.69	20.95	
6.7	2.01	32.87	28.59	26.79	25.34	24.15	23.15	22.28	21.52	

3/8" Uponor AquaPEX (100% water)

psi loss per 100 feet of tubing										
Velocity (ft/s)	gpm	40°F 4°C	60°F 16°C	80°F 27°C	100°F 38°C	120°F 49°C	140°F 60°C	160°F 71°C	180°F 82°C	
6.8	2.04	33.73	29.35	27.50	26.02	24.80	23.77	22.88	22.10	
6.9	2.07	34.59	30.11	28.22	26.70	25.45	24.40	23.49	22.69	
7.0	2.10	35.47	30.88	28.94	27.39	26.11	25.04	24.10	23.29	
7.1	2.13	36.36	31.66	29.68	28.09	26.78	25.68	24.73	23.89	
7.2	2.16	37.25	32.45	30.42	28.80	27.46	26.33	25.36	24.50	
7.3	2.19	38.16	33.25	31.17	29.51	28.14	26.99	25.99	25.12	
7.4	2.22	39.08	34.06	31.94	30.24	28.84	27.66	26.64	25.74	
7.5	2.25	40.00	34.87	32.70	30.97	29.54	28.33	27.29	26.37	
7.6	2.28	40.93	35.70	33.48	31.71	30.24	29.01	27.94	27.01	
7.7	2.31	41.88	36.53	34.26	32.45	30.96	29.70	28.61	27.65	
7.8	2.34	42.83	37.37	35.06	33.21	31.68	30.40	29.28	28.30	
7.9	2.37	43.79	38.22	35.86	33.97	32.41	31.10	29.96	28.96	
8.0	2.40	44.77	39.08	36.67	34.74	33.15	31.81	30.65	29.63	
8.1	2.43	45.75	39.94	37.48	35.52	33.89	32.53	31.34	30.30	
8.2	2.46	46.74	40.82	38.31	36.30	34.64	33.25	32.04	30.98	
8.3	2.49	47.74	41.70	39.14	37.09	35.40	33.98	32.75	31.66	
8.4	2.52	48.75	42.59	39.98	37.90	36.17	34.72	33.46	32.36	
8.5	2.55	49.77	43.49	40.83	38.70	36.94	35.47	34.18	33.06	
8.6	2.58	50.79	44.40	41.69	39.52	37.73	36.22	34.91	33.76	
8.7	2.61	51.83	45.32	42.55	40.34	38.52	36.98	35.65	34.48	
8.8	2.64	52.88	46.24	43.43	41.17	39.31	37.75	36.39	35.20	
8.9	2.67	53.93	47.17	44.31	42.01	40.12	38.53	37.14	35.92	
9.0	2.70	55.00	48.11	45.20	42.86	40.93	39.31	37.90	36.66	
9.1	2.73	56.07	49.06	46.09	43.71	41.75	40.10	38.66	37.40	
9.2	2.76	57.15	50.02	47.00	44.58	42.57	40.89	39.43	38.14	
9.3	2.79	58.24	50.99	47.91	45.45	43.41	41.70	40.21	38.90	
9.4	2.82	59.34	51.96	48.83	46.32	44.25	42.51	40.99	39.66	
9.5	2.85	60.45	52.94	49.76	47.21	45.10	43.33	41.78	40.43	
9.6	2.88	61.57	53.94	50.69	48.10	45.95	44.15	42.58	41.20	
9.7	2.91	62.70	54.93	51.64	49.00	46.82	44.98	43.39	41.98	
9.8	2.94	63.84	55.94	52.59	49.91	47.69	45.82	44.20	42.77	
9.9	2.97	64.98	56.96	53.55	50.82	48.56	46.67	45.02	43.57	
10.0	3.00	66.14	57.98	54.52	51.74	49.45	47.52	45.84	44.37	
10.1	3.03	67.30	59.01	55.49	52.67	50.34	48.38	46.67	45.18	
10.2	3.06	68.48	60.05	56.47	53.61	51.24	49.25	47.51	45.99	
10.3	3.09	69.66	61.10	57.46	54.55	52.15	50.12	48.36	46.81	
10.4	3.12	70.85	62.15	58.46	55.51	53.06	51.01	49.21	47.64	
10.5	3.15	72.05	63.22	59.47	56.47	53.98	51.89	50.07	48.48	
10.6	3.18	73.26	64.29	60.48	57.43	54.91	52.79	50.94	49.32	
10.7	3.21	74.47	65.37	61.50	58.41	55.84	53.69	51.82	50.17	
10.8	3.24	75.70	66.46	62.53	59.39	56.79	54.60	52.70	51.02	
10.9	3.27	76.93	67.55	63.57	60.38	57.74	55.52	53.58	51.89	
11.0	3.30	78.18	68.66	64.61	61.37	58.69	56.44	54.48	52.75	
11.1	3.33	79.43	69.77	65.67	62.38	59.66	57.37	55.38	53.63	
11.2	3.36	80.69	70.89	66.73	63.39	60.63	58.31	56.29	54.51	
11.3	3.39	81.96	72.02	67.79	64.41	61.61	59.25	57.20	55.40	
11.4	3.42	83.24	73.16	68.87	65.43	62.59	60.21	58.12	56.30	
11.5	3.45	84.53	74.30	69.95	66.47	63.59	61.16	59.05	57.20	
11.6	3.48	85.83	75.45	71.04	67.51	64.59	62.13	59.99	58.11	
11.7	3.51	87.13	76.61	72.14	68.56	65.59	63.10	60.93	59.02	
11.8	3.54	88.45	77.78	73.25	69.61	66.61	64.08	61.88	59.94	
11.9	3.57	89.77	78.96	74.36	70.68	67.63	65.07	62.83	60.87	
12.0	3.60	91.10	80.14	75.48	71.75	68.66	66.06	63.79	61.81	

Uponor PEX friction loss tables

½" Uponor AquaPEX (100% water)

psi loss per 100 feet of tubing										
Velocity (ft/s)	gpm	40°F 4°C	60°F 16°C	80°F 27°C	100°F 38°C	120°F 49°C	140°F 60°C	160°F 71°C	180°F 82°C	
1.5	0.83	1.70	1.44	1.33	1.25	1.18	1.12	1.07	1.03	
1.6	0.88	1.89	1.61	1.49	1.40	1.32	1.26	1.20	1.15	
1.7	0.94	2.10	1.79	1.66	1.55	1.47	1.40	1.34	1.28	
1.8	0.99	2.31	1.97	1.83	1.71	1.62	1.54	1.48	1.42	
1.9	1.05	2.54	2.16	2.01	1.88	1.78	1.70	1.62	1.56	
2.0	1.10	2.77	2.36	2.19	2.06	1.95	1.86	1.78	1.71	
2.1	1.16	3.01	2.57	2.39	2.24	2.12	2.02	1.94	1.86	
2.2	1.22	3.26	2.78	2.59	2.43	2.30	2.19	2.10	2.02	
2.3	1.27	3.51	3.01	2.80	2.63	2.49	2.37	2.27	2.19	
2.4	1.33	3.78	3.24	3.01	2.83	2.68	2.56	2.45	2.36	
2.5	1.38	4.05	3.47	3.23	3.04	2.88	2.75	2.63	2.53	
2.6	1.44	4.33	3.72	3.46	3.25	3.09	2.94	2.82	2.71	
2.7	1.49	4.62	3.97	3.70	3.48	3.30	3.15	3.02	2.90	
2.8	1.55	4.92	4.23	3.94	3.71	3.51	3.35	3.22	3.10	
2.9	1.60	5.23	4.49	4.19	3.94	3.74	3.57	3.42	3.29	
3.0	1.66	5.54	4.77	4.44	4.18	3.97	3.79	3.63	3.50	
3.1	1.71	5.86	5.05	4.70	4.43	4.20	4.02	3.85	3.71	
3.2	1.77	6.19	5.33	4.97	4.68	4.45	4.25	4.07	3.92	
3.3	1.82	6.53	5.63	5.25	4.94	4.69	4.48	4.30	4.14	
3.4	1.88	6.87	5.93	5.53	5.21	4.95	4.73	4.54	4.37	
3.5	1.93	7.22	6.23	5.82	5.48	5.21	4.98	4.78	4.60	
3.6	1.99	7.58	6.55	6.11	5.76	5.47	5.23	5.02	4.84	
3.7	2.04	7.95	6.87	6.41	6.04	5.74	5.49	5.27	5.08	
3.8	2.10	8.32	7.19	6.72	6.34	6.02	5.76	5.53	5.33	
3.9	2.15	8.71	7.53	7.03	6.63	6.30	6.03	5.79	5.58	
4.0	2.21	9.10	7.87	7.35	6.93	6.59	6.30	6.05	5.84	
4.1	2.26	9.49	8.22	7.68	7.24	6.89	6.59	6.33	6.10	
4.2	2.32	9.90	8.57	8.01	7.56	7.19	6.88	6.60	6.37	
4.3	2.38	10.31	8.93	8.35	7.88	7.49	7.17	6.89	6.64	
4.4	2.43	10.73	9.30	8.69	8.20	7.80	7.47	7.17	6.92	
4.5	2.49	11.15	9.67	9.04	8.54	8.12	7.77	7.47	7.20	
4.6	2.54	11.59	10.05	9.40	8.88	8.44	8.08	7.77	7.49	
4.7	2.60	12.03	10.44	9.76	9.22	8.77	8.40	8.07	7.78	
4.8	2.65	12.48	10.83	10.13	9.57	9.11	8.72	8.38	8.08	
4.9	2.71	12.93	11.23	10.50	9.92	9.45	9.04	8.69	8.39	
5.0	2.76	13.39	11.63	10.88	10.29	9.79	9.37	9.01	8.69	
5.1	2.82	13.86	12.04	11.27	10.65	10.14	9.71	9.34	9.01	
5.2	2.87	14.34	12.46	11.66	11.02	10.50	10.05	9.67	9.33	
5.3	2.93	14.82	12.88	12.06	11.40	10.86	10.40	10.00	9.65	
5.4	2.98	15.31	13.31	12.47	11.79	11.23	10.75	10.34	9.98	
5.5	3.04	15.80	13.75	12.88	12.18	11.60	11.11	10.69	10.31	
5.6	3.09	16.31	14.19	13.29	12.57	11.98	11.47	11.04	10.65	
5.7	3.15	16.82	14.64	13.72	12.97	12.36	11.84	11.39	11.00	
5.8	3.20	17.34	15.10	14.14	13.38	12.75	12.22	11.75	11.34	
5.9	3.26	17.86	15.56	14.58	13.79	13.14	12.59	12.12	11.70	
6.0	3.31	18.39	16.02	15.02	14.21	13.54	12.98	12.49	12.06	
6.1	3.37	18.93	16.50	15.46	14.63	13.95	13.37	12.86	12.42	
6.2	3.42	19.47	16.98	15.91	15.06	14.36	13.76	13.24	12.79	
6.3	3.48	20.02	17.46	16.37	15.50	14.77	14.16	13.63	13.16	
6.4	3.54	20.58	17.95	16.83	15.94	15.19	14.56	14.02	13.54	
6.5	3.59	21.14	18.45	17.30	16.38	15.62	14.97	14.41	13.92	
6.6	3.65	21.72	18.95	17.78	16.83	16.05	15.39	14.81	14.31	
6.7	3.70	22.29	19.46	18.26	17.29	16.49	15.81	15.22	14.70	

½" Uponor AquaPEX (100% water)

psi loss per 100 feet of tubing										
Velocity (ft/s)	gpm	40°F 4°C	60°F 16°C	80°F 27°C	100°F 38°C	120°F 49°C	140°F 60°C	160°F 71°C	180°F 82°C	
6.8	3.76	22.88	19.98	18.74	17.75	16.93	16.23	15.63	15.10	
6.9	3.81	23.47	20.50	19.23	18.22	17.37	16.66	16.04	15.50	
7.0	3.87	24.07	21.03	19.73	18.69	17.83	17.10	16.46	15.91	
7.1	3.92	24.67	21.56	20.23	19.17	18.28	17.54	16.89	16.32	
7.2	3.98	25.28	22.10	20.74	19.65	18.75	17.98	17.32	16.73	
7.3	4.03	25.90	22.64	21.25	20.14	19.21	18.43	17.75	17.16	
7.4	4.09	26.52	23.19	21.77	20.63	19.69	18.89	18.19	17.58	
7.5	4.14	27.15	23.75	22.30	21.13	20.17	19.35	18.64	18.01	
7.6	4.20	27.79	24.31	22.83	21.64	20.65	19.82	19.09	18.45	
7.7	4.25	28.43	24.88	23.37	22.15	21.14	20.29	19.54	18.89	
7.8	4.31	29.08	25.46	23.91	22.66	21.63	20.76	20.00	19.33	
7.9	4.36	29.74	26.04	24.46	23.18	22.13	21.24	20.47	19.78	
8.0	4.42	30.40	26.62	25.01	23.71	22.63	21.73	20.93	20.24	
8.1	4.47	31.07	27.21	25.57	24.24	23.14	22.22	21.41	20.70	
8.2	4.53	31.75	27.81	26.13	24.78	23.66	22.71	21.89	21.16	
8.3	4.58	32.43	28.41	26.70	25.32	24.18	23.21	22.37	21.63	
8.4	4.64	33.12	29.02	27.27	25.87	24.70	23.72	22.86	22.10	
8.5	4.70	33.81	29.64	27.85	26.42	25.23	24.23	23.35	22.58	
8.6	4.75	34.51	30.26	28.44	26.98	25.76	24.74	23.85	23.06	
8.7	4.81	35.22	30.88	29.03	27.54	26.30	25.26	24.35	23.55	
8.8	4.86	35.93	31.52	29.63	28.11	26.85	25.79	24.86	24.04	
8.9	4.92	36.65	32.15	30.23	28.68	27.40	26.32	25.37	24.54	
9.0	4.97	37.38	32.80	30.84	29.26	27.95	26.85	25.89	25.04	
9.1	5.03	38.11	33.45	31.45	29.85	28.51	27.39	26.41	25.54	
9.2	5.08	38.85	34.10	32.07	30.44	29.08	27.93	26.93	26.05	
9.3	5.14	39.59	34.76	32.69	31.03	29.65	28.48	27.46	26.57	
9.4	5.19	40.34	35.43	33.32	31.63	30.22	29.04	28.00	27.09	
9.5	5.25	41.10	36.10	33.96	32.23	30.80	29.60	28.54	27.61	
9.6	5.30	41.86	36.77	34.60	32.84	31.39	30.16	29.08	28.14	
9.7	5.36	42.63	37.46	35.24	33.46	31.98	30.73	29.63	28.67	
9.8	5.41	43.41	38.14	35.89	34.08	32.57	31.30	30.19	29.21	
9.9	5.47	44.19	38.84	36.55	34.70	33.17	31.88	30.75	29.75	
10.0	5.52	44.98	39.54	37.21	35.33	33.78	32.46	31.31	30.30	
10.1	5.58	45.77	40.24	37.88	35.97	34.39	33.05	31.88	30.85	
10.2	5.63	46.57	40.95	38.55	36.61	35.00	33.64	32.45	31.41	
10.3	5.69	47.38	41.67	39.22	37.26	35.62	34.24	33.03	31.97	
10.4	5.74	48.19	42.39	39.91	37.91	36.24	34.84	33.61	32.53	
10.5	5.80	49.01	43.12	40.59	38.56	36.87	35.45	34.20	33.10	
10.6	5.86	49.84	43.85	41.29	39.22	37.51	36.06	34.79	33.68	
10.7	5.91	50.67	44.59	41.99	39.89	38.15	36.68	35.39	34.26	
10.8	5.97	51.50	45.33	42.69	40.56	38.79	37.30	35.99	34.84	
10.9	6.02	52.35	46.08	43.40	41.24	39.44	37.92	36.60	35.43	
11.0	6.08	53.20	46.84	44.11	41.92	40.09	38.55	37.21	36.02	
11.1	6.13	54.05	47.60	44.83	42.60	40.75	39.19	37.82	36.62	
11.2	6.19	54.91	48.36	45.56	43.29	41.42	39.83	38.44	37.22	
11.3	6.24	55.78	49.13	46.29	43.99	42.08	40.47	39.07	37.82	
11.4	6.30	56.65	49.91	47.02	44.69	42.76	41.12	39.69	38.43	
11.5	6.35	57.53	50.69	47.76	45.40	43.44	41.78	40.33	39.05	
11.6	6.41	58.42	51.48	48.51	46.11	44.12	42.44	40.97	39.67	
11.7	6.46	59.31	52.27	49.26	46.83	44.81	43.10	41.61	40.29	
11.8	6.52	60.21	53.07	50.01	47.55	45.50	43.77	42.25	40.92	
11.9	6.57	61.11	53.87	50.77	48.27	46.20	44.44	42.91	41.55	
12.0	6.63	62.02	54.68	51.54	49.01	46.90	45.12	43.56	42.19	

Uponor PEX friction loss tables

3/4" Uponor AquaPEX (100% water)

psi loss per 100 feet of tubing										
Velocity (ft/s)	gpm	40°F 4°C	60°F 16°C	80°F 27°C	100°F 38°C	120°F 49°C	140°F 60°C	160°F 71°C	180°F 82°C	
1.5	1.65	1.08	0.92	0.86	0.81	0.76	0.73	0.70	0.67	
1.6	1.76	1.21	1.03	0.96	0.90	0.85	0.81	0.78	0.75	
1.7	1.87	1.34	1.15	1.07	1.00	0.95	0.90	0.87	0.83	
1.8	1.98	1.48	1.27	1.18	1.11	1.05	1.00	0.96	0.92	
1.9	2.09	1.62	1.39	1.29	1.22	1.15	1.10	1.05	1.01	
2.0	2.20	1.77	1.52	1.41	1.33	1.26	1.20	1.15	1.11	
2.1	2.31	1.92	1.65	1.54	1.45	1.37	1.31	1.26	1.21	
2.2	2.43	2.08	1.79	1.67	1.57	1.49	1.42	1.37	1.31	
2.3	2.54	2.25	1.94	1.81	1.70	1.61	1.54	1.48	1.42	
2.4	2.65	2.42	2.09	1.94	1.83	1.74	1.66	1.59	1.53	
2.5	2.76	2.60	2.24	2.09	1.97	1.87	1.78	1.71	1.65	
2.6	2.87	2.78	2.40	2.24	2.11	2.00	1.91	1.83	1.77	
2.7	2.98	2.97	2.56	2.39	2.25	2.14	2.04	1.96	1.89	
2.8	3.09	3.16	2.73	2.55	2.40	2.28	2.18	2.09	2.02	
2.9	3.20	3.36	2.90	2.71	2.55	2.43	2.32	2.23	2.15	
3.0	3.31	3.56	3.08	2.88	2.71	2.58	2.46	2.37	2.28	
3.1	3.42	3.77	3.26	3.05	2.87	2.73	2.61	2.51	2.42	
3.2	3.53	3.98	3.45	3.22	3.04	2.89	2.76	2.65	2.56	
3.3	3.64	4.20	3.64	3.40	3.21	3.05	2.92	2.80	2.70	
3.4	3.75	4.42	3.83	3.58	3.38	3.22	3.08	2.95	2.85	
3.5	3.86	4.65	4.03	3.77	3.56	3.39	3.24	3.11	3.00	
3.6	3.97	4.88	4.24	3.96	3.74	3.56	3.40	3.27	3.15	
3.7	4.08	5.12	4.44	4.16	3.93	3.74	3.57	3.43	3.31	
3.8	4.19	5.36	4.66	4.36	4.12	3.92	3.75	3.60	3.47	
3.9	4.30	5.61	4.87	4.56	4.31	4.10	3.93	3.77	3.64	
4.0	4.41	5.86	5.10	4.77	4.51	4.29	4.11	3.95	3.81	
4.1	4.52	6.12	5.32	4.98	4.71	4.48	4.29	4.12	3.98	
4.2	4.63	6.38	5.55	5.20	4.91	4.68	4.48	4.31	4.15	
4.3	4.74	6.65	5.79	5.42	5.12	4.88	4.67	4.49	4.33	
4.4	4.85	6.92	6.02	5.64	5.34	5.08	4.87	4.68	4.51	
4.5	4.96	7.20	6.27	5.87	5.55	5.29	5.06	4.87	4.70	
4.6	5.07	7.48	6.51	6.10	5.77	5.50	5.27	5.07	4.89	
4.7	5.18	7.76	6.77	6.34	6.00	5.71	5.47	5.26	5.08	
4.8	5.29	8.05	7.02	6.58	6.23	5.93	5.68	5.47	5.27	
4.9	5.40	8.35	7.28	6.82	6.46	6.15	5.90	5.67	5.47	
5.0	5.51	8.65	7.54	7.07	6.69	6.38	6.11	5.88	5.68	
5.1	5.62	8.95	7.81	7.33	6.93	6.61	6.33	6.09	5.88	
5.2	5.73	9.26	8.08	7.58	7.18	6.84	6.56	6.31	6.09	
5.3	5.84	9.57	8.36	7.84	7.42	7.08	6.78	6.53	6.30	
5.4	5.95	9.89	8.64	8.11	7.67	7.32	7.01	6.75	6.52	
5.5	6.06	10.21	8.93	8.37	7.93	7.56	7.25	6.97	6.73	
5.6	6.17	10.54	9.21	8.65	8.19	7.81	7.48	7.20	6.96	
5.7	6.28	10.87	9.51	8.92	8.45	8.06	7.73	7.44	7.18	
5.8	6.39	11.21	9.80	9.20	8.71	8.31	7.97	7.67	7.41	
5.9	6.50	11.55	10.10	9.48	8.98	8.57	8.22	7.91	7.64	
6.0	6.61	11.89	10.41	9.77	9.26	8.83	8.47	8.15	7.87	
6.1	6.72	12.24	10.72	10.06	9.53	9.09	8.72	8.40	8.11	
6.2	6.83	12.60	11.03	10.36	9.81	9.36	8.98	8.65	8.35	
6.3	6.94	12.96	11.35	10.65	10.10	9.63	9.24	8.90	8.60	
6.4	7.05	13.32	11.67	10.96	10.38	9.91	9.51	9.15	8.84	
6.5	7.17	13.68	11.99	11.26	10.68	10.19	9.77	9.41	9.09	
6.6	7.28	14.06	12.32	11.57	10.97	10.47	10.05	9.67	9.35	
6.7	7.39	14.43	12.65	11.89	11.27	10.75	10.32	9.94	9.60	

3/4" Uponor AquaPEX (100% water)

psi loss per 100 feet of tubing										
Velocity (ft/s)	gpm	40°F 4°C	60°F 16°C	80°F 27°C	100°F 38°C	120°F 49°C	140°F 60°C	160°F 71°C	180°F 82°C	
6.8	7.50	14.81	12.99	12.20	11.57	11.04	10.60	10.21	9.86	
6.9	7.61	15.20	13.33	12.52	11.88	11.34	10.88	10.48	10.13	
7.0	7.72	15.59	13.67	12.85	12.18	11.63	11.16	10.75	10.39	
7.1	7.83	15.98	14.02	13.18	12.50	11.93	11.45	11.03	10.66	
7.2	7.94	16.38	14.37	13.51	12.81	12.23	11.74	11.31	10.93	
7.3	8.05	16.78	14.73	13.84	13.13	12.54	12.04	11.60	11.21	
7.4	8.16	17.18	15.09	14.18	13.46	12.85	12.34	11.89	11.49	
7.5	8.27	17.59	15.45	14.53	13.78	13.16	12.64	12.18	11.77	
7.6	8.38	18.01	15.82	14.87	14.11	13.48	12.94	12.47	12.06	
7.7	8.49	18.43	16.19	15.22	14.45	13.80	13.25	12.77	12.34	
7.8	8.60	18.85	16.56	15.58	14.78	14.12	13.56	13.07	12.63	
7.9	8.71	19.28	16.94	15.94	15.12	14.45	13.87	13.37	12.93	
8.0	8.82	19.71	17.32	16.30	15.47	14.78	14.19	13.68	13.23	
8.1	8.93	20.14	17.71	16.66	15.81	15.11	14.51	13.99	13.53	
8.2	9.04	20.58	18.10	17.03	16.17	15.45	14.84	14.30	13.83	
8.3	9.15	21.03	18.49	17.40	16.52	15.78	15.16	14.62	14.13	
8.4	9.26	21.48	18.89	17.78	16.88	16.13	15.49	14.94	14.44	
8.5	9.37	21.93	19.29	18.16	17.24	16.47	15.83	15.26	14.76	
8.6	9.48	22.38	19.70	18.54	17.60	16.82	16.16	15.58	15.07	
8.7	9.59	22.85	20.11	18.93	17.97	17.18	16.50	15.91	15.39	
8.8	9.70	23.31	20.52	19.32	18.34	17.53	16.85	16.24	15.71	
8.9	9.81	23.78	20.94	19.71	18.72	17.89	17.19	16.58	16.04	
9.0	9.92	24.25	21.36	20.11	19.10	18.26	17.54	16.92	16.36	
9.1	10.03	24.73	21.78	20.51	19.48	18.62	17.89	17.26	16.69	
9.2	10.14	25.21	22.21	20.91	19.86	18.99	18.25	17.60	17.03	
9.3	10.25	25.70	22.64	21.32	20.25	19.36	18.61	17.95	17.36	
9.4	10.36	26.18	23.07	21.73	20.65	19.74	18.97	18.30	17.70	
9.5	10.47	26.68	23.51	22.15	21.04	20.12	19.34	18.65	18.05	
9.6	10.58	27.18	23.95	22.56	21.44	20.50	19.71	19.01	18.39	
9.7	10.69	27.68	24.40	22.99	21.84	20.89	20.08	19.37	18.74	
9.8	10.80	28.18	24.85	23.41	22.25	21.28	20.45	19.73	19.09	
9.9	10.91	28.69	25.30	23.84	22.66	21.67	20.83	20.10	19.45	
10.0	11.02	29.21	25.76	24.27	23.07	22.06	21.21	20.46	19.80	
10.1	11.13	29.72	26.22	24.71	23.48	22.46	21.60	20.84	20.17	
10.2	11.24	30.25	26.68	25.15	23.90	22.86	21.98	21.21	20.53	
10.3	11.35	30.77	27.15	25.59	24.33	23.27	22.37	21.59	20.89	
10.4	11.46	31.30	27.62	26.04	24.75	23.68	22.77	21.97	21.26	
10.5	11.57	31.84	28.10	26.49	25.18	24.09	23.17	22.35	21.64	
10.6	11.68	32.37	28.58	26.94	25.61	24.50	23.57	22.74	22.01	
10.7	11.79	32.92	29.06	27.40	26.05	24.92	23.97	23.13	22.39	
10.8	11.91	33.46	29.55	27.86	26.49	25.34	24.37	23.52	22.77	
10.9	12.02	34.01	30.04	28.32	26.93	25.77	24.78	23.92	23.16	
11.0	12.13	34.57	30.53	28.79	27.37	26.20	25.20	24.32	23.54	
11.1	12.24	35.12	31.03	29.26	27.82	26.63	25.61	24.72	23.93	
11.2	12.35	35.68	31.53	29.73	28.28	27.06	26.03	25.13	24.33	
11.3	12.46	36.25	32.03	30.21	28.73	27.50	26.45	25.53	24.72	
11.4	12.57	36.82	32.54	30.69	29.19	27.94	26.88	25.94	25.12	
11.5	12.68	37.39	33.05	31.17	29.65	28.38	27.30	26.36	25.52	
11.6	12.79	37.97	33.56	31.66	30.12	28.83	27.74	26.78	25.93	
11.7	12.90	38.55	34.08	32.15	30.59	29.28	28.17	27.20	26.33	
11.8	13.01	39.14	34.60	32.64	31.06	29.73	28.61	27.62	26.75	
11.9	13.12	39.73	35.13	33.14	31.53	30.19	29.05	28.04	27.16	
12.0	13.23	40.32	35.66	33.64	32.01	30.65	29.49	28.47	27.58	

Uponor PEX friction loss tables

1" Uponor AquaPEX (100% water)

psi loss per 100 feet of tubing										
Velocity (ft/s)	gpm	40°F 4°C	60°F 16°C	80°F 27°C	100°F 38°C	120°F 49°C	140°F 60°C	160°F 71°C	180°F 82°C	
1.5	2.73	0.78	0.67	0.62	0.59	0.56	0.53	0.51	0.49	
1.6	2.91	0.87	0.75	0.70	0.66	0.62	0.59	0.57	0.55	
1.7	3.09	0.97	0.83	0.78	0.73	0.69	0.66	0.63	0.61	
1.8	3.27	1.07	0.92	0.86	0.81	0.77	0.73	0.70	0.68	
1.9	3.46	1.17	1.01	0.94	0.89	0.84	0.81	0.77	0.74	
2.0	3.64	1.28	1.11	1.03	0.97	0.92	0.88	0.85	0.81	
2.1	3.82	1.40	1.21	1.12	1.06	1.01	0.96	0.92	0.89	
2.2	4.00	1.51	1.31	1.22	1.15	1.09	1.04	1.00	0.96	
2.3	4.18	1.63	1.41	1.32	1.24	1.18	1.13	1.08	1.04	
2.4	4.37	1.76	1.52	1.42	1.34	1.27	1.22	1.17	1.13	
2.5	4.55	1.89	1.63	1.53	1.44	1.37	1.31	1.26	1.21	
2.6	4.73	2.02	1.75	1.64	1.54	1.47	1.40	1.35	1.30	
2.7	4.91	2.16	1.87	1.75	1.65	1.57	1.50	1.44	1.39	
2.8	5.09	2.30	1.99	1.86	1.76	1.67	1.60	1.54	1.48	
2.9	5.28	2.44	2.12	1.98	1.87	1.78	1.70	1.63	1.58	
3.0	5.46	2.59	2.25	2.10	1.99	1.89	1.81	1.74	1.67	
3.1	5.64	2.74	2.38	2.23	2.10	2.00	1.92	1.84	1.77	
3.2	5.82	2.90	2.52	2.36	2.23	2.12	2.03	1.95	1.88	
3.3	6.00	3.06	2.66	2.49	2.35	2.24	2.14	2.06	1.98	
3.4	6.19	3.22	2.80	2.62	2.48	2.36	2.26	2.17	2.09	
3.5	6.37	3.39	2.95	2.76	2.61	2.48	2.38	2.29	2.20	
3.6	6.55	3.56	3.10	2.90	2.74	2.61	2.50	2.40	2.32	
3.7	6.73	3.73	3.25	3.04	2.88	2.74	2.63	2.52	2.43	
3.8	6.91	3.91	3.41	3.19	3.02	2.87	2.75	2.65	2.55	
3.9	7.09	4.09	3.56	3.34	3.16	3.01	2.88	2.77	2.68	
4.0	7.28	4.27	3.73	3.49	3.31	3.15	3.02	2.90	2.80	
4.1	7.46	4.46	3.89	3.65	3.45	3.29	3.15	3.03	2.93	
4.2	7.64	4.65	4.06	3.81	3.60	3.43	3.29	3.17	3.06	
4.3	7.82	4.85	4.23	3.97	3.76	3.58	3.43	3.30	3.19	
4.4	8.00	5.05	4.41	4.14	3.92	3.73	3.58	3.44	3.32	
4.5	8.19	5.25	4.59	4.30	4.07	3.88	3.72	3.58	3.46	
4.6	8.37	5.46	4.77	4.47	4.24	4.04	3.87	3.73	3.60	
4.7	8.55	5.66	4.95	4.65	4.40	4.20	4.02	3.87	3.74	
4.8	8.73	5.88	5.14	4.83	4.57	4.36	4.18	4.02	3.88	
4.9	8.91	6.09	5.33	5.01	4.74	4.52	4.34	4.17	4.03	
5.0	9.10	6.31	5.53	5.19	4.91	4.69	4.49	4.33	4.18	
5.1	9.28	6.54	5.72	5.37	5.09	4.86	4.66	4.48	4.33	
5.2	9.46	6.76	5.92	5.56	5.27	5.03	4.82	4.64	4.48	
5.3	9.64	6.99	6.13	5.75	5.45	5.20	4.99	4.80	4.64	
5.4	9.82	7.22	6.33	5.95	5.64	5.38	5.16	4.97	4.80	
5.5	10.01	7.46	6.54	6.14	5.82	5.56	5.33	5.13	4.96	
5.6	10.19	7.70	6.75	6.34	6.01	5.74	5.51	5.30	5.12	
5.7	10.37	7.94	6.97	6.55	6.21	5.92	5.68	5.47	5.29	
5.8	10.55	8.19	7.19	6.75	6.40	6.11	5.86	5.65	5.46	
5.9	10.73	8.44	7.41	6.96	6.60	6.30	6.05	5.82	5.63	
6.0	10.92	8.69	7.63	7.17	6.80	6.49	6.23	6.00	5.80	
6.1	11.10	8.95	7.86	7.39	7.01	6.69	6.42	6.18	5.97	
6.2	11.28	9.21	8.09	7.60	7.21	6.89	6.61	6.37	6.15	
6.3	11.46	9.47	8.32	7.82	7.42	7.09	6.80	6.55	6.33	
6.4	11.64	9.74	8.56	8.05	7.63	7.29	7.00	6.74	6.51	
6.5	11.82	10.01	8.79	8.27	7.85	7.49	7.19	6.93	6.70	
6.6	12.01	10.28	9.04	8.50	8.06	7.70	7.39	7.12	6.89	
6.7	12.19	10.56	9.28	8.73	8.28	7.91	7.60	7.32	7.07	

1" Uponor AquaPEX (100% water)

psi loss per 100 feet of tubing										
Velocity (ft/s)	gpm	40°F 4°C	60°F 16°C	80°F 27°C	100°F 38°C	120°F 49°C	140°F 60°C	160°F 71°C	180°F 82°C	
6.8	12.37	10.83	9.53	8.96	8.51	8.12	7.80	7.52	7.27	
6.9	12.55	11.12	9.78	9.20	8.73	8.34	8.01	7.72	7.46	
7.0	12.73	11.40	10.03	9.44	8.96	8.56	8.22	7.92	7.66	
7.1	12.92	11.69	10.29	9.68	9.19	8.78	8.43	8.12	7.85	
7.2	13.10	11.98	10.55	9.92	9.42	9.00	8.65	8.33	8.06	
7.3	13.28	12.28	10.81	10.17	9.66	9.23	8.86	8.54	8.26	
7.4	13.46	12.57	11.07	10.42	9.89	9.45	9.08	8.75	8.46	
7.5	13.64	12.88	11.34	10.67	10.14	9.69	9.30	8.97	8.67	
7.6	13.83	13.18	11.61	10.93	10.38	9.92	9.53	9.19	8.88	
7.7	14.01	13.49	11.88	11.19	10.62	10.15	9.76	9.40	9.09	
7.8	14.19	13.80	12.16	11.45	10.87	10.39	9.98	9.63	9.31	
7.9	14.37	14.11	12.44	11.71	11.12	10.63	10.22	9.85	9.53	
8.0	14.55	14.43	12.72	11.98	11.38	10.88	10.45	10.08	9.74	
8.1	14.74	14.75	13.00	12.25	11.63	11.12	10.69	10.30	9.97	
8.2	14.92	15.07	13.29	12.52	11.89	11.37	10.93	10.54	10.19	
8.3	15.10	15.40	13.58	12.79	12.15	11.62	11.17	10.77	10.42	
8.4	15.28	15.73	13.87	13.07	12.42	11.87	11.41	11.00	10.64	
8.5	15.46	16.06	14.17	13.35	12.68	12.13	11.66	11.24	10.87	
8.6	15.64	16.39	14.47	13.63	12.95	12.39	11.90	11.48	11.11	
8.7	15.83	16.73	14.77	13.91	13.22	12.65	12.16	11.72	11.34	
8.8	16.01	17.07	15.07	14.20	13.50	12.91	12.41	11.97	11.58	
8.9	16.19	17.42	15.38	14.49	13.77	13.17	12.66	12.22	11.82	
9.0	16.37	17.77	15.69	14.78	14.05	13.44	12.92	12.46	12.06	
9.1	16.55	18.12	16.00	15.08	14.33	13.71	13.18	12.72	12.30	
9.2	16.74	18.47	16.31	15.38	14.62	13.98	13.44	12.97	12.55	
9.3	16.92	18.83	16.63	15.68	14.91	14.26	13.71	13.23	12.80	
9.4	17.10	19.19	16.95	15.98	15.19	14.54	13.98	13.48	13.05	
9.5	17.28	19.55	17.27	16.29	15.49	14.82	14.25	13.74	13.30	
9.6	17.46	19.92	17.60	16.60	15.78	15.10	14.52	14.01	13.56	
9.7	17.65	20.28	17.93	16.91	16.08	15.38	14.79	14.27	13.81	
9.8	17.83	20.66	18.26	17.22	16.38	15.67	15.07	14.54	14.07	
9.9	18.01	21.03	18.59	17.54	16.68	15.96	15.35	14.81	14.33	
10.0	18.19	21.41	18.93	17.85	16.98	16.25	15.63	15.08	14.60	
10.1	18.37	21.79	19.27	18.18	17.29	16.54	15.91	15.36	14.86	
10.2	18.56	22.17	19.61	18.50	17.60	16.84	16.20	15.63	15.13	
10.3	18.74	22.56	19.96	18.83	17.91	17.14	16.49	15.91	15.40	
10.4	18.92	22.95	20.30	19.15	18.22	17.44	16.78	16.19	15.67	
10.5	19.10	23.34	20.65	19.49	18.54	17.74	17.07	16.47	15.95	
10.6	19.28	23.74	21.01	19.82	18.86	18.05	17.36	16.76	16.23	
10.7	19.47	24.14	21.36	20.16	19.18	18.36	17.66	17.05	16.50	
10.8	19.65	24.54	21.72	20.50	19.50	18.67	17.96	17.34	16.79	
10.9	19.83	24.94	22.08	20.84	19.83	18.98	18.26	17.63	17.07	
11.0	20.01	25.35	22.44	21.18	20.16	19.30	18.57	17.92	17.35	
11.1	20.19	25.76	22.81	21.53	20.49	19.61	18.87	18.22	17.64	
11.2	20.37	26.17	23.18	21.88	20.82	19.93	19.18	18.52	17.93	
11.3	20.56	26.59	23.55	22.23	21.16	20.26	19.49	18.82	18.22	
11.4	20.74	27.01	23.92	22.58	21.49	20.58	19.81	19.12	18.52	
11.5	20.92	27.43	24.30	22.94	21.84	20.91	20.12	19.43	18.81	
11.6	21.10	27.85	24.68	23.30	22.18	21.24	20.44	19.74	19.11	
11.7	21.28	28.28	25.06	23.66	22.52	21.57	20.76	20.05	19.41	
11.8	21.47	28.71	25.45	24.03	22.87	21.90	21.08	20.36	19.72	
11.9	21.65	29.14	25.83	24.39	23.22	22.24	21.41	20.67	20.02	
12.0	21.83	29.58	26.22	24.76	23.58	22.58	21.73	20.99	20.33	

Uponor PEX friction loss tables

1¼" Uponor AquaPEX (100% water)

psi loss per 100 feet of tubing										
Velocity (ft/s)	gpm	40°F 4°C	60°F 16°C	80°F 27°C	100°F 38°C	120°F 49°C	140°F 60°C	160°F 71°C	180°F 82°C	
1.5	4.08	0.60	0.52	0.49	0.46	0.43	0.41	0.40	0.38	
1.6	4.35	0.68	0.58	0.54	0.51	0.49	0.46	0.44	0.43	
1.7	4.62	0.75	0.65	0.60	0.57	0.54	0.52	0.49	0.48	
1.8	4.90	0.83	0.72	0.67	0.63	0.60	0.57	0.55	0.53	
1.9	5.17	0.91	0.79	0.73	0.69	0.66	0.63	0.60	0.58	
2.0	5.44	0.99	0.86	0.80	0.76	0.72	0.69	0.66	0.64	
2.1	5.71	1.08	0.94	0.87	0.82	0.78	0.75	0.72	0.69	
2.2	5.98	1.17	1.02	0.95	0.90	0.85	0.81	0.78	0.75	
2.3	6.26	1.27	1.10	1.03	0.97	0.92	0.88	0.85	0.81	
2.4	6.53	1.36	1.18	1.11	1.04	0.99	0.95	0.91	0.88	
2.5	6.80	1.46	1.27	1.19	1.12	1.07	1.02	0.98	0.95	
2.6	7.07	1.57	1.36	1.27	1.20	1.14	1.09	1.05	1.01	
2.7	7.34	1.67	1.45	1.36	1.29	1.22	1.17	1.12	1.08	
2.8	7.62	1.78	1.55	1.45	1.37	1.30	1.25	1.20	1.16	
2.9	7.89	1.89	1.65	1.54	1.46	1.39	1.33	1.28	1.23	
3.0	8.16	2.01	1.75	1.64	1.55	1.47	1.41	1.36	1.31	
3.1	8.43	2.13	1.85	1.74	1.64	1.56	1.50	1.44	1.39	
3.2	8.70	2.25	1.96	1.84	1.74	1.65	1.58	1.52	1.47	
3.3	8.98	2.37	2.07	1.94	1.83	1.75	1.67	1.61	1.55	
3.4	9.25	2.50	2.18	2.04	1.93	1.84	1.76	1.70	1.64	
3.5	9.52	2.63	2.29	2.15	2.04	1.94	1.86	1.79	1.72	
3.6	9.79	2.76	2.41	2.26	2.14	2.04	1.95	1.88	1.81	
3.7	10.06	2.90	2.53	2.37	2.25	2.14	2.05	1.97	1.90	
3.8	10.34	3.03	2.65	2.49	2.36	2.25	2.15	2.07	2.00	
3.9	10.61	3.18	2.78	2.61	2.47	2.35	2.25	2.17	2.09	
4.0	10.88	3.32	2.90	2.73	2.58	2.46	2.36	2.27	2.19	
4.1	11.15	3.47	3.03	2.85	2.70	2.57	2.47	2.37	2.29	
4.2	11.42	3.62	3.17	2.97	2.81	2.68	2.57	2.48	2.39	
4.3	11.70	3.77	3.30	3.10	2.94	2.80	2.68	2.58	2.49	
4.4	11.97	3.92	3.44	3.23	3.06	2.92	2.80	2.69	2.60	
4.5	12.24	4.08	3.58	3.36	3.18	3.04	2.91	2.80	2.71	
4.6	12.51	4.24	3.72	3.49	3.31	3.16	3.03	2.92	2.82	
4.7	12.78	4.40	3.86	3.63	3.44	3.28	3.15	3.03	2.93	
4.8	13.06	4.57	4.01	3.77	3.57	3.41	3.27	3.15	3.04	
4.9	13.33	4.74	4.16	3.91	3.70	3.54	3.39	3.27	3.15	
5.0	13.60	4.91	4.31	4.05	3.84	3.67	3.52	3.39	3.27	
5.1	13.87	5.08	4.46	4.20	3.98	3.80	3.64	3.51	3.39	
5.2	14.14	5.26	4.62	4.34	4.12	3.93	3.77	3.63	3.51	
5.3	14.42	5.44	4.78	4.49	4.26	4.07	3.90	3.76	3.63	
5.4	14.69	5.62	4.94	4.64	4.41	4.21	4.04	3.89	3.76	
5.5	14.96	5.81	5.10	4.80	4.55	4.35	4.17	4.02	3.88	
5.6	15.23	5.99	5.27	4.96	4.70	4.49	4.31	4.15	4.01	
5.7	15.50	6.18	5.44	5.11	4.85	4.63	4.45	4.29	4.14	
5.8	15.78	6.38	5.61	5.27	5.01	4.78	4.59	4.42	4.27	
5.9	16.05	6.57	5.78	5.44	5.16	4.93	4.73	4.56	4.41	
6.0	16.32	6.77	5.96	5.60	5.32	5.08	4.88	4.70	4.54	
6.1	16.59	6.97	6.13	5.77	5.48	5.23	5.02	4.84	4.68	
6.2	16.86	7.17	6.31	5.94	5.64	5.39	5.17	4.99	4.82	
6.3	17.13	7.38	6.49	6.11	5.80	5.54	5.32	5.13	4.96	
6.4	17.41	7.58	6.68	6.29	5.97	5.70	5.48	5.28	5.10	
6.5	17.68	7.79	6.87	6.46	6.14	5.86	5.63	5.43	5.25	
6.6	17.95	8.01	7.05	6.64	6.31	6.03	5.79	5.58	5.39	
6.7	18.22	8.22	7.25	6.82	6.48	6.19	5.95	5.73	5.54	

1" Uponor AquaPEX (100% water)

psi loss per 100 feet of tubing										
Velocity (ft/s)	gpm	40°F 4°C	60°F 16°C	80°F 27°C	100°F 38°C	120°F 49°C	140°F 60°C	160°F 71°C	180°F 82°C	
6.8	18.49	8.44	7.44	7.01	6.65	6.36	6.11	5.89	5.69	
6.9	18.77	8.66	7.64	7.19	6.83	6.53	6.27	6.05	5.85	
7.0	19.04	8.88	7.83	7.38	7.01	6.70	6.44	6.20	6.00	
7.1	19.31	9.11	8.03	7.57	7.19	6.87	6.60	6.37	6.16	
7.2	19.58	9.34	8.24	7.76	7.37	7.05	6.77	6.53	6.31	
7.3	19.85	9.57	8.44	7.95	7.56	7.22	6.94	6.69	6.47	
7.4	20.13	9.80	8.65	8.15	7.74	7.40	7.11	6.86	6.63	
7.5	20.40	10.04	8.86	8.35	7.93	7.58	7.29	7.03	6.80	
7.6	20.67	10.27	9.07	8.55	8.12	7.77	7.46	7.20	6.96	
7.7	20.94	10.51	9.28	8.75	8.31	7.95	7.64	7.37	7.13	
7.8	21.21	10.76	9.50	8.95	8.51	8.14	7.82	7.54	7.30	
7.9	21.49	11.00	9.72	9.16	8.71	8.33	8.00	7.72	7.47	
8.0	21.76	11.25	9.94	9.37	8.90	8.52	8.19	7.90	7.64	
8.1	22.03	11.50	10.16	9.58	9.10	8.71	8.37	8.07	7.81	
8.2	22.30	11.75	10.38	9.79	9.31	8.90	8.56	8.26	7.99	
8.3	22.57	12.01	10.61	10.01	9.51	9.10	8.75	8.44	8.16	
8.4	22.85	12.26	10.84	10.22	9.72	9.30	8.94	8.62	8.34	
8.5	23.12	12.52	11.07	10.44	9.93	9.50	9.13	8.81	8.52	
8.6	23.39	12.79	11.31	10.66	10.14	9.70	9.33	9.00	8.71	
8.7	23.66	13.05	11.54	10.89	10.35	9.90	9.52	9.19	8.89	
8.8	23.93	13.32	11.78	11.11	10.57	10.11	9.72	9.38	9.08	
8.9	24.21	13.59	12.02	11.34	10.78	10.32	9.92	9.57	9.27	
9.0	24.48	13.86	12.26	11.57	11.00	10.53	10.12	9.77	9.45	
9.1	24.75	14.13	12.51	11.80	11.22	10.74	10.33	9.97	9.65	
9.2	25.02	14.41	12.75	12.03	11.45	10.95	10.53	10.17	9.84	
9.3	25.29	14.69	13.00	12.27	11.67	11.17	10.74	10.37	10.03	
9.4	25.57	14.97	13.25	12.50	11.90	11.39	10.95	10.57	10.23	
9.5	25.84	15.25	13.50	12.74	12.13	11.61	11.16	10.77	10.43	
9.6	26.11	15.54	13.76	12.99	12.36	11.83	11.38	10.98	10.63	
9.7	26.38	15.83	14.02	13.23	12.59	12.05	11.59	11.19	10.83	
9.8	26.65	16.12	14.28	13.48	12.82	12.28	11.81	11.40	11.03	
9.9	26.93	16.41	14.54	13.72	13.06	12.50	12.03	11.61	11.24	
10.0	27.20	16.71	14.80	13.97	13.30	12.73	12.25	11.82	11.45	
10.1	27.47	17.00	15.07	14.22	13.54	12.96	12.47	12.04	11.65	
10.2	27.74	17.30	15.34	14.48	13.78	13.19	12.70	12.26	11.87	
10.3	28.01	17.61	15.61	14.73	14.02	13.43	12.92	12.47	12.08	
10.4	28.29	17.91	15.88	14.99	14.27	13.66	13.15	12.69	12.29	
10.5	28.56	18.22	16.15	15.25	14.52	13.90	13.38	12.92	12.51	
10.6	28.83	18.53	16.43	15.51	14.77	14.14	13.61	13.14	12.72	
10.7	29.10	18.84	16.71	15.78	15.02	14.38	13.84	13.37	12.94	
10.8	29.37	19.15	16.99	16.04	15.27	14.63	14.08	13.59	13.16	
10.9	29.65	19.47	17.27	16.31	15.53	14.87	14.32	13.82	13.39	
11.0	29.92	19.79	17.55	16.58	15.79	15.12	14.55	14.05	13.61	
11.1	30.19	20.11	17.84	16.85	16.05	15.37	14.79	14.29	13.84	
11.2	30.46	20.43	18.13	17.13	16.31	15.62	15.04	14.52	14.06	
11.3	30.73	20.76	18.42	17.40	16.57	15.87	15.28	14.76	14.29	
11.4	31.01	21.09	18.71	17.68	16.84	16.13	15.53	14.99	14.52	
11.5	31.28	21.42	19.01	17.96	17.10	16.39	15.77	15.23	14.75	
11.6	31.55	21.75	19.31	18.24	17.37	16.64	16.02	15.48	14.99	
11.7	31.82	22.08	19.61	18.53	17.64	16.91	16.27	15.72	15.22	
11.8	32.09	22.42	19.91	18.81	17.92	17.17	16.53	15.96	15.46	
11.9	32.37	22.76	20.21	19.10	18.19	17.43	16.78	16.21	15.70	
12.0	32.64	23.10	20.52	19.39	18.47	17.70	17.04	16.46	15.94	

Uponor PEX friction loss tables

1½" Uponor AquaPEX (100% water)

psi loss per 100 feet of tubing										
Velocity (ft/s)	gpm	40°F 4°C	60°F 16°C	80°F 27°C	100°F 38°C	120°F 49°C	140°F 60°C	160°F 71°C	180°F 82°C	
1.5	5.68	0.49	0.42	0.39	0.37	0.35	0.34	0.32	0.31	
1.6	6.06	0.55	0.47	0.44	0.42	0.40	0.38	0.36	0.35	
1.7	6.44	0.61	0.53	0.49	0.46	0.44	0.42	0.40	0.39	
1.8	6.82	0.67	0.58	0.54	0.51	0.49	0.46	0.45	0.43	
1.9	7.20	0.74	0.64	0.60	0.56	0.54	0.51	0.49	0.47	
2.0	7.58	0.80	0.70	0.65	0.62	0.59	0.56	0.54	0.52	
2.1	7.96	0.88	0.76	0.71	0.67	0.64	0.61	0.59	0.57	
2.2	8.34	0.95	0.83	0.77	0.73	0.69	0.66	0.64	0.61	
2.3	8.71	1.03	0.89	0.83	0.79	0.75	0.72	0.69	0.67	
2.4	9.09	1.10	0.96	0.90	0.85	0.81	0.77	0.74	0.72	
2.5	9.47	1.19	1.03	0.97	0.91	0.87	0.83	0.80	0.77	
2.6	9.85	1.27	1.11	1.04	0.98	0.93	0.89	0.86	0.83	
2.7	10.23	1.36	1.18	1.11	1.05	1.00	0.96	0.92	0.89	
2.8	10.61	1.45	1.26	1.18	1.12	1.06	1.02	0.98	0.95	
2.9	10.99	1.54	1.34	1.26	1.19	1.13	1.08	1.04	1.01	
3.0	11.37	1.63	1.42	1.33	1.26	1.20	1.15	1.11	1.07	
3.1	11.75	1.73	1.51	1.41	1.34	1.28	1.22	1.18	1.13	
3.2	12.12	1.83	1.60	1.50	1.42	1.35	1.29	1.24	1.20	
3.3	12.50	1.93	1.68	1.58	1.50	1.43	1.37	1.31	1.27	
3.4	12.88	2.03	1.78	1.67	1.58	1.50	1.44	1.39	1.34	
3.5	13.26	2.14	1.87	1.75	1.66	1.58	1.52	1.46	1.41	
3.6	13.64	2.24	1.96	1.84	1.75	1.66	1.60	1.54	1.48	
3.7	14.02	2.35	2.06	1.94	1.83	1.75	1.68	1.61	1.56	
3.8	14.40	2.47	2.16	2.03	1.92	1.83	1.76	1.69	1.63	
3.9	14.78	2.58	2.26	2.12	2.01	1.92	1.84	1.77	1.71	
4.0	15.16	2.70	2.37	2.22	2.11	2.01	1.93	1.85	1.79	
4.1	15.53	2.82	2.47	2.32	2.20	2.10	2.01	1.94	1.87	
4.2	15.91	2.94	2.58	2.42	2.30	2.19	2.10	2.02	1.96	
4.3	16.29	3.06	2.69	2.53	2.40	2.29	2.19	2.11	2.04	
4.4	16.67	3.19	2.80	2.63	2.50	2.38	2.29	2.20	2.13	
4.5	17.05	3.32	2.91	2.74	2.60	2.48	2.38	2.29	2.21	
4.6	17.43	3.45	3.03	2.85	2.70	2.58	2.48	2.38	2.30	
4.7	17.81	3.58	3.15	2.96	2.81	2.68	2.57	2.48	2.39	
4.8	18.19	3.72	3.27	3.07	2.92	2.78	2.67	2.57	2.49	
4.9	18.57	3.86	3.39	3.19	3.03	2.89	2.77	2.67	2.58	
5.0	18.94	4.00	3.51	3.31	3.14	2.99	2.87	2.77	2.68	
5.1	19.32	4.14	3.64	3.42	3.25	3.10	2.98	2.87	2.77	
5.2	19.70	4.28	3.77	3.54	3.36	3.21	3.08	2.97	2.87	
5.3	20.08	4.43	3.90	3.67	3.48	3.32	3.19	3.08	2.97	
5.4	20.46	4.58	4.03	3.79	3.60	3.44	3.30	3.18	3.07	
5.5	20.84	4.73	4.16	3.92	3.72	3.55	3.41	3.29	3.18	
5.6	21.22	4.88	4.30	4.05	3.84	3.67	3.52	3.40	3.28	
5.7	21.60	5.03	4.44	4.18	3.96	3.79	3.64	3.51	3.39	
5.8	21.98	5.19	4.57	4.31	4.09	3.91	3.75	3.62	3.50	
5.9	22.35	5.35	4.72	4.44	4.22	4.03	3.87	3.73	3.61	
6.0	22.73	5.51	4.86	4.58	4.35	4.15	3.99	3.85	3.72	
6.1	23.11	5.67	5.00	4.71	4.48	4.28	4.11	3.96	3.83	
6.2	23.49	5.84	5.15	4.85	4.61	4.41	4.23	4.08	3.94	
6.3	23.87	6.01	5.30	4.99	4.74	4.53	4.36	4.20	4.06	
6.4	24.25	6.18	5.45	5.13	4.88	4.66	4.48	4.32	4.18	
6.5	24.63	6.35	5.60	5.28	5.02	4.80	4.61	4.44	4.30	
6.6	25.01	6.52	5.76	5.43	5.16	4.93	4.74	4.57	4.42	
6.7	25.38	6.70	5.91	5.57	5.30	5.06	4.87	4.69	4.54	

1½" Uponor AquaPEX (100% water)

psi loss per 100 feet of tubing										
Velocity (ft/s)	gpm	40°F 4°C	60°F 16°C	80°F 27°C	100°F 38°C	120°F 49°C	140°F 60°C	160°F 71°C	180°F 82°C	
6.8	25.76	6.88	6.07	5.72	5.44	5.20	5.00	4.82	4.66	
6.9	26.14	7.06	6.23	5.87	5.58	5.34	5.13	4.95	4.79	
7.0	26.52	7.24	6.39	6.03	5.73	5.48	5.27	5.08	4.91	
7.1	26.90	7.42	6.56	6.18	5.88	5.62	5.40	5.21	5.04	
7.2	27.28	7.61	6.72	6.34	6.03	5.76	5.54	5.34	5.17	
7.3	27.66	7.80	6.89	6.50	6.18	5.91	5.68	5.48	5.30	
7.4	28.04	7.99	7.06	6.66	6.33	6.05	5.82	5.61	5.43	
7.5	28.42	8.18	7.23	6.82	6.48	6.20	5.96	5.75	5.56	
7.6	28.79	8.37	7.40	6.98	6.64	6.35	6.11	5.89	5.70	
7.7	29.17	8.57	7.58	7.15	6.80	6.50	6.25	6.03	5.84	
7.8	29.55	8.77	7.76	7.32	6.96	6.66	6.40	6.17	5.97	
7.9	29.93	8.97	7.93	7.48	7.12	6.81	6.55	6.32	6.11	
8.0	30.31	9.17	8.12	7.66	7.28	6.97	6.70	6.46	6.25	
8.1	30.69	9.37	8.30	7.83	7.45	7.13	6.85	6.61	6.40	
8.2	31.07	9.58	8.48	8.00	7.61	7.28	7.01	6.76	6.54	
8.3	31.45	9.79	8.67	8.18	7.78	7.45	7.16	6.91	6.69	
8.4	31.83	10.00	8.85	8.36	7.95	7.61	7.32	7.06	6.83	
8.5	32.20	10.21	9.04	8.53	8.12	7.77	7.48	7.21	6.98	
8.6	32.58	10.42	9.23	8.72	8.29	7.94	7.63	7.37	7.13	
8.7	32.96	10.64	9.43	8.90	8.47	8.10	7.80	7.52	7.28	
8.8	33.34	10.86	9.62	9.08	8.64	8.27	7.96	7.68	7.43	
8.9	33.72	11.08	9.82	9.27	8.82	8.44	8.12	7.84	7.59	
9.0	34.10	11.30	10.02	9.46	9.00	8.62	8.29	8.00	7.74	
9.1	34.48	11.53	10.22	9.65	9.18	8.79	8.46	8.16	7.90	
9.2	34.86	11.75	10.42	9.84	9.36	8.96	8.62	8.32	8.06	
9.3	35.24	11.98	10.62	10.03	9.55	9.14	8.79	8.49	8.22	
9.4	35.61	12.21	10.83	10.22	9.73	9.32	8.97	8.66	8.38	
9.5	35.99	12.44	11.03	10.42	9.92	9.50	9.14	8.82	8.54	
9.6	36.37	12.67	11.24	10.62	10.11	9.68	9.31	8.99	8.71	
9.7	36.75	12.91	11.45	10.82	10.30	9.86	9.49	9.16	8.87	
9.8	37.13	13.15	11.67	11.02	10.49	10.05	9.67	9.33	9.04	
9.9	37.51	13.39	11.88	11.22	10.68	10.23	9.85	9.51	9.21	
10.0	37.89	13.63	12.10	11.43	10.88	10.42	10.03	9.68	9.38	
10.1	38.27	13.87	12.31	11.63	11.08	10.61	10.21	9.86	9.55	
10.2	38.65	14.12	12.53	11.84	11.28	10.80	10.39	10.04	9.72	
10.3	39.02	14.36	12.75	12.05	11.48	10.99	10.58	10.22	9.89	
10.4	39.40	14.61	12.98	12.26	11.68	11.19	10.77	10.40	10.07	
10.5	39.78	14.86	13.20	12.47	11.88	11.38	10.96	10.58	10.25	
10.6	40.16	15.12	13.43	12.69	12.08	11.58	11.14	10.76	10.42	
10.7	40.54	15.37	13.65	12.90	12.29	11.78	11.34	10.95	10.60	
10.8	40.92	15.63	13.88	13.12	12.50	11.98	11.53	11.13	10.78	
10.9	41.30	15.89	14.12	13.34	12.71	12.18	11.72	11.32	10.97	
11.0	41.68	16.15	14.35	13.56	12.92	12.38	11.92	11.51	11.15	
11.1	42.06	16.41	14.58	13.78	13.13	12.58	12.12	11.70	11.33	
11.2	42.43	16.67	14.82	14.01	13.35	12.79	12.31	11.89	11.52	
11.3	42.81	16.94	15.06	14.24	13.56	13.00	12.51	12.09	11.71	
11.4	43.19	17.21	15.30	14.46	13.78	13.21	12.72	12.28	11.90	
11.5	43.57	17.48	15.54	14.69	14.00	13.42	12.92	12.48	12.09	
11.6	43.95	17.75	15.78	14.92	14.22	13.63	13.12	12.68	12.28	
11.7	44.33	18.02	16.03	15.16	14.44	13.84	13.33	12.88	12.47	
11.8	44.71	18.30	16.28	15.39	14.67	14.06	13.54	13.08	12.67	
11.9	45.09	18.58	16.52	15.62	14.89	14.27	13.75	13.28	12.86	
12.0	45.47	18.86	16.77	15.86	15.12	14.49	13.96	13.48	13.06	

Uponor PEX friction loss tables

2" Uponor AquaPEX (100% water)

psi loss per 100 feet of tubing										
Velocity (ft/s)	gpm	40°F 4°C	60°F 16°C	80°F 27°C	100°F 38°C	120°F 49°C	140°F 60°C	160°F 71°C	180°F 82°C	
1.5	9.75	0.35	0.30	0.28	0.27	0.25	0.24	0.23	0.22	
1.6	10.39	0.39	0.34	0.32	0.30	0.28	0.27	0.26	0.25	
1.7	11.04	0.43	0.38	0.35	0.33	0.32	0.30	0.29	0.28	
1.8	11.69	0.48	0.41	0.39	0.37	0.35	0.33	0.32	0.31	
1.9	12.34	0.52	0.46	0.43	0.40	0.38	0.37	0.35	0.34	
2.0	12.99	0.57	0.50	0.47	0.44	0.42	0.40	0.39	0.37	
2.1	13.64	0.62	0.54	0.51	0.48	0.46	0.44	0.42	0.41	
2.2	14.29	0.68	0.59	0.55	0.52	0.50	0.48	0.46	0.44	
2.3	14.94	0.73	0.64	0.60	0.57	0.54	0.52	0.50	0.48	
2.4	15.59	0.79	0.69	0.64	0.61	0.58	0.56	0.54	0.52	
2.5	16.24	0.85	0.74	0.69	0.66	0.63	0.60	0.58	0.56	
2.6	16.89	0.91	0.79	0.74	0.70	0.67	0.64	0.62	0.60	
2.7	17.54	0.97	0.85	0.79	0.75	0.72	0.69	0.66	0.64	
2.8	18.19	1.03	0.90	0.85	0.80	0.77	0.73	0.71	0.68	
2.9	18.84	1.10	0.96	0.90	0.85	0.81	0.78	0.75	0.73	
3.0	19.49	1.16	1.02	0.96	0.91	0.87	0.83	0.80	0.77	
3.1	20.14	1.23	1.08	1.02	0.96	0.92	0.88	0.85	0.82	
3.2	20.79	1.30	1.14	1.07	1.02	0.97	0.93	0.90	0.87	
3.3	21.44	1.38	1.21	1.13	1.08	1.03	0.98	0.95	0.91	
3.4	22.09	1.45	1.27	1.20	1.13	1.08	1.04	1.00	0.97	
3.5	22.74	1.53	1.34	1.26	1.19	1.14	1.09	1.05	1.02	
3.6	23.39	1.60	1.41	1.32	1.26	1.20	1.15	1.11	1.07	
3.7	24.04	1.68	1.48	1.39	1.32	1.26	1.21	1.16	1.12	
3.8	24.69	1.76	1.55	1.46	1.38	1.32	1.27	1.22	1.18	
3.9	25.34	1.85	1.62	1.53	1.45	1.38	1.33	1.28	1.24	
4.0	25.99	1.93	1.70	1.60	1.52	1.45	1.39	1.34	1.29	
4.1	26.64	2.02	1.77	1.67	1.58	1.51	1.45	1.40	1.35	
4.2	27.29	2.10	1.85	1.74	1.65	1.58	1.52	1.46	1.41	
4.3	27.94	2.19	1.93	1.82	1.72	1.65	1.58	1.52	1.47	
4.4	28.59	2.28	2.01	1.89	1.80	1.72	1.65	1.59	1.54	
4.5	29.24	2.38	2.09	1.97	1.87	1.79	1.72	1.65	1.60	
4.6	29.89	2.47	2.18	2.05	1.95	1.86	1.79	1.72	1.66	
4.7	30.54	2.57	2.26	2.13	2.02	1.93	1.86	1.79	1.73	
4.8	31.18	2.66	2.35	2.21	2.10	2.01	1.93	1.86	1.80	
4.9	31.83	2.76	2.44	2.29	2.18	2.08	2.00	1.93	1.86	
5.0	32.48	2.86	2.53	2.38	2.26	2.16	2.07	2.00	1.93	
5.1	33.13	2.96	2.62	2.46	2.34	2.24	2.15	2.07	2.00	
5.2	33.78	3.07	2.71	2.55	2.42	2.32	2.23	2.15	2.08	
5.3	34.43	3.17	2.80	2.64	2.51	2.40	2.30	2.22	2.15	
5.4	35.08	3.28	2.90	2.73	2.59	2.48	2.38	2.30	2.22	
5.5	35.73	3.39	2.99	2.82	2.68	2.56	2.46	2.37	2.30	
5.6	36.38	3.50	3.09	2.91	2.77	2.65	2.54	2.45	2.37	
5.7	37.03	3.61	3.19	3.01	2.86	2.73	2.63	2.53	2.45	
5.8	37.68	3.72	3.29	3.10	2.95	2.82	2.71	2.61	2.53	
5.9	38.33	3.84	3.39	3.20	3.04	2.91	2.80	2.70	2.61	
6.0	38.98	3.95	3.49	3.30	3.13	3.00	2.88	2.78	2.69	
6.1	39.63	4.07	3.60	3.39	3.23	3.09	2.97	2.86	2.77	
6.2	40.28	4.19	3.71	3.50	3.32	3.18	3.06	2.95	2.85	
6.3	40.93	4.31	3.81	3.60	3.42	3.27	3.15	3.03	2.94	
6.4	41.58	4.43	3.92	3.70	3.52	3.37	3.24	3.12	3.02	
6.5	42.23	4.55	4.03	3.80	3.62	3.46	3.33	3.21	3.11	
6.6	42.88	4.68	4.14	3.91	3.72	3.56	3.42	3.30	3.19	
6.7	43.53	4.81	4.26	4.02	3.82	3.66	3.52	3.39	3.28	

2" Uponor AquaPEX (100% water)

psi loss per 100 feet of tubing										
Velocity (ft/s)	gpm	40°F 4°C	60°F 16°C	80°F 27°C	100°F 38°C	120°F 49°C	140°F 60°C	160°F 71°C	180°F 82°C	
6.8	44.18	4.93	4.37	4.12	3.92	3.75	3.61	3.48	3.37	
6.9	44.83	5.06	4.49	4.23	4.03	3.86	3.71	3.58	3.46	
7.0	45.48	5.19	4.60	4.34	4.13	3.96	3.81	3.67	3.55	
7.1	46.13	5.33	4.72	4.46	4.24	4.06	3.90	3.77	3.65	
7.2	46.78	5.46	4.84	4.57	4.35	4.16	4.00	3.86	3.74	
7.3	47.43	5.60	4.96	4.68	4.46	4.27	4.10	3.96	3.83	
7.4	48.08	5.73	5.08	4.80	4.57	4.37	4.21	4.06	3.93	
7.5	48.73	5.87	5.21	4.92	4.68	4.48	4.31	4.16	4.03	
7.6	49.38	6.01	5.33	5.04	4.79	4.59	4.41	4.26	4.12	
7.7	50.03	6.15	5.46	5.16	4.91	4.70	4.52	4.36	4.22	
7.8	50.68	6.30	5.59	5.28	5.02	4.81	4.63	4.47	4.32	
7.9	51.33	6.44	5.72	5.40	5.14	4.92	4.73	4.57	4.42	
8.0	51.97	6.59	5.85	5.52	5.26	5.03	4.84	4.68	4.53	
8.1	52.62	6.73	5.98	5.65	5.38	5.15	4.95	4.78	4.63	
8.2	53.27	6.88	6.11	5.77	5.50	5.26	5.06	4.89	4.73	
8.3	53.92	7.03	6.24	5.90	5.62	5.38	5.18	5.00	4.84	
8.4	54.57	7.18	6.38	6.03	5.74	5.50	5.29	5.11	4.95	
8.5	55.22	7.34	6.52	6.16	5.86	5.62	5.41	5.22	5.05	
8.6	55.87	7.49	6.65	6.29	5.99	5.74	5.52	5.33	5.16	
8.7	56.52	7.65	6.79	6.42	6.11	5.86	5.64	5.44	5.27	
8.8	57.17	7.80	6.93	6.55	6.24	5.98	5.76	5.56	5.38	
8.9	57.82	7.96	7.08	6.69	6.37	6.10	5.87	5.67	5.49	
9.0	58.47	8.12	7.22	6.82	6.50	6.23	5.99	5.79	5.61	
9.1	59.12	8.28	7.36	6.96	6.63	6.35	6.12	5.91	5.72	
9.2	59.77	8.45	7.51	7.10	6.76	6.48	6.24	6.02	5.83	
9.3	60.42	8.61	7.66	7.24	6.90	6.61	6.36	6.14	5.95	
9.4	61.07	8.78	7.81	7.38	7.03	6.74	6.49	6.26	6.07	
9.5	61.72	8.94	7.95	7.52	7.17	6.87	6.61	6.39	6.18	
9.6	62.37	9.11	8.11	7.66	7.30	7.00	6.74	6.51	6.30	
9.7	63.02	9.28	8.26	7.81	7.44	7.13	6.87	6.63	6.42	
9.8	63.67	9.45	8.41	7.95	7.58	7.26	6.99	6.76	6.54	
9.9	64.32	9.63	8.57	8.10	7.72	7.40	7.12	6.88	6.67	
10.0	64.97	9.80	8.72	8.25	7.86	7.53	7.26	7.01	6.79	
10.1	65.62	9.98	8.88	8.40	8.00	7.67	7.39	7.14	6.91	
10.2	66.27	10.15	9.04	8.55	8.15	7.81	7.52	7.27	7.04	
10.3	66.92	10.33	9.20	8.70	8.29	7.95	7.66	7.40	7.16	
10.4	67.57	10.51	9.36	8.85	8.44	8.09	7.79	7.53	7.29	
10.5	68.22	10.69	9.52	9.01	8.59	8.23	7.93	7.66	7.42	
10.6	68.87	10.87	9.68	9.16	8.73	8.37	8.06	7.79	7.55	
10.7	69.52	11.06	9.85	9.32	8.88	8.52	8.20	7.93	7.68	
10.8	70.17	11.24	10.02	9.48	9.03	8.66	8.34	8.06	7.81	
10.9	70.82	11.43	10.18	9.63	9.19	8.81	8.48	8.20	7.94	
11.0	71.47	11.62	10.35	9.79	9.34	8.95	8.63	8.33	8.07	
11.1	72.12	11.81	10.52	9.96	9.49	9.10	8.77	8.47	8.21	
11.2	72.76	12.00	10.69	10.12	9.65	9.25	8.91	8.61	8.34	
11.3	73.41	12.19	10.86	10.28	9.80	9.40	9.06	8.75	8.48	
11.4	74.06	12.38	11.04	10.45	9.96	9.55	9.20	8.89	8.62	
11.5	74.71	12.58	11.21	10.61	10.12	9.71	9.35	9.04	8.76	
11.6	75.36	12.78	11.39	10.78	10.28	9.86	9.50	9.18	8.89	
11.7	76.01	12.97	11.57	10.95	10.44	10.01	9.65	9.32	9.04	
11.8	76.66	13.17	11.74	11.12	10.60	10.17	9.80	9.47	9.18	
11.9	77.31	13.37	11.92	11.29	10.77	10.33	9.95	9.62	9.32	
12.0	77.96	13.57	12.11	11.46	10.93	10.48	10.10	9.76	9.46	

Uponor PEX friction loss tables

2½" Uponor AquaPEX (100% water)

psi loss per 100 feet of tubing									
Velocity (ft/s)	gpm	40°F 4°C	60°F 16°C	80°F 27°C	100°F 38°C	120°F 49°C	140°F 60°C	160°F 71°C	180°F 82°C
1.5	14.85	0.27	0.23	0.22	0.20	0.19	0.19	0.18	0.17
1.6	15.84	0.30	0.26	0.24	0.23	0.22	0.21	0.20	0.19
1.7	16.83	0.33	0.29	0.27	0.26	0.24	0.23	0.22	0.22
1.8	17.82	0.37	0.32	0.30	0.28	0.27	0.26	0.25	0.24
1.9	18.81	0.40	0.35	0.33	0.31	0.30	0.28	0.27	0.26
2.0	19.80	0.44	0.38	0.36	0.34	0.32	0.31	0.30	0.29
2.1	20.79	0.48	0.42	0.39	0.37	0.35	0.34	0.33	0.32
2.2	21.78	0.52	0.45	0.43	0.40	0.38	0.37	0.35	0.34
2.3	22.77	0.56	0.49	0.46	0.44	0.42	0.40	0.38	0.37
2.4	23.76	0.61	0.53	0.50	0.47	0.45	0.43	0.41	0.40
2.5	24.75	0.65	0.57	0.54	0.51	0.48	0.46	0.45	0.43
2.6	25.74	0.70	0.61	0.57	0.54	0.52	0.50	0.48	0.46
2.7	26.73	0.74	0.65	0.61	0.58	0.55	0.53	0.51	0.49
2.8	27.72	0.79	0.70	0.65	0.62	0.59	0.57	0.55	0.53
2.9	28.71	0.84	0.74	0.70	0.66	0.63	0.60	0.58	0.56
3.0	29.70	0.90	0.79	0.74	0.70	0.67	0.64	0.62	0.60
3.1	30.69	0.95	0.83	0.78	0.74	0.71	0.68	0.66	0.63
3.2	31.68	1.00	0.88	0.83	0.79	0.75	0.72	0.69	0.67
3.3	32.67	1.06	0.93	0.88	0.83	0.79	0.76	0.73	0.71
3.4	33.66	1.12	0.98	0.92	0.88	0.84	0.80	0.77	0.75
3.5	34.65	1.18	1.03	0.97	0.92	0.88	0.85	0.82	0.79
3.6	35.64	1.23	1.09	1.02	0.97	0.93	0.89	0.86	0.83
3.7	36.63	1.30	1.14	1.08	1.02	0.98	0.94	0.90	0.87
3.8	37.62	1.36	1.20	1.13	1.07	1.02	0.98	0.95	0.91
3.9	38.61	1.42	1.25	1.18	1.12	1.07	1.03	0.99	0.96
4.0	39.60	1.49	1.31	1.24	1.17	1.12	1.08	1.04	1.00
4.1	40.59	1.55	1.37	1.29	1.23	1.17	1.13	1.09	1.05
4.2	41.58	1.62	1.43	1.35	1.28	1.22	1.18	1.13	1.10
4.3	42.57	1.69	1.49	1.41	1.34	1.28	1.23	1.18	1.14
4.4	43.57	1.76	1.55	1.47	1.39	1.33	1.28	1.23	1.19
4.5	44.56	1.83	1.62	1.53	1.45	1.39	1.33	1.28	1.24
4.6	45.55	1.90	1.68	1.59	1.51	1.44	1.39	1.34	1.29
4.7	46.54	1.98	1.75	1.65	1.57	1.50	1.44	1.39	1.34
4.8	47.53	2.05	1.82	1.71	1.63	1.56	1.50	1.44	1.39
4.9	48.52	2.13	1.88	1.78	1.69	1.61	1.55	1.50	1.45
5.0	49.51	2.21	1.95	1.84	1.75	1.67	1.61	1.55	1.50
5.1	50.50	2.29	2.02	1.91	1.81	1.74	1.67	1.61	1.56
5.2	51.49	2.37	2.09	1.98	1.88	1.80	1.73	1.67	1.61
5.3	52.48	2.45	2.17	2.04	1.94	1.86	1.79	1.72	1.67
5.4	53.47	2.53	2.24	2.11	2.01	1.92	1.85	1.78	1.73
5.5	54.46	2.61	2.32	2.18	2.08	1.99	1.91	1.84	1.78
5.6	55.45	2.70	2.39	2.26	2.15	2.05	1.97	1.91	1.84
5.7	56.44	2.79	2.47	2.33	2.22	2.12	2.04	1.97	1.90
5.8	57.43	2.87	2.55	2.40	2.29	2.19	2.10	2.03	1.96
5.9	58.42	2.96	2.62	2.48	2.36	2.26	2.17	2.09	2.03
6.0	59.41	3.05	2.71	2.55	2.43	2.33	2.24	2.16	2.09
6.1	60.40	3.14	2.79	2.63	2.50	2.40	2.30	2.22	2.15
6.2	61.39	3.23	2.87	2.71	2.58	2.47	2.37	2.29	2.22
6.3	62.38	3.33	2.95	2.79	2.65	2.54	2.44	2.36	2.28
6.4	63.37	3.42	3.04	2.87	2.73	2.61	2.51	2.43	2.35
6.5	64.36	3.52	3.12	2.95	2.81	2.69	2.58	2.49	2.41
6.6	65.35	3.61	3.21	3.03	2.88	2.76	2.66	2.56	2.48
6.7	66.34	3.71	3.30	3.11	2.96	2.84	2.73	2.64	2.55

2½" Uponor AquaPEX (100% water)

psi loss per 100 feet of tubing									
Velocity (ft/s)	gpm	40°F 4°C	60°F 16°C	80°F 27°C	100°F 38°C	120°F 49°C	140°F 60°C	160°F 71°C	180°F 82°C
6.8	67.33	3.81	3.38	3.20	3.04	2.91	2.80	2.71	2.62
6.9	68.32	3.91	3.47	3.28	3.12	2.99	2.88	2.78	2.69
7.0	69.31	4.01	3.56	3.37	3.21	3.07	2.96	2.85	2.76
7.1	70.30	4.12	3.66	3.45	3.29	3.15	3.03	2.93	2.83
7.2	71.29	4.22	3.75	3.54	3.37	3.23	3.11	3.00	2.91
7.3	72.28	4.33	3.84	3.63	3.46	3.31	3.19	3.08	2.98
7.4	73.27	4.43	3.94	3.72	3.54	3.40	3.27	3.16	3.06
7.5	74.26	4.54	4.03	3.81	3.63	3.48	3.35	3.23	3.13
7.6	75.25	4.65	4.13	3.90	3.72	3.56	3.43	3.31	3.21
7.7	76.24	4.76	4.23	4.00	3.81	3.65	3.51	3.39	3.28
7.8	77.23	4.87	4.33	4.09	3.90	3.73	3.60	3.47	3.36
7.9	78.22	4.98	4.43	4.19	3.99	3.82	3.68	3.55	3.44
8.0	79.21	5.09	4.53	4.28	4.08	3.91	3.76	3.63	3.52
8.1	80.20	5.21	4.63	4.38	4.17	4.00	3.85	3.72	3.60
8.2	81.19	5.32	4.73	4.48	4.27	4.09	3.94	3.80	3.68
8.3	82.18	5.44	4.84	4.58	4.36	4.18	4.02	3.89	3.76
8.4	83.17	5.55	4.94	4.68	4.46	4.27	4.11	3.97	3.85
8.5	84.16	5.67	5.05	4.78	4.55	4.36	4.20	4.06	3.93
8.6	85.15	5.79	5.16	4.88	4.65	4.46	4.29	4.14	4.01
8.7	86.14	5.91	5.27	4.98	4.75	4.55	4.38	4.23	4.10
8.8	87.13	6.04	5.37	5.08	4.85	4.65	4.47	4.32	4.19
8.9	88.12	6.16	5.49	5.19	4.95	4.74	4.57	4.41	4.27
9.0	89.11	6.28	5.60	5.29	5.05	4.84	4.66	4.50	4.36
9.1	90.10	6.41	5.71	5.40	5.15	4.94	4.75	4.59	4.45
9.2	91.09	6.53	5.82	5.51	5.25	5.03	4.85	4.68	4.54
9.3	92.08	6.66	5.94	5.62	5.36	5.13	4.95	4.78	4.63
9.4	93.07	6.79	6.05	5.73	5.46	5.23	5.04	4.87	4.72
9.5	94.06	6.92	6.17	5.84	5.57	5.34	5.14	4.97	4.81
9.6	95.05	7.05	6.28	5.95	5.67	5.44	5.24	5.06	4.90
9.7	96.04	7.18	6.40	6.06	5.78	5.54	5.34	5.16	5.00
9.8	97.03	7.32	6.52	6.17	5.89	5.65	5.44	5.25	5.09
9.9	98.02	7.45	6.64	6.29	6.00	5.75	5.54	5.35	5.19
10.0	99.01	7.58	6.76	6.40	6.11	5.86	5.64	5.45	5.28
10.1	100.00	7.72	6.89	6.52	6.22	5.96	5.74	5.55	5.38
10.2	100.99	7.86	7.01	6.64	6.33	6.07	5.85	5.65	5.48
10.3	101.98	8.00	7.13	6.75	6.44	6.18	5.95	5.75	5.57
10.4	102.97	8.14	7.26	6.87	6.56	6.29	6.06	5.85	5.67
10.5	103.96	8.28	7.38	6.99	6.67	6.40	6.16	5.96	5.77
10.6	104.95	8.42	7.51	7.11	6.79	6.51	6.27	6.06	5.87
10.7	105.94	8.56	7.64	7.23	6.90	6.62	6.38	6.17	5.97
10.8	106.93	8.70	7.77	7.36	7.02	6.73	6.49	6.27	6.08
10.9	107.92	8.85	7.90	7.48	7.14	6.85	6.60	6.38	6.18
11.0	108.91	8.99	8.03	7.60	7.26	6.96	6.71	6.48	6.28
11.1	109.90	9.14	8.16	7.73	7.38	7.08	6.82	6.59	6.39
11.2	110.89	9.29	8.29	7.86	7.50	7.19	6.93	6.70	6.49
11.3	111.88	9.44	8.43	7.98	7.62	7.31	7.04	6.81	6.60
11.4	112.87	9.59	8.56	8.11	7.74	7.43	7.16	6.92	6.71
11.5	113.86	9.74	8.70	8.24	7.86	7.55	7.27	7.03	6.81
11.6	114.85	9.89	8.84	8.37	7.99	7.66	7.39	7.14	6.92
11.7	115.84	10.05	8.97	8.50	8.11	7.79	7.50	7.25	7.03
11.8	116.83	10.20	9.11	8.63	8.24	7.91	7.62	7.37	7.14
11.9	117.82	10.35	9.25	8.77	8.37	8.03	7.74	7.48	7.25
12.0	118.81	10.51	9.39	8.90	8.49	8.15	7.86	7.60	7.36

Uponor PEX friction loss tables

3" Uponor AquaPEX (100% water)

psi loss per 100 feet of tubing										
Velocity (ft/s)	gpm	40°F 4°C	60°F 16°C	80°F 27°C	100°F 38°C	120°F 49°C	140°F 60°C	160°F 71°C	180°F 82°C	
1.5	21.12	0.21	0.19	0.17	0.16	0.16	0.15	0.14	0.14	
1.6	22.53	0.24	0.21	0.20	0.18	0.18	0.17	0.16	0.16	
1.7	23.93	0.27	0.23	0.22	0.21	0.20	0.19	0.18	0.17	
1.8	25.34	0.29	0.26	0.24	0.23	0.22	0.21	0.20	0.19	
1.9	26.75	0.32	0.28	0.26	0.25	0.24	0.23	0.22	0.21	
2.0	28.16	0.35	0.31	0.29	0.27	0.26	0.25	0.24	0.23	
2.1	29.57	0.38	0.34	0.32	0.30	0.29	0.27	0.26	0.25	
2.2	30.97	0.42	0.37	0.34	0.33	0.31	0.30	0.29	0.28	
2.3	32.38	0.45	0.40	0.37	0.35	0.34	0.32	0.31	0.30	
2.4	33.79	0.49	0.43	0.40	0.38	0.36	0.35	0.34	0.32	
2.5	35.20	0.52	0.46	0.43	0.41	0.39	0.37	0.36	0.35	
2.6	36.60	0.56	0.49	0.46	0.44	0.42	0.40	0.39	0.37	
2.7	38.01	0.60	0.53	0.49	0.47	0.45	0.43	0.41	0.40	
2.8	39.42	0.64	0.56	0.53	0.50	0.48	0.46	0.44	0.43	
2.9	40.83	0.68	0.60	0.56	0.53	0.51	0.49	0.47	0.45	
3.0	42.24	0.72	0.63	0.60	0.57	0.54	0.52	0.50	0.48	
3.1	43.64	0.76	0.67	0.63	0.60	0.57	0.55	0.53	0.51	
3.2	45.05	0.81	0.71	0.67	0.64	0.61	0.58	0.56	0.54	
3.3	46.46	0.85	0.75	0.71	0.67	0.64	0.62	0.59	0.57	
3.4	47.87	0.90	0.79	0.75	0.71	0.68	0.65	0.63	0.61	
3.5	49.28	0.95	0.83	0.79	0.75	0.71	0.69	0.66	0.64	
3.6	50.68	0.99	0.88	0.83	0.79	0.75	0.72	0.69	0.67	
3.7	52.09	1.04	0.92	0.87	0.82	0.79	0.76	0.73	0.71	
3.8	53.50	1.09	0.97	0.91	0.87	0.83	0.79	0.77	0.74	
3.9	54.91	1.15	1.01	0.95	0.91	0.87	0.83	0.80	0.78	
4.0	56.31	1.20	1.06	1.00	0.95	0.91	0.87	0.84	0.81	
4.1	57.72	1.25	1.11	1.04	0.99	0.95	0.91	0.88	0.85	
4.2	59.13	1.31	1.15	1.09	1.04	0.99	0.95	0.92	0.89	
4.3	60.54	1.36	1.20	1.14	1.08	1.03	0.99	0.96	0.93	
4.4	61.95	1.42	1.25	1.18	1.13	1.08	1.03	1.00	0.97	
4.5	63.35	1.48	1.31	1.23	1.17	1.12	1.08	1.04	1.01	
4.6	64.76	1.53	1.36	1.28	1.22	1.17	1.12	1.08	1.05	
4.7	66.17	1.59	1.41	1.33	1.27	1.21	1.17	1.12	1.09	
4.8	67.58	1.65	1.47	1.38	1.32	1.26	1.21	1.17	1.13	
4.9	68.99	1.72	1.52	1.44	1.37	1.31	1.26	1.21	1.17	
5.0	70.39	1.78	1.58	1.49	1.42	1.36	1.30	1.26	1.22	
5.1	71.80	1.84	1.63	1.54	1.47	1.40	1.35	1.30	1.26	
5.2	73.21	1.91	1.69	1.60	1.52	1.45	1.40	1.35	1.31	
5.3	74.62	1.97	1.75	1.65	1.57	1.51	1.45	1.40	1.35	
5.4	76.02	2.04	1.81	1.71	1.63	1.56	1.50	1.45	1.40	
5.5	77.43	2.11	1.87	1.77	1.68	1.61	1.55	1.49	1.45	
5.6	78.84	2.18	1.93	1.82	1.74	1.66	1.60	1.54	1.49	
5.7	80.25	2.25	1.99	1.88	1.79	1.72	1.65	1.59	1.54	
5.8	81.66	2.32	2.06	1.94	1.85	1.77	1.70	1.64	1.59	
5.9	83.06	2.39	2.12	2.00	1.91	1.83	1.76	1.70	1.64	
6.0	84.47	2.46	2.19	2.06	1.97	1.88	1.81	1.75	1.69	
6.1	85.88	2.53	2.25	2.13	2.03	1.94	1.87	1.80	1.74	
6.2	87.29	2.61	2.32	2.19	2.09	2.00	1.92	1.86	1.80	
6.3	88.70	2.68	2.39	2.25	2.15	2.06	1.98	1.91	1.85	
6.4	90.10	2.76	2.45	2.32	2.21	2.12	2.04	1.97	1.90	
6.5	91.51	2.84	2.52	2.38	2.27	2.18	2.09	2.02	1.96	
6.6	92.92	2.92	2.59	2.45	2.33	2.24	2.15	2.08	2.01	
6.7	94.33	2.99	2.66	2.52	2.40	2.30	2.21	2.14	2.07	

3" Uponor AquaPEX (100% water)

psi loss per 100 feet of tubing										
Velocity (ft/s)	gpm	40°F 4°C	60°F 16°C	80°F 27°C	100°F 38°C	120°F 49°C	140°F 60°C	160°F 71°C	180°F 82°C	
6.8	95.73	3.08	2.74	2.59	2.46	2.36	2.27	2.19	2.12	
6.9	97.14	3.16	2.81	2.65	2.53	2.42	2.33	2.25	2.18	
7.0	98.55	3.24	2.88	2.72	2.60	2.49	2.39	2.31	2.24	
7.1	99.96	3.32	2.96	2.80	2.66	2.55	2.46	2.37	2.30	
7.2	101.37	3.41	3.03	2.87	2.73	2.62	2.52	2.43	2.36	
7.3	102.77	3.49	3.11	2.94	2.80	2.68	2.58	2.50	2.42	
7.4	104.18	3.58	3.18	3.01	2.87	2.75	2.65	2.56	2.48	
7.5	105.59	3.66	3.26	3.09	2.94	2.82	2.71	2.62	2.54	
7.6	107.00	3.75	3.34	3.16	3.01	2.89	2.78	2.68	2.60	
7.7	108.41	3.84	3.42	3.23	3.08	2.96	2.85	2.75	2.66	
7.8	109.81	3.93	3.50	3.31	3.16	3.03	2.91	2.81	2.73	
7.9	111.22	4.02	3.58	3.39	3.23	3.10	2.98	2.88	2.79	
8.0	112.63	4.11	3.66	3.47	3.30	3.17	3.05	2.95	2.85	
8.1	114.04	4.20	3.75	3.54	3.38	3.24	3.12	3.01	2.92	
8.2	115.44	4.30	3.83	3.62	3.45	3.31	3.19	3.08	2.99	
8.3	116.85	4.39	3.91	3.70	3.53	3.39	3.26	3.15	3.05	
8.4	118.26	4.48	4.00	3.78	3.61	3.46	3.33	3.22	3.12	
8.5	119.67	4.58	4.08	3.87	3.69	3.54	3.41	3.29	3.19	
8.6	121.08	4.68	4.17	3.95	3.77	3.61	3.48	3.36	3.26	
8.7	122.48	4.77	4.26	4.03	3.85	3.69	3.55	3.43	3.33	
8.8	123.89	4.87	4.35	4.12	3.93	3.76	3.63	3.50	3.40	
8.9	125.30	4.97	4.44	4.20	4.01	3.84	3.70	3.58	3.47	
9.0	126.71	5.07	4.53	4.29	4.09	3.92	3.78	3.65	3.54	
9.1	128.12	5.17	4.62	4.37	4.17	4.00	3.85	3.72	3.61	
9.2	129.52	5.28	4.71	4.46	4.25	4.08	3.93	3.80	3.68	
9.3	130.93	5.38	4.80	4.55	4.34	4.16	4.01	3.88	3.76	
9.4	132.34	5.48	4.90	4.64	4.42	4.24	4.09	3.95	3.83	
9.5	133.75	5.59	4.99	4.73	4.51	4.33	4.17	4.03	3.90	
9.6	135.15	5.69	5.09	4.82	4.60	4.41	4.25	4.11	3.98	
9.7	136.56	5.80	5.18	4.91	4.68	4.49	4.33	4.18	4.05	
9.8	137.97	5.91	5.28	5.00	4.77	4.58	4.41	4.26	4.13	
9.9	139.38	6.02	5.38	5.09	4.86	4.66	4.49	4.34	4.21	
10.0	140.79	6.13	5.47	5.18	4.95	4.75	4.57	4.42	4.29	
10.1	142.19	6.24	5.57	5.28	5.04	4.83	4.66	4.50	4.36	
10.2	143.60	6.35	5.67	5.37	5.13	4.92	4.74	4.58	4.44	
10.3	145.01	6.46	5.77	5.47	5.22	5.01	4.83	4.67	4.52	
10.4	146.42	6.57	5.87	5.57	5.31	5.10	4.91	4.75	4.60	
10.5	147.83	6.69	5.98	5.66	5.40	5.19	5.00	4.83	4.68	
10.6	149.23	6.80	6.08	5.76	5.50	5.28	5.09	4.92	4.77	
10.7	150.64	6.92	6.18	5.86	5.59	5.37	5.17	5.00	4.85	
10.8	152.05	7.03	6.29	5.96	5.69	5.46	5.26	5.09	4.93	
10.9	153.46	7.15	6.39	6.06	5.78	5.55	5.35	5.17	5.02	
11.0	154.86	7.27	6.50	6.16	5.88	5.64	5.44	5.26	5.10	
11.1	156.27	7.39	6.61	6.26	5.98	5.74	5.53	5.35	5.18	
11.2	157.68	7.51	6.71	6.36	6.08	5.83	5.62	5.44	5.27	
11.3	159.09	7.63	6.82	6.47	6.17	5.93	5.71	5.53	5.36	
11.4	160.50	7.75	6.93	6.57	6.27	6.02	5.81	5.61	5.44	
11.5	161.90	7.87	7.04	6.68	6.37	6.12	5.90	5.70	5.53	
11.6	163.31	7.99	7.15	6.78	6.47	6.22	5.99	5.80	5.62	
11.7	164.72	8.12	7.26	6.89	6.58	6.31	6.09	5.89	5.71	
11.8	166.13	8.24	7.38	6.99	6.68	6.41	6.18	5.98	5.80	
11.9	167.54	8.37	7.49	7.10	6.78	6.51	6.28	6.07	5.89	
12.0	168.94	8.50	7.60	7.21	6.89	6.61	6.37	6.17	5.98	

Appendix C: Fitting equivalent length

Equivalent length of fittings

This section provides the equivalent length of piping pressure loss for several ProPEX fittings. The equivalent length is used to approximate the impact the fittings have on pressure loss across the piping length. The equivalent length for each fitting is shown in the tables below. Add the equivalent length to the total piping length for each fitting installed along the piping run. The total pressure loss is then computed from the adjusted total piping length. Equivalent

lengths are commonly utilized to calculate the Total Developed Length (TDL) along a critical piping path. All Uponor values represent pressure loss at 8 ft./sec.

Many methods exist for calculating the coefficient of velocity (C_v) across valves and fittings. The proceeding set of Uponor data was derived from empirical testing performed by NSF International and tested to ISA-S75.02 *Pressure Drop Measurement and C_v Calculations* at a measured and verified flow rate. In order to calculate equivalent length in feet, a quadratic equation is

utilized to determine pressure drop versus flow data at precisely 8 ft./sec.

Other common methods for calculating C_v include UL 1821 *Thermoplastic Sprinkler Pipe and Fittings for Fire Protection* and the use of flow modeling software. Through extensive testing and validation by NSF International, Uponor has built a complete and accurate data set for AquaPEX plumbing systems. When comparing equivalent length data across PEX fitting manufacturers, values may differ due to different testing methods and reported values at specific flow velocities other than 8 ft./sec.

For comparison purposes, NSF International tested commonly available ASTM F1807 *Brass Insert Fittings Utilizing Copper Crimp Ring for PEX Tubing Fittings* and ASTM F2159 *Plastic Insert Fittings Utilizing Copper Crimp Rings for PEX Tubing Fittings* to the ISA-S75.02 test method using the same quadratic equation as the Uponor ProPEX fittings to determine pressure drop versus flow data at precisely 8 ft./sec. Reference **Table C-1** for equivalent length comparisons.

Fittings	Nominal size (in.)	ASTM F1960	ASTM F1807	ASTM F2159	F1960 vs. F1807	F1960 vs. F2159
		Uponor ProPEX eq. length	Brass crimp ring eq. length	Plastic crimp ring eq. length		
Tee run	½	1	3.19	6.03	219.00%	503.00%
	¾	1.5	2.57	6.12	71.33%	308.00%
	1	1.3	2.49	6.26	91.54%	381.54%
Tee branch	½	6.3	9.05	15.34	43.65%	143.49%
	¾	15.6	10.16	17.04	-34.87%	9.23%
	1	12.7	11.87	20.17	-6.54%	58.82%
Elbow	½	10.4	9.11	13.53	-12.40%	30.10%
	¾	10.8	10.47	16.21	-3.06%	50.09%
	1	11.5	10.14	17.05	-11.83%	48.26%
Coupling	½	0.8	2.03	6.55	153.75%	718.75%
	¾	0.9	2.18	5.64	142.22%	526.67%
	1	0.9	1.49	4.97	65.56%	452.22%

Table C-1: Equivalent length comparison of various PEX fitting types



Fitting equivalent length and C_v data

EP tees	Flow/port	Avg. C_v	Eq. length (ft)
1/2 x 1/2 x 1/2	Through	7.7	1.0
	Branch	3.4	6.3
3/4 x 3/4 x 3/4	Through	15.7	1.5
	Branch	5.4	15.6
1 x 1 x 1	Through	30.5	1.3
	Branch	11.3	12.7
1 1/4 x 1 1/4 x 1 1/4	Through	34.0	3.8
	Branch	23.9	8.6
1 1/2 x 1 1/2 x 1 1/2	Through	63.7	1.8
	Branch	31.0	10.6
2 x 2 x 2	Through	150.7	0.8
	Branch	52.5	15.5
2 1/2 x 2 1/2 x 2 1/2	Through	197.2	2.7
	Branch	81.5	22.3
3 x 3 x 3	Through	286.6	2.8
	Branch	122.8	23.9

EP reducing tees	Flow/port	Avg. C_v	Eq. length (ft)
1/2 x 1/2 x 3/4	Through	3.8	4.1
	Branch	3.8	4.1
3/4 x 1/2 x 1/2	Through	4.6	3.5
	Branch	3.4	6.4
3/4 x 1/2 x 3/4	Through	5.4	2.3
	Branch	5.4	16.1
3/4 x 3/4 x 1/2	Through	14.2	2.0
	Branch	3.1	7.6
3/4 x 3/4 x 1	Through	8.7	5.7
	Branch	8.7	5.7
1 x 3/4 x 3/4	Through	12.8	2.4
	Branch	5.3	16.7
1 x 3/4 x 1	Through	12.9	2.4
	Branch	10.5	15.1
1 x 1 x 1/2	Through	32.2	1.2
	Branch	3.4	6.5
1 x 1 x 3/4	Through	27.8	1.7
	Branch	8.2	6.4
1 1/4 x 1 x 3/4	Through	21.0	3.4
	Branch	9.3	5.2
1 1/4 x 1 x 1	Through	11.7	11.0
	Branch	8.4	23.0

EP reducing tees	Flow/port	Avg. C_v	Eq. length (ft)
1 1/4 x 1 1/4 x 1/2	Through	45.2	1.9
	Branch	4.1	3.9
1 1/4 x 1 1/4 x 3/4	Through	43.4	2.3
	Branch	8.9	5.7
1 1/4 x 1 1/4 x 1	Through	33.0	4.2
	Branch	15.8	6.3
1 1/2 x 1 x 3/4	Through	19.5	4.0
	Branch	9.3	5.1
1 1/2 x 1 x 1	Through	18.9	4.3
	Branch	15.6	6.5
1 1/2 x 1 x 1 1/2	Through	19.1	4.2
	Branch	26.5	14.9
1 1/2 x 1 1/4 x 3/4	Through	33.1	4.2
	Branch	6.3	11.3
1 1/2 x 1 1/4 x 1	Through	36.4	3.1
	Branch	11.2	13.1
1 1/2 x 1 1/4 x 1 1/4	Through	45.4	2.0
	Branch	17.0	17.7
1 1/2 x 1 1/2 x 1/2	Through	60.5	2.4
	Branch	3.4	6.3
1 1/2 x 1 1/2 x 3/4	Through	56.0	2.9
	Branch	9.0	5.4
1 1/2 x 1 1/2 x 1	Through	53.8	3.1
	Branch	15.3	6.9
1 1/2 x 1 1/2 x 1 1/4	Through	54.3	3.2
	Branch	33.7	4.1
2 x 1 1/2 x 3/4	Through	43.5	4.9
	Branch	8.4	6.2
2 x 1 1/2 x 1	Through	42.4	5.5
	Branch	13.9	8.4
2 x 1 1/2 x 1 1/4	Through	41.8	5.6
	Branch	22.0	10.3
2 x 1 1/2 x 1 1/2	Through	42.1	5.4
	Branch	28.5	13.0
2 x 1 1/2 x 2	Through	38.6	6.6
	Branch	51.8	16.1
2 x 2 x 1/2	Through	111.1	2.7
	Branch	4.3	4.0
2 x 2 x 3/4	Through	115.0	2.7
	Branch	8.2	6.8

EP reducing tees
(continued)



EP reducing tees	Flow path	Avg. C_v	Eq. length (ft)
2 x 2 x 1	Through	119.7	2.4
	Branch	13.8	8.5
2 x 2 x 1¼	Through	107.0	3.1
	Branch	23.6	8.8
2 x 2 x 1½	Through	115.8	2.5
	Branch	29.9	11.7
2½ x 2 x 1½	Through	80.4	5.9
	Branch	30.2	11.2
2½ x 2 x 2	Through	79.5	5.7
	Branch	51.8	16.0
2½ x 2½ x ¾	Through	209.6	2.0
	Branch	8.5	6.0
2½ x 2½ x 1	Through	202.0	2.4
	Branch	17.5	5.0
2½ x 2½ x 1¼	Through	198.8	2.5
	Branch	22.4	9.7
2½ x 2½ x 1½	Through	200.0	2.5
	Branch	29.8	11.5
2½ x 2½ x 2	Through	193.2	2.7
	Branch	53.6	14.7
3 x 2 x 2	Through	69.9	8.1
	Branch	52.8	15.3
3 x 2½ x 1½	Through	132.5	7.5
	Branch	29.2	12.0
3 x 2½ x 2	Through	133.2	7.4
	Branch	51.7	16.4
3 x 3 x ¾	Through	294.9	2.7
	Branch	8.5	6.0
3 x 3 x 1	Through	291.4	2.8
	Branch	14.8	7.3
3 x 3 x 1¼	Through	290.4	3.0
	Branch	22.8	9.3
3 x 3 x 1½	Through	290.5	2.9
	Branch	29.9	11.3
3 x 3 x 2	Through	287.6	3.0
	Branch	53.8	14.6
3 x 3 x 2½	Through	288.3	3.0
	Branch	82.2	22.2

EP coupling



Nominal size (in)	Flow path	Avg. C_v	Eq. length (ft)
1/2 x 1/2	Through	8.3	0.8
3/4 x 1/2	Through	5.2	2.6
3/4 x 3/4	Through	19.0	0.9
1 x 3/4	Through	12.5	2.7
1 x 1	Through	33.8	0.9
1 1/4 x 3/4	Through	10.9	3.6
1 1/4 x 1	Through	22.3	2.6
1 1/4 x 1 1/4	Through	53.3	1.1
1 1/2 x 3/4	Through	10.8	3.5
1 1/2 x 1	Through	19.0	4.3
1 1/2 x 1 1/4	Through	33.9	3.7
1 1/2 x 1 1/2	Through	69.5	1.4
2 x 1 1/2	Through	45.2	4.6
2 x 2	Through	107.8	2.7
2 1/2 x 1 1/4	Through	29.3	5.4
2 1/2 x 1 1/2	Through	35.9	7.5
2 1/2 x 2	Through	82.6	5.4
2 1/2 x 2 1/2	Through	219.1	1.7
3 x 2	Through	73.4	7.2
3 x 2 1/2	Through	136.2	7.1
3 x 3	Through	320.6	1.9

45° elbow



Nominal size (in)	Flow path	Avg. C_v	Eq. length (ft)
1 1/2 x 1 1/2	Through	33.1	9.3
2 x 2	Through	68.9	8.8
2 1/2 x 2 1/2	Through	136.8	6.9
3 x 3	Through	195.5	8.3

90° elbow



Nominal size (in)	Flow path	Avg. C_v	Eq. length (ft)
1/2 x 1/2	Through	2.6	10.4
3/4 x 3/4	Through	6.7	10.8
1 x 1	Through	11.9	11.5
1 1/4 x 1 1/4	Through	22.2	10.0
1 1/2 x 1 1/2	Through	29.7	11.5
2 x 2	Through	50.2	17.1
2 1/2 x 2 1/2	Through	86.0	20.0
3 x 3	Through	125.0	23.2

Elbows



EP multiport elbows	Flow/port	Avg. C _v	Eq. length (ft)
EP flow-through multiport elbow, 3 outlets, ¾" x ¾" ProPEX	Through	7.1	8.8
	#2	3.4	6.3
EP flow-through multiport elbow, 4 outlets, ¾" x ¾" ProPEX	Through	7.1	8.9
	#3	3.4	6.4
1" EP branch multiport elbow, 10 outlets with mounting clips	#5	3.0	7.9

Flow-through



EP flow-through multiport tees	Flow/port	Avg. C _v	Eq. length (ft)
EP flow-through multiport tee, 2 outlets, ¾" x ¾" ProPEX	Through	15.3	1.6
	#2	3.4	6.4
EP flow-through multiport tee, 3 (1") outlets, 2" x 2" ProPEX	Through	99.0	3.9
	#2	13.4	9.0
EP flow-through multiport tee, 3 outlets, 1" x ¾" PEX	Through	11.6	3.2
	#2	3.7	5.4
EP flow-through multiport tee, 3 outlets, ¾" x ¾" ProPEX	Through	7.1	8.8
	#2	3.4	6.3
EP flow-through multiport tee, 3 (¾") outlets, 1¼" x 1¼" PEX	Through	45.9	7.9
	#2	1.8	7.1
EP flow-through multiport tee, 4 outlets, ¾" x ¾" ProPEX	Through	7.1	8.9
	#3	3.4	6.4
EP flow-through multiport tee, 4 outlets, 1" x 1" PEX	Through	29.3	1.5
	#3	3.2	7.5
EP flow-through multiport tee, 4 outlets, 1" x ¾" ProPEX	Through	11.7	3.0
	#3	4.0	4.5
EP flow-through multiport tee, 6 outlets, 1" x ¾" ProPEX	Through	11.8	3.1
	#3	3.5	5.8
EP flow-through multiport tee, 6 outlets, ¾" x ¾" ProPEX	Through	13.2	3.8
	#3	3.7	5.3
EP flow-through multiport tee, 6 outlets, 1" x 1" ProPEX	Through	25.1	2.5
	#3	3.1	7.6

Vertical



EP Flow-through multiport vertical tee	Flow/port	Avg. C _v	Eq. length (ft)
EP flow-through multiport vertical tee, 3 outlets, ¾" x ¾" x ¾" ProPEX	Tee to tee	13.6	2.3
	Tee to side	7.4	8.2
	Tee to #2	3.1	7.8
	Side to tee	6.9	9.5
	Side to #2	3.6	4.9

Branch



EP branch multiport tees	Flow/port	Avg. C _v	Eq. length (ft)
3/4" EP branch multiport tee, 3 outlets	#2	3.4	6.0
1 1/4" EP branch multiport tee, 3 (3/4") outlets	#2	7.9	7.1
1" EP branch multiport tee, 4 outlets	#3	4.2	3.9
3/4" EP branch multiport tee, 4 outlets	#3	3.3	6.7
1" EP branch multiport tee, 6 outlets	#3	3.6	5.4
3/4" EP branch multiport tee, 6 outlets	#3	4.1	3.8
3/4" EP branch multiport tee, 7 outlets with mounting clips	#4	2.6	10.6
1" EP branch multiport tee, 7 outlets with mounting clips	#4	2.6	10.7
3/4" EP branch multiport tee, 8 outlets with mounting clips	#4	2.6	10.9
1" EP branch multiport tee, 8 outlets with mounting clips	#4	3.2	6.1

Opposing



EP opposing-port multiport tees	Flow/port	Avg. C _v	Eq. length (ft)
3/4" EP branch opposing-port multiport tee, 3 outlets	#2	3.3	6.5
EP flow-through opposing-port multiport tee, 3 outlets, 3/4" x 3/4" ProPEX	Through	15.9	1.6
	#3	3.4	6.4
3/4" EP branch opposing-port multiport tee, 4 outlets	#3	3.5	6.0
EP flow-through opposing-port multiport tee, 4 outlets, 3/4" x 3/4" ProPEX	Through	16.9	1.3
	#3	3.4	6.3
EP flow-through opposing-port multiport tee, 6 outlets, 3/4" x 3/4" ProPEX	Through	16.4	1.3
	#3	3.4	6.2
3/4" EP branch opposing-port multiport tee, 8 outlets	#4	3.4	6.0

Sweat adapters



Nominal size (in)	Flow path	Avg. C _v	Eq. length (ft)
½ PEX x ½ copper	Through	5.7	2.0
½ PEX x ¾ copper	Through	5.1	2.7
¾ PEX x ½ copper	Through	8.8	1.4
¾ PEX x ¾ copper	Through	13.4	2.1
¾ PEX x 1 copper	Through	10.9	3.7
1 PEX x 1 copper	Through	22.1	2.4
1¼ PEX x 1¼ copper	Through	34.0	3.9
1½ PEX x 1½ copper	Through	45.5	4.3
2 PEX x 2 copper	Through	83.6	5.3
2½ PEX x 2½ copper	Through	136.2	6.9
3 PEX x 3 copper	Through	189.1	8.8

Fitting adapters



Nominal size (in)	Flow path	Avg. C _v	Eq. length (ft)
½ PEX x ½ copper	Through	7.7	1.0
½ PEX x ¾ copper	Cu to PEX	5.6	2.2
¾ PEX x ½ copper	PEX to Cu	8.8	1.5
¾ PEX x ¾ copper	Through	15.7	1.5
¾ PEX x 1 copper	Cu to PEX	11.4	3.1
1 PEX x 1 copper	Through	30.5	1.3
1¼ PEX x 1¼ copper	Through	34.0	3.8
1½ PEX x 1½ copper	Through	63.7	1.8
2 PEX x 2 copper	Through	150.7	0.8

Male adapters



Nominal size (in)	Flow path	Avg. C _v	Eq. length (ft)
½ PEX x ½ MNPT	Through	5.0	2.3
½ PEX x ¾ MNPT	NPT to PEX	6.2	1.8
¾ PEX x ¾ MNPT	Through	11.3	2.7
¾ PEX x 1 MNPT	NPT to PEX	10.9	3.4
1 PEX x ¾ MNPT	PEX to NPT	17.8	1.2
1 PEX x 1 MNPT	Through	19.9	3.2
1¼ PEX x 1¼ MNPT	Through	32.4	4.2
1½ PEX x 1½ MNPT	Through	39.3	5.5
2 PEX x 2 MNPT	Through	78.6	5.6
2½ PEX x 2½ MNPT	Through	227.3	1.5
3 PEX x 3 MNPT	Through	187.5	9.1

Female adapters



Nominal size (in)	Flow path	Avg. C_v	Eq. length (ft)
½ PEX x ½ FNPT	Through	4.8	2.5
½ PEX x ¾ FNPT	NPT to PEX	5.1	2.7
¾ PEX x ¾ FNPT	Through	12.0	2.3
¾ PEX x 1 FNPT	NPT to PEX	10.8	3.6
1 PEX x 1 FNPT	Through	19.7	3.8
1¼ PEX x 1¼ FNPT	Through	30.8	4.8
1½ PEX x 1½ FNPT	Through	40.9	5.1
2 PEX x 2 FNPT	Through	77.7	5.7

CPVC adapters



Nominal size (in)	Flow path	Avg. C_v	Eq. length (ft)
1¼ PEX x 1¼ CPVC spigot	CVPC to PEX	42.6	2.1
1¼ PEX x 1¼ CPVC socket	CVPC to PEX	43.3	2.0
1½ PEX x 1½ CPVC spigot	CVPC to PEX	55.7	2.6
1½ PEX x 1½ CPVC socket	CVPC to PEX	54.1	2.8
2 PEX x 2 CPVC spigot	CVPC to PEX	110.2	2.5
2 PEX x 2 CPVC socket	CVPC to PEX	112.6	2.4

Groove adapters



Nominal size (in)	Avg. C_v^1	Eq. Length (ft) ¹	Avg. C_v^2	Eq. Length (ft) ²
2 PEX x 2 CTS groove	86.1	4.9	141.4	1.0
2 PEX x 2 IPS groove	79.7	5.9	114.5	2.3
2 PEX x 2½ CTS groove	73.2	7.3	128.3	1.6
2 PEX x 2½ IPS groove	71.6	7.6	124.0	1.7
2½ PEX x 2 IPS groove	195.6	2.3	239.5	1.2
2½ PEX x 2½ CTS groove	138.7	6.5	222.7	1.5
2½ PEX x 2½ IPS groove	130.2	7.6	202.0	2.4
2½ PEX x 3 IPS groove	114.9	10.2	199.8	2.4
3 PEX x 2½ IPS groove	250.7	4.2	334.4	1.4
3 PEX x 3 CTS groove	192.3	8.3	338.3	1.6
3 PEX x 3 IPS groove	177.4	10.0	282.4	2.8

¹Copper-to-PEX flow
²PEX-to-copper flow

Flange adapters



Nominal size (in)	Flow path	Avg. C _v	Eq. length (ft)
2½ PEX x flange	Through	131.5	7.6
3 PEX x flange	Through	310.7	2.2

ProPEX LF brass commercial ball valve (full port)



Nominal size (in)	Avg. C _v	Equivalent length (ft)
½ PEX x ½ PEX	7.0	2.8
¾ PEX x ¾ PEX	18.7	3.3
1 PEX x 1 PEX	29.0	4.3
1¼ PEX x 1¼ PEX	54.7	4.8
1½ PEX x 1½ PEX	68.2	5.7
2 PEX x 2 PEX	132.2	7.1

Appendix D: ProPEX fitting dimensions

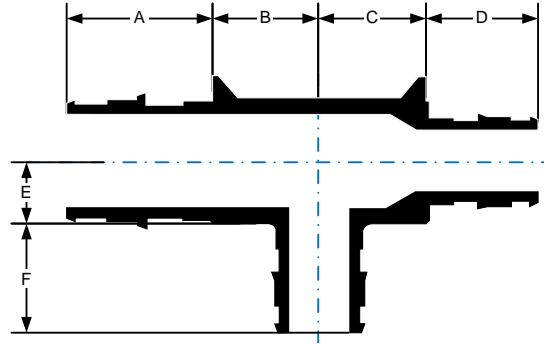

ProPEX EP reducing tees		A	B	C	D	E	F
Description	Part no.	in/mm	in/mm	in/mm	in/mm	in/mm	in/mm
½" PEX x ½" PEX x ¾" PEX	Q4755575	¾	1 ¹ / ₁₆	1 ¹ / ₁₆	¾	½	1 ⁵ / ₁₆
		18	18	18	18	13	24
¾" PEX x ½" PEX x ½" PEX	Q4757555	1 ⁵ / ₁₆	1 ¹ / ₁₆	1 ¹ / ₁₆	¾	½	¾
		24	18	18	18	13	18
¾" PEX x ½" PEX x ¾" PEX	Q4757557	1 ⁵ / ₁₆	1 ¹ / ₁₆	1 ¹ / ₁₆	¾	½	1 ⁵ / ₁₆
		24	18	18	18	13	24
¾" PEX x ¾" PEX x 5/8" PEX	Q4757563	1 ⁵ / ₁₆	1 ¹ / ₁₆	1 ¹ / ₁₆	1 ⁵ / ₁₆	9/16	7/8
		24	18	18	24	14	22
¾" PEX x ¾" PEX x ½" PEX	Q4757550	1 ⁵ / ₁₆	1 ¹ / ₁₆	1 ¹ / ₁₆	1 ⁵ / ₁₆	9/16	¾
		24	18	18	24	14	18
¾" PEX x ¾" PEX x 1" PEX	Q4757710	1 ⁵ / ₁₆	7/8	7/8	1 ⁵ / ₁₆	1 ¹ / ₁₆	1 ³ / ₁₆
		24	22	22	24	18	30
1" PEX x ¾" PEX x ¾" PEX	Q4751775	1 ³ / ₁₆	7/8	7/8	1 ⁵ / ₁₆	1 ¹ / ₁₆	1 ⁵ / ₁₆
		30	22	22	24	18	24
1" PEX x ¾" PEX x 1" PEX	Q4751751	1 ³ / ₁₆	7/8	7/8	1 ⁵ / ₁₆	1 ¹ / ₁₆	1 ³ / ₁₆
		30	22	22	24	18	30
1" PEX x 1" PEX x ½" PEX	Q4751150	1 ³ / ₁₆	7/8	7/8	1 ³ / ₁₆	1 ¹ / ₁₆	¾
		30	22	22	30	18	18
1" PEX x 1" PEX x ¾" PEX	Q4751175	1 ³ / ₁₆	7/8	7/8	1 ³ / ₁₆	1 ¹ / ₁₆	1 ⁵ / ₁₆
		30	22	22	30	18	24
1¼" PEX x 1" PEX x ¾" PEX	Q4751317	1 ³ / ₁₆	1 ⁵ / ₁₆	1 ⁵ / ₁₆	1 ⁷ / ₁₆	1 ⁵ / ₁₆	1 ⁵ / ₁₆
		30	25	25	37	24	24
1¼" PEX x 1" PEX x 1" PEX	Q4751311	1 ⁷ / ₁₆	1 ⁵ / ₁₆	1 ⁵ / ₁₆	1 ³ / ₁₆	1 ⁵ / ₁₆	1 ³ / ₁₆
		37	25	25	30	24	30
1¼" PEX x 1¼" PEX x ½" PEX	Q4751350	1 ⁷ / ₁₆	¾	¾	1 ⁷ / ₁₆	¾	¾
		37	19	19	37	19	18
1¼" PEX x 1¼" PEX x ¾" PEX	Q4751337	1 ⁷ / ₁₆	7/8	7/8	1 ⁷ / ₁₆	¾"	1 ⁵ / ₁₆
		37	23	23	37	19	24
1¼" PEX x 1¼" PEX x 1" PEX	Q4751331	1 ⁷ / ₁₆	1 ⁵ / ₁₆	1 ⁵ / ₁₆	1 ⁷ / ₁₆	1 ⁵ / ₁₆	1 ³ / ₁₆
		37	25	25	37	24	30
1½" PEX x 1" PEX x ¾" PEX	Q4751517	1 ¹¹ / ₁₆	1 ³ / ₁₆	1 ³ / ₁₆	1 ³ / ₁₆	1 ¹ / ₈	1 ⁵ / ₁₆
		43	30	30	30	28	24
1½" PEX x 1" PEX x 1" PEX	Q4751511	1 ¹¹ / ₁₆	1 ³ / ₁₆	1 ³ / ₁₆	1 ³ / ₁₆	1 ¹ / ₈	1 ³ / ₁₆
		43	30	30	30	28	30
1½" PEX x 1" PEX x 1½" PEX	Q4751505	1 ¹¹ / ₁₆	1¼	1¼	1 ³ / ₁₆	1 ⁵ / ₁₆	1 ¹¹ / ₁₆
		43	32	32	30	24	43

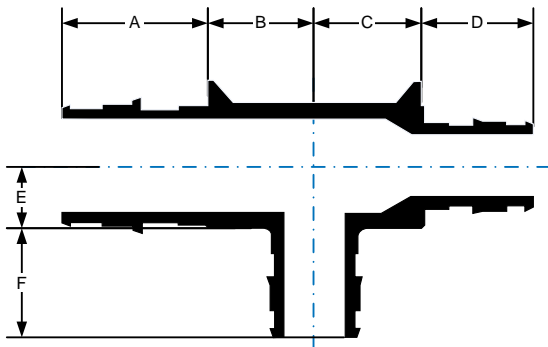

ProPEX EP reducing tees		A	B	C	D	E	F
Description	Part no.	in/mm	in/mm	in/mm	in/mm	in/mm	in/mm
1½" PEX x 1¼" PEX x ¾" PEX	Q4751537	1 ¹¹ / ₁₆	1 ¹ / ₈	1 ¹ / ₈	1 ¹ / ₁₆	7 ⁷ / ₈	1 ⁹ / ₁₆
		43	29	29	37	23	24
1½" PEX x 1¼" PEX x 1" PEX	Q4751531	1 ¹¹ / ₁₆	1 ¹ / ₈	1 ¹ / ₈	1 ¹ / ₁₆	7 ⁷ / ₈	1 ³ / ₁₆
		43	29	29	37	23	30
1½" PEX x 1¼" PEX x 1¼" PEX	Q4751533	1 ¹¹ / ₁₆	1 ¹ / ₈	1 ¹ / ₈	1 ¹ / ₁₆	7 ⁷ / ₈	1 ⁷ / ₁₆
		43	29	29	37	23	37
1½" PEX x 1½" PEX x ½" PEX	Q4751550	1 ¹¹ / ₁₆	¾	¾	1 ¹¹ / ₁₆	1 ³ / ₁₆	¾
		43	19	19	43	21	18
1½" PEX x 1½" PEX x ¾" PEX	Q4751557	1 ¹¹ / ₁₆	1 ³ / ₁₆	1 ³ / ₁₆	1 ¹¹ / ₁₆	1 ¹ / ₈	1 ⁵ / ₁₆
		43	30	30	43	28	24
1½" PEX x 1½" PEX x 1" PEX	Q4751551	1 ¹¹ / ₁₆	1 ³ / ₁₆	1 ³ / ₁₆	1 ¹¹ / ₁₆	1 ¹ / ₈	1 ³ / ₁₆
		43	30	30	43	28	30
1½" PEX x 1½" PEX x 1¼" PEX	Q4751553	1 ¹¹ / ₁₆	1 ³ / ₁₆	1 ³ / ₁₆	1 ¹¹ / ₁₆	1 ¹ / ₈	1 ⁷ / ₁₆
		43	30	30	43	28	37
2" PEX x 1½" PEX x ¾" PEX	Q4752575	2 ³ / ₁₆	1 ¹ / ₈	1 ¹ / ₈	1 ¹¹ / ₁₆	1 ¹ / ₈	1 ⁹ / ₁₆
		55	34	34	43	33	24
2" PEX x 1½" PEX x 1" PEX	Q4752051	2 ³ / ₁₆	1 ¹ / ₈	1 ⁵ / ₁₆	1 ¹¹ / ₁₆	1 ¹ / ₈	1 ³ / ₁₆
		55	34	34	43	33	30
2" PEX x 1½" PEX x 1¼" PEX	Q4752053	2 ³ / ₁₆	1 ³ / ₈	1 ³ / ₈	1 ¹¹ / ₁₆	1 ⁵ / ₁₆	1 ⁷ / ₁₆
		55	35	35	43	33	37
2" PEX x 1½" PEX x 1½" PEX	Q4752055	2 ³ / ₁₆	1 ³ / ₈	1 ³ / ₈	1 ¹¹ / ₁₆	1 ¹ / ₈	1 ¹¹ / ₁₆
		55	35	35	43	33	43
2" PEX x 1½" PEX x 2" PEX	Q4752152	2 ³ / ₁₆	1 ³ / ₄	1 ³ / ₄	1 ¹¹ / ₁₆	1 ¹ / ₈	2 ³ / ₁₆
		55	44	44	43	26	55
2" PEX x 2" PEX x ½" PEX	Q4752250	2 ³ / ₁₆	¾	¾	2 ³ / ₁₆	1 ¹ / ₈	¾
		55	19	19	55	26	18
2" PEX x 2" PEX x ¾" PEX	Q4752275	2 ³ / ₁₆	1 ⁵ / ₁₆	1 ⁵ / ₁₆	2 ³ / ₁₆	1 ⁵ / ₁₆	1 ⁵ / ₁₆
		55	34	34	55	33	24
2" PEX x 2" PEX x 1" PEX	Q4752210	2 ³ / ₁₆	1 ¹ / ₈	1 ¹ / ₈	2 ³ / ₁₆	1 ¹ / ₈	1 ³ / ₁₆
		55	34	34	55	33	30
2" PEX x 2" PEX x 1¼" PEX	Q4752213	2 ³ / ₁₆	1 ¹ / ₈	1 ⁵ / ₁₆	2 ³ / ₁₆	1 ¹ / ₈	1 ⁷ / ₁₆
		55	34	34	55	33	37
2" PEX x 2" PEX x 1½" PEX	Q4752215	2 ³ / ₁₆	1 ¹ / ₈	1 ⁵ / ₁₆	2 ³ / ₁₆	1 ¹ / ₈	1 ¹¹ / ₁₆
		55	34	34	55	33	43

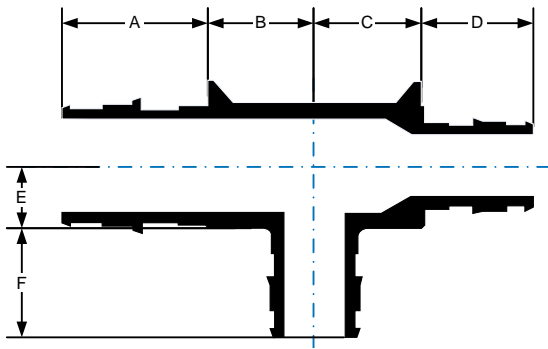

ProPEX EP reducing tees		A	B	C	D	E	F
Description	Part no.	in/mm	in/mm	in/mm	in/mm	in/mm	in/mm
2½" PEX x 2" PEX x 1½" PEX	Q4752525	2 ¹³ / ₁₆	1 ⁵ / ₈	1 ⁵ / ₈	2 ³ / ₁₆	1 ⁵ / ₁₆	1 ¹ / ₁₆
		72	41	41	55	33	43
2½" PEX x 2" PEX x 2" PEX	Q4752522	2 ¹³ / ₁₆	2	2	2 ³ / ₁₆	1 ⁵ / ₁₆	2 ³ / ₁₆
		72	51	51	55	33	55
2½" PEX x 2½" PEX x ¾" PEX	Q4752557	2 ¹³ / ₁₆	1 ⁵ / ₈	1 ⁵ / ₈	2 ¹³ / ₁₆	1 ⁵ / ₁₆	1 ⁵ / ₁₆
		72	29	29	72	33	24
2½" PEX x 2½" PEX x 1" PEX	Q4752510	2 ¹³ / ₁₆	1¼	1¼	2 ¹³ / ₁₆	1 ⁵ / ₁₆	1 ³ / ₁₆
		72	32	32	72	33	30
2½" PEX x 2½" PEX x 1¼" PEX	Q4752513	2 ¹³ / ₁₆	1½	1½	2 ¹³ / ₁₆	1 ⁵ / ₁₆	1 ⁷ / ₁₆
		72	38	38	72	33	37
2½" PEX x 2½" PEX x 1½" PEX	Q4752515	2 ¹³ / ₁₆	1 ⁵ / ₈	1 ⁵ / ₈	2 ¹³ / ₁₆	1 ⁵ / ₁₆	1 ¹ / ₁₆
		72	41	41	72	33	43
2½" PEX x 2½" PEX x 2" PEX	Q4752520	2 ¹³ / ₁₆	2	2	2 ¹³ / ₁₆	1¼	2 ³ / ₁₆
		72	51	51	72	32	55
3" PEX x 2" PEX x 2" PEX	Q4753220	3 ³ / ₈	2	2	2 ³ / ₁₆	1 ⁵ / ₁₆	2 ³ / ₁₆
		86	51	51	55	39	55
3" PEX x 2½" PEX x 1½" PEX	Q4753215	3 ³ / ₈	1 ⁵ / ₈	1 ⁵ / ₈	2 ¹³ / ₁₆	1 ⁵ / ₁₆	1 ¹ / ₁₆
		86	41	41	72	39	43
3" PEX x 2½" PEX x 2" PEX	Q4753252	3 ³ / ₈	2	2	2 ¹³ / ₁₆	1 ⁵ / ₁₆	2 ³ / ₁₆
		86	51	51	72	39	55
3" PEX x 3" PEX x ¾" PEX	Q4753375	3 ³ / ₈	1 ⁵ / ₈	1 ⁵ / ₈	3 ³ / ₈	1 ⁵ / ₁₆	1 ⁵ / ₁₆
		86	29	29	86	39	24
3" PEX x 3" PEX x 1" PEX	Q4753310	3 ³ / ₈	1¼	1¼	3 ³ / ₈	1 ⁵ / ₁₆	1 ³ / ₁₆
		86	32	32	86	39	30
3" PEX x 3" PEX x 1¼" PEX	Q4753313	3 ³ / ₈	1½	1½	3 ³ / ₈	1 ⁵ / ₁₆	1 ⁷ / ₁₆
		86	38	38	86	39	37
3" PEX x 3" PEX x 1½" PEX	Q4753315	3 ³ / ₈	1 ⁵ / ₈	1 ⁵ / ₈	3 ³ / ₈	1 ⁵ / ₁₆	1 ¹ / ₁₆
		86	41	41	86	39	43
3" PEX x 3" PEX x 2" PEX	Q4753320	3 ³ / ₈	2	2	3 ³ / ₈	1 ⁵ / ₁₆	2 ¹³ / ₁₆
		86	51	51	86	39	72
3" PEX x 3" PEX x 2½" PEX	Q4753325	3 ³ / ₈	2½	2½	3 ³ / ₈	1 ⁵ / ₁₆	2 ¹³ / ₁₆
		86	64	64	86	39	72

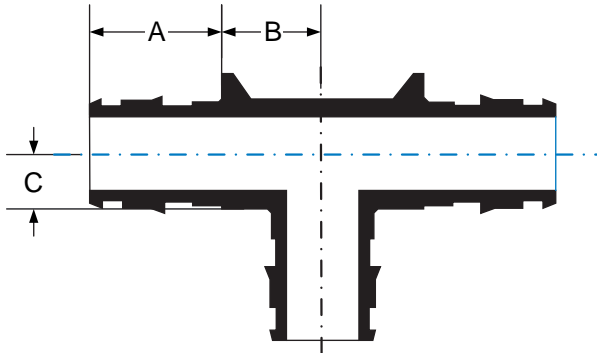

ProPEX tees		A	B	C
Description	Part no.	in/mm	in/mm	in/mm
½" PEX x ½" PEX x ½" PEX	Q4755050	¾	⅞	⅜
		18	15	10
½" PEX x ½" PEX x ½" PEX	LF4705050	1⅛	⅞	⅝
		18	14	8
¾" PEX x ¾" PEX x ¾" PEX	Q4757575	1⅝	1⅛	½
		24	18	13
¾" PEX x ¾" PEX x ¾" PEX	LF4707575	1⅝	1⅛	⅜
		24	18	10
1" PEX x 1" PEX x 1" PEX	Q4751010	1⅜	⅞	1⅛
		30	22	18
1" PEX x 1" PEX x 1" PEX	LF4701010	1⅜	⅞	⅞
		30	22	14
1¼" PEX x 1¼" PEX x 1¼" PEX	Q4751313	1⅞	1⅝	1⅝
		37	25	24
1½" PEX x 1½" PEX x 1½" PEX	Q4751515	1⅞	1⅜	1⅞
		43	30	28
2" PEX x 2" PEX x 2" PEX	Q4752000	2⅜	1⅞	1⅞
		55	40	41
2½" PEX x 2½" PEX x 2½" PEX	Q4752500	2⅞	2⅞	1⅞
		72	62	34
3" PEX x 3" PEX x 3" PEX	Q4753000	3⅜	2¾	1⅞
		86	70	37

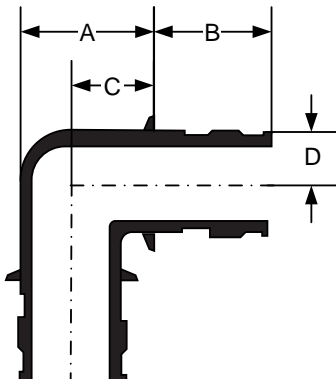

EP elbow

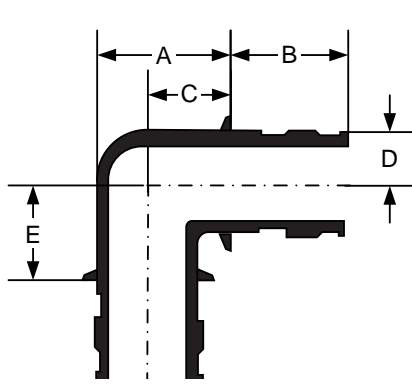

Brass elbow

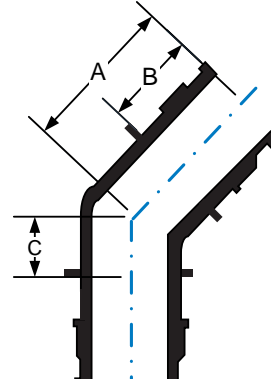

EP elbow

ProPEX elbows		A	B	C	D	E
Description	Part no.	in/mm	in/mm	in/mm	in/mm	in/mm
½" PEX x ½" PEX EP elbow	Q4760500	1¼ ₁₆	¾	9 ₁₆	¼	
		21	18	14	7	
¾" PEX x ¾" PEX EP elbow	Q4760750	1¼ ₁₆	19 ₁₆	1¼ ₁₆	3 ₈	
		27	24	17	10	
¾" PEX x ¾" PEX brass elbow	LF4710750	1¼ ₁₆	19 ₁₆	1¼ ₁₆	3 ₈	3 ₈
		27	24	18	10	10
1" PEX x 1" PEX EP elbow	Q4761000	1 ⁵ / ₈	1 ¹ / ₁₆	7 ₈	19 ₁₆	
		42	30	22	20	
1" PEX x 1" PEX brass elbow	LF4711000	1¼	1 ¹ / ₁₆	7 ₈	19 ₁₆	9 ₁₆
		36	30	22	14	14
1¼" PEX x 1¼" PEX EP elbow	Q4761250	1¾	1 ⁷ / ₁₆	1 ¹ / ₈	5 ₈	
		43	37	28	15	
1½" PEX x 1½" PEX EP elbow	Q4761500	1 ⁷ / ₈	1 ¹ / ₁₆	1 ¹ / ₁₆	1 ¹ / ₁₆	
		47	43	30	17	
1½" PEX x 1½" PEX 45 elbow	Q4761515	2 ⁵ / ₁₆	1 ¹ / ₁₆	5 ₈		
		59	43	15		
2" PEX x 2" PEX EP elbow	Q4762000	2 ⁹ / ₁₆	2 ³ / ₁₆	1 ⁵ / ₈	1 ⁵ / ₁₆	
		65	55	41	24	
2" PEX x 2" PEX 45 elbow	Q4762020	2 ¹⁵ / ₁₆	2 ³ / ₁₆	¾		
		74	55	19		
2½" PEX x 2½" PEX EP elbow	Q4762500	3 ⁵ / ₁₆	2 ¹ / ₁₆	2 ¹ / ₈	1 ³ / ₁₆	
		84	72	53	31	
2½" PEX x 2½" PEX 45 elbow	Q4762525	3 ¹³ / ₁₆	2 ¹ / ₁₆	1		
		97	72	25		
3" PEX x 3" PEX EP elbow	Q4763000	3 ¹⁵ / ₁₆	3 ³ / ₈	2½	1 ⁷ / ₁₆	
		99	86	64	36	
3" PEX x 3" PEX 45 elbow	Q4763030	4½	3 ³ / ₈	1 ¹ / ₈		
		114	86	28		

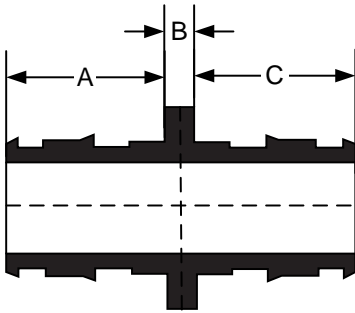

ProPEX couplings		A	B	C
Description	Part no.	in/mm	in/mm	in/mm
½" PEX x ½" PEX	Q4775050	¾	⅛	¾
		18	3	18
	LF4545050	1⅞	⅛	1⅞
		18	3	18
¾" PEX x ¾" PEX	Q4777575	1⅝	⅛	1⅝
		24	3	24
	LF4547575	1⅝	⅛	1⅝
		24	3	24
1" PEX x 1" PEX	Q4771010	1⅜	⅛	1⅜
		30	3	30
	LF4541010	1⅜	⅛	1⅜
		30	3	30
1¼" PEX x 1¼" PEX	Q4771313	1⅞	⅛	1⅞
		37	3	37
1½" PEX x 1½" PEX	Q4771515	1⅞	⅛	1⅞
		44	3	44
2" PEX x 2" PEX	Q4772020	2⅞	¼	2⅞
		55	6	55
2½" PEX x 2½" PEX	Q4772525	2⅞	¼	2⅞
		72	6	72
3" PEX x 3" PEX	Q4773030	3⅝	¼	3⅝
		86	6	86

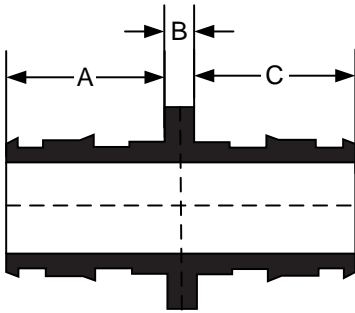

ProPEX reducing couplings		A	B	C
Description	Part no.	in/mm	in/mm	in/mm
¾" PEX x ½" PEX	Q4775075	15/16	1/8	¾
		24	3	19
1" PEX x ¾" PEX	Q4777510	13/16	1/8	15/16
		30	3	24
	LF4547510	13/16	1/8	15/16
1¼" PEX x ¾" PEX	Q4771307	17/16	1/8	15/16
		37	3	24
1¼" PEX x 1" PEX	Q4771310	17/16	1/8	13/16
		37	3	30
1½" PEX x ¾" PEX	Q4771507	11/16	1/8	15/16
		44	3	24
1½" PEX x 1" PEX	Q4771510	11/16	1/8	13/16
		44	3	30
1½" PEX x 1¼" PEX	Q4771513	11/16	1/8	17/16
		44	3	37
2" PEX x 1½" PEX	Q4772015	23/16	¼	11/16
		55	6	44
2½" PEX x 1¼" PEX	Q4772513	21/16	¼	17/16
		72	6	37
2½" PEX x 1½" PEX	Q4772515	21/16	¼	11/16
		72	6	44
2½" PEX x 2" PEX	Q4772520	21/16	¼	23/16
		72	6	55
3" PEX x 2" PEX	Q4773020	33/16	¼	23/16
		86	6	55
3" PEX x 2½" PEX	Q4773025	33/16	¼	21/16
		86	6	72

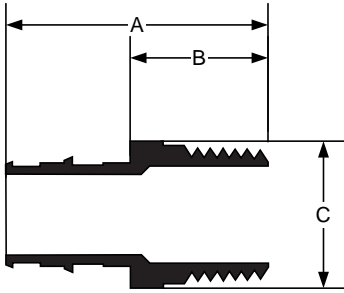

ProPEX brass male threaded adapters		A	B	C
Description	Part no.	in/mm	in/mm	in/mm
3/8" PEX x 1/2" NPT	LF4523850	1 5/8	1	7/8
		41	25	22
1/2" PEX x 1/2" NPT	Q5525050	1 5/8	7/8	7/8
		41	23	22
	LF4525050	1 11/16	1 5/8	7/8
1/2" PEX x 3/4" NPT	LF4525075	42	24	22
		1 15/16	1 1/16	1 1/8
3/4" PEX x 3/4" NPT	LF4527575	45	27	29
		1 1/8	1	1 1/8
	Q5527575	48	25	29
3/4" PEX x 1" NPT	LF4527510	1 1/8	7/8	1 1/8
		47	23	29
	Q5527510	2 1/4	1 1/4	1 3/8
1" PEX x 3/4" NPT	LF4521075	56	32	35
		2	1 1/16	1 3/8
	Q5521075	51	27	35
1" PEX x 1" NPT	LF4521010	2 1/4	1 1/16	1 1/4
		57	27	32
	Q5521010	2 1/16	1 1/16	1 1/4
1 1/4" PEX x 1 1/4" NPT	LF4521313	53	27	29
		2 5/8	1 3/8	1 3/8
	Q5521313	66	30	44
1 1/2" PEX x 1 1/2" NPT	LF4521515	2 1/2	1 1/16	1 1/4
		64	27	44
	Q5521515	3	1 1/4	2
2" PEX x 2" NPT	LF4522020	76	32	51
		2 15/16	1 1/4	2
	Q5522020	74	32	51
2 1/2" PEX x 2 1/2" NPT	LF4522525	3 3/16	1 3/8	2 3/8
		90	36	60
	Q5522525	3 7/16	1 1/16	2 3/8
3" PEX x 3" NPT	LF4523030	87	33	60
		4 15/16	2	3 1/4
		123	51	83
		5 1/2	2 1/8	3 3/4
		140	55	95

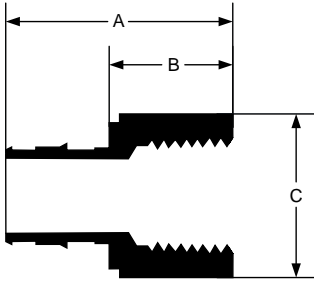

ProPEX brass female threaded adapters		A	B	C
Description	Part no.	in/mm	in/mm	in/mm
½" PEX x ½" NPT	Q5575050	1 ¹ / ₁₆	7 ⁷ / ₈	1
		40	22	25
	LF4575050	1 ¹ / ₁₆	7 ⁷ / ₈	1
		40	22	25
½" PEX x ¾" NPT	LF4575075	1 ³ / ₄	1 ¹ / ₁₆	1 ¹ / ₁₆
		44	26	30
¾" PEX x ¾" NPT	Q5577575	1 ⁷ / ₈	7 ⁷ / ₈	1 ¹ / ₁₆
		47	23	30
	LF4577575	1 ⁷ / ₈	7 ⁷ / ₈	1 ¹ / ₁₆
		47	23	30
¾" PEX x 1" NPT	Q5577510	2 ¹ / ₈	1 ³ / ₁₆	1 ¹ / ₂
		54	32	38
	LF4577510	2 ⁹ / ₁₆	1 ¹ / ₄	1 ¹ / ₂
		56	32	38
1" PEX x 1" NPT	Q5571010	2 ³ / ₈	1 ¹ / ₁₆	1 ¹ / ₂
		60	30	38
	LF4571010	2 ³ / ₈	1 ¹ / ₁₆	1 ¹ / ₂
		60	30	38
1¼" PEX x 1¼" NPT	Q5571313	2 ⁹ / ₁₆	1 ¹ / ₈	2
		65	28	51
	LF4571313	2 ⁹ / ₁₆	1 ¹ / ₈	2
		65	28	51
1½" PEX x 1½" NPT	Q5571515	2 ⁷ / ₈	1 ¹ / ₈	2 ¹ / ₄
		73	29	57
	LF4571515	2 ⁷ / ₈	1 ¹ / ₈	2 ¹ / ₄
		73	29	57
2" PEX x 2" NPT	Q5572020	3 ⁹ / ₁₆	1 ¹ / ₈	3
		90	36	76
	LF4572020	3 ⁹ / ₁₆	1 ¹ / ₈	3
		90	36	76

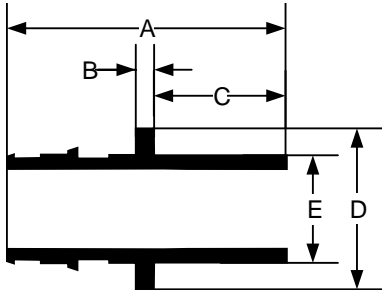

ProPEX brass fitting adapters		A	B	C	D	E
Description	Part no.	in/mm	in/mm	in/mm	in/mm	in/mm
½" PEX x ½" copper	LF4505050	1⅝	⅜	9/16	¾	5/8
		35	3	14	20	16
	Q5505050	1⅞	⅜	7/8	¾	5/8
½" PEX x ¾" copper	LF4505075	43	3	22	20	16
		1⅝	⅜	13/16	15/16	7/8
5/8" PEX x ½" copper	Q4506375	42	3	21	23	22
		1⅞	⅜	9/16	11/16	5/8
5/8" PEX x ¾" copper	Q4506375	39	3	14	26	16
		1⅞	⅜	13/16	15/16	7/8
¾" PEX x ½" copper	LF4507550	46	3	21	24	22
		1⅝	⅜	9/16	1⅝	5/8
	Q5507550	41	3	14	28	16
¾" PEX x ¾" copper	LF4507575	1⅞	⅜	7/8	1⅝	5/8
		48	3	21	28	22
	Q5507575	2⅞	⅜	1	1⅝	7/8
¾" PEX x 1" copper	LF4507510	53	3	25	28	22
		2⅞	⅜	1	1⅝	7/8
	Q5507510	53	3	25	29	28
1" PEX x 1" copper	LF4501010	2⅞	⅜	1	1⅝	1⅝
		58	3	25	35	29
	Q5501010	2⅞	⅜	1	1⅝	1⅝
1¼" PEX x 1¼" copper	LF4501313	59	3	25	35	29
		2⅞	⅜	1	1⅝	1⅝
	Q5501313	66	3	25	42	35
1½" PEX x 1½" copper	LF4501515	2⅞	⅜	1	1⅝	1⅝
		69	3	29	44	35
	Q5501515	3	⅜	13/16	1⅝	1⅝
2" PEX x 2" copper	LF4502020	76	3	29	48	41
		3⅝	⅜	13/16	1⅝	1⅝
	LF4502020	86	3	40	48	41
2" PEX x 2" copper	LF4502020	3⅞	¼	17/16	2⅝	2⅝
		97	6	36	66	54
	LF4502020	4⅞	¼	1¾	2⅞	2⅝
		105	6	44	68	54

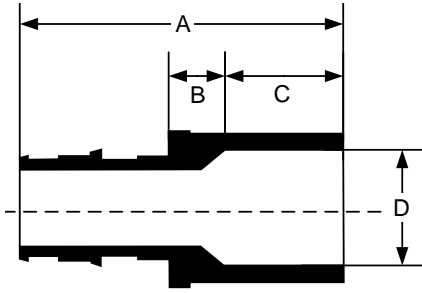

ProPEX brass sweat adapters		A	B	C	D
Description	Part no.	in/mm	in/mm	in/mm	in/mm
3/8" PEX x 1/2" copper	LF4513850	1 5/16	1/4	1/2	5/8
		34	6	13	16
1/2" PEX x 1/2" copper	LF4515050	1 3/8	3/16	1/2	5/8
		35	5	13	16
	Q5515050	1 3/8	3/16	1/2	5/8
		35	5	13	16
1/2" PEX x 3/4" copper	LF4515075	1 5/8	3/16	3/4	7/8
		41	5	19	22
3/4" PEX x 1/2" copper	LF4517550	1 11/16	1/4	1/2	5/8
		42	6	13	16
	Q5517550	1 11/16	1/4	1/2	5/8
		42	6	13	16
3/4" PEX x 3/4" copper	LF4517575	1 7/8	3/16	3/4	7/8
		47	5	19	22
	Q5517575	1 7/8	3/16	3/4	7/8
		47	5	19	22
3/4" PEX x 1" copper	LF4517510	2 1/8	1/4	1 5/16	1 1/8
		53	6	23	29
	Q5517510	2 1/8	1/4	1 5/16	1 1/8
		53	6	23	29
1" PEX x 1" copper	LF4511010	2 1/4	3/16	1 5/16	1 1/8
		58	5	23	29
	Q5511010	2 1/4	3/16	1 5/16	1 1/8
		58	5	23	29
1 1/4" PEX x 1 1/4" copper	LF4511313	2 5/8	3/16	1	1 3/8
		66	5	25	33
	Q5511313	2 5/8	3/16	1	1 3/8
		66	5	25	33
1 1/2" PEX x 1 1/2" copper	LF4511515	3 3/16	1/4	1 1/16	1 5/8
		78	6	28	41
	Q5511515	3 3/16	1/4	1 1/16	1 5/8
		78	6	28	41
2" PEX x 2" copper	LF4512020	3 3/4	1/4	1 5/16	2 1/8
		95	6	34	54
	Q5512020	3 3/4	1/4	1 5/16	2 1/8
		95	6	34	54
2 1/2" PEX x 2 1/2" copper	LF4512525	4 1/16	5/16	1 7/16	2 5/8
		116	8	37	67
3" PEX x 3" copper	LF4513030	5 1/16	3/16	1 11/16	3 1/8
		135	8	42	80

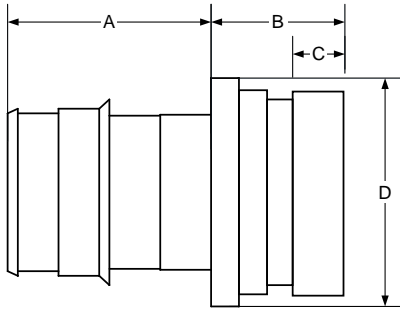

ProPEX LF brass groove fitting adapters		A	B	C	D
Description	Part no.	in/mm	in/mm	in/mm	in/mm
2" PEX x 2" CTS groove	LFV2962020	2 ¹ / ₈	1 ¹ / ₂	5/ ₈	2 ¹¹ / ₁₆
		54	38	15	68
2" PEX x 2 ¹ / ₂ " CTS groove	LFV2962025	2 ¹ / ₈	1 ¹ / ₂	5/ ₈	2 ¹¹ / ₁₆
		54	38	15	68
2 ¹ / ₂ " PEX x 2 ¹ / ₂ " CTS groove	LFV2962525	2 ⁹ / ₁₆	1 ¹ / ₂	5/ ₈	3 ³ / ₈
		72	38	15	85
3" PEX x 3" CTS groove	LFV2963030	3 ³ / ₈	1 ¹ / ₂	5/ ₈	3 ¹⁹ / ₁₆
		86	38	15	96
2" PEX x 2" IPS groove	LFV2972020	2 ¹ / ₈	1 ¹ / ₂	5/ ₈	2 ¹¹ / ₁₆
		54	38	15	68
2" PEX x 2 ¹ / ₂ " IPS groove	LFV2972025	2 ¹ / ₈	1 ¹ / ₂	5/ ₈	2 ⁷ / ₈
		54	38	15	73
2 ¹ / ₂ " PEX x 2" IPS groove	LFV2972520	2 ⁹ / ₁₆	1 ¹ / ₂	5/ ₈	3 ³ / ₈
		72	38	15	85
2 ¹ / ₂ " PEX x 2 ¹ / ₂ " IPS groove	LFV2972525	2 ⁹ / ₁₆	1 ¹ / ₂	5/ ₈	3 ³ / ₈
		72	38	15	85
2 ¹ / ₂ " PEX x 3" IPS groove	LFV2972530	2 ⁹ / ₁₆	1 ¹ / ₂	5/ ₈	3 ¹ / ₂
		72	38	15	89
3" PEX x 2 ¹ / ₂ " IPS groove	LFV2973025	3 ³ / ₈	1 ¹ / ₂	5/ ₈	3 ¹⁹ / ₁₆
		86	38	15	96
3" PEX x 3" IPS groove	LFV2973030	3 ³ / ₈	1 ¹ / ₂	5/ ₈	3 ¹⁹ / ₁₆
		86	38	15	96

ProPEX LF brass flange adapter		A	B	C	D
Description	Part no.	in/mm	in/mm	in/mm	in/mm
2 ¹ / ₂ " PEX x flange	LF2982525	3 ³ / ₄	5/ ₈	2 ¹⁹ / ₁₆	7
		96	16	72	178
3" PEX x flange	LF2983030	4 ⁵ / ₁₆	5/ ₈	4 ¹ / ₁₆	7 ¹ / ₂
		110	16	104	191

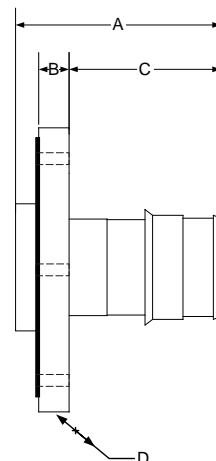

ProPEX EP opposing-port tees		A	B	C	D
Description	Part no.	in/mm	in/mm	in/mm	in/mm
1" PEX x 1" PEX x 3/4" PEX x 3/4" PEX	Q4801075	1 1/16	15/16	2 1/16	1 5/8
		30	24	53	41
1 1/4" PEX x 1 1/4" PEX x 3/4" PEX x 3/4" PEX	Q4801375	1 7/16	15/16	2 3/8	1 3/4
		37	24	60	44
1 1/2" PEX x 1 1/2" PEX x 3/4" PEX x 3/4" PEX	Q4801575	1 11/16	15/16	2 11/16	1 15/16
		43	24	69	49
2" PEX x 2" PEX x 3/4" PEX x 3/4" PEX	Q4802075	2 3/16	15/16	3 3/16	2
		55	24	81	51

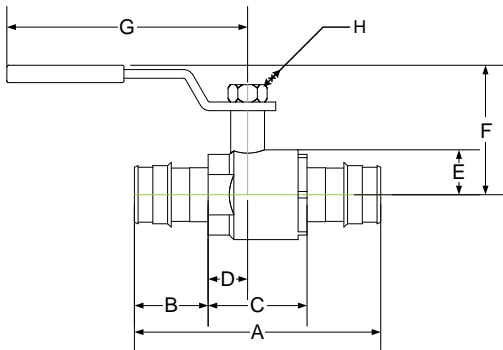
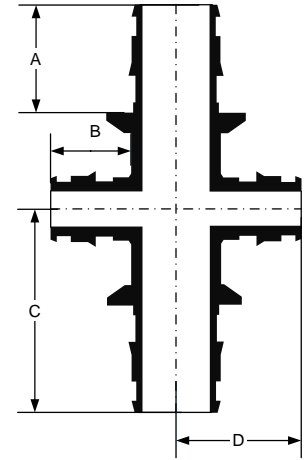

ProPEX brass ball valves		A	B	C	D	E	F	G	H
Description	Part no.	in/mm	in/mm	in/mm	in/mm	in/mm	in/mm	in/mm	in/mm
1/2" PEX x 1/2" PEX	A3205050	2 1/2	1 1/16	1 1/16	3/8	1/2	1 1/16	3 3/8	3/8
		64	18	27	10	12	43	84	10
	LFC4825050	2 1/2	1 1/16	1 1/16	3/8	1/2	1 1/16	3 3/8	3/8
		64	18	27	10	12	43	84	10
3/4" PEX x 3/4" PEX	A3207575	3 3/8	15/16	1 1/2	1/2	1/2	1 7/8	3 3/8	3/8
		86	24	38	12	12	47	85	10
	LFC4827575	3 3/8	15/16	1 1/2	1/2	1/2	1 7/8	3 3/8	3/8
		86	24	38	12	12	47	85	10
1" PEX x 1" PEX	A3201010	4 3/16	1 3/16	1 13/16	3/4	13/16	1 7/8	4 7/16	1/2
		106	30	46	18	20	48	114	12
	LFC4821010	4 3/16	1 3/16	1 13/16	3/4	13/16	1 7/8	4 7/16	1/2
		106	30	46	18	20	48	114	12
1 1/4" PEX x 1 1/4" PEX	A3201313	4 13/16	1 7/16	1 15/16	5/8	15/16	2 1/4	4 7/16	1/2
		122	37	49	17	24	58	114	12
	LFC4821313	4 13/16	1 7/16	1 15/16	5/8	15/16	2 1/4	4 7/16	1/2
		122	37	49	17	24	58	114	12
1 1/2" PEX x 1 1/2" PEX	A3201515	5 11/16	1 11/16	2 1/8	19/16	1 1/8	2 11/16	5 9/16	9/16
		145	43	58	23	28	69	142	14
	LFC4821515	5 11/16	1 11/16	2 1/8	19/16	1 1/8	2 11/16	5 9/16	9/16
		145	43	58	23	28	69	142	14
2" PEX x 2" PEX	A3202020	7 1/8	2 1/8	2 13/16	1 1/8	1 7/16	3 3/8	5 9/16	9/16
		181	55	72	28	37	86	142	14
	LFC4822020	7 1/8	2 1/8	2 13/16	1 1/8	1 7/16	3 3/8	5 9/16	9/16
		181	55	72	28	37	86	142	14

ProPEX ring installed diameter		A
Description	Part no.	in/mm
½" ProPEX Ring with Stop	Q4690512	1 ⁵ / ₁₆
		24
¾" ProPEX Ring with Stop	Q4690756	1¼
		32
1" ProPEX Ring with Stop	Q4691000	1 ⁹ / ₁₆
		40
1¼" ProPEX Ring with Stop	Q4691250	1 ¹³ / ₁₆
		47
1½" ProPEX Ring with Stop	Q4691500	2 ¹ / ₁₆
		53
2" ProPEX Ring with Stop	Q4692000	2 ⁹ / ₁₆
		74
2½" ProPEX Ring with Stop	Q4692500	3 ³ / ₁₆
		91
3" ProPEX Ring with Stop	Q4693000	4¼
		108

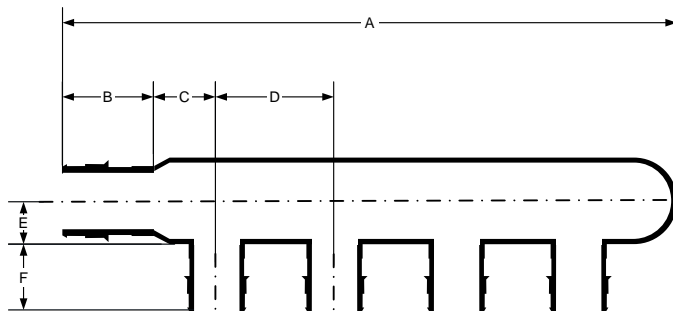
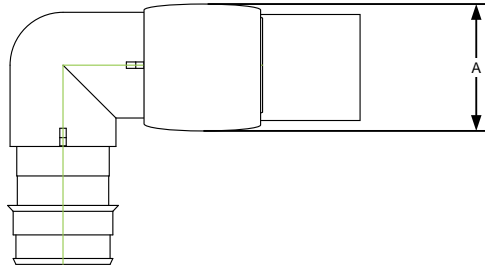

EP branch multiport tees		A	B	C	D	E	F
Description	Part no.	in/mm	in/mm	in/mm	in/mm	in/mm	in/mm
¾" EP Branch Multiport Tee, 3 outlets	Q2237550	5 ⁵ / ₈	1 ⁵ / ₁₆	5 ⁵ / ₈	1¼	7 ⁷ / ₁₆	¾
		131	24	16	32	12	18
1¼" EP Branch Multiport Tee, 3 outlets	Q2231375	6 ⁷ / ₈	1 ⁷ / ₁₆	7 ⁷ / ₈	1¾	1 ¹ / ₁₆	1 ⁵ / ₁₆
		174	37	23	44	18	24
¾" EP Branch Multiport Tee, 4 outlets	Q2247550	6 ³ / ₈	1 ⁵ / ₁₆	5 ⁵ / ₈	1¼	7 ⁷ / ₁₆	¾
		163	24	16	32	12	18
1" EP Branch Multiport Tee, 4 outlets	Q2241050	6 ¹¹ / ₁₆	1 ³ / ₁₆	1 ³ / ₁₆	1¼	5 ⁵ / ₈	¾
		170	30	21	32	15	18
¾" EP Branch Multiport Tee, 6 outlets	Q2267550	8 ⁷ / ₈	1 ⁵ / ₁₆	5 ⁵ / ₈	1¼	7 ⁷ / ₁₆	¾
		226	24	16	32	12	18
1" EP Branch Multiport Tee, 6 outlets	Q2261050	9¼	1 ³ / ₁₆	5 ⁵ / ₈	1¼	9 ⁹ / ₁₆	¾
		235	30	16	32	14	18

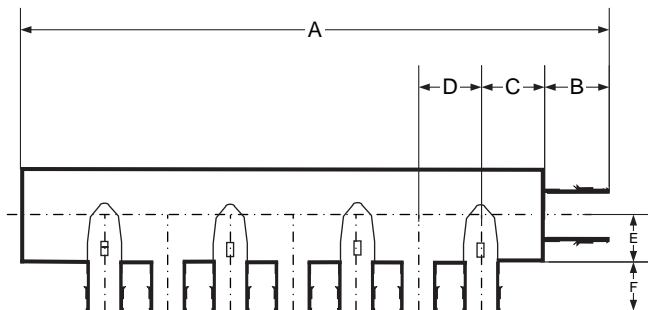

Commercial EP branch multiport tees		A	B	C	D	E	F
Description	Part no.	in/mm	in/mm	in/mm	in/mm	in/mm	in/mm
3/4" EP Branch Multiport Tee, 7 outlets	Q2277550	8 ¹ / ₁₆	1 ⁵ / ₁₆	1 ¹ / ₈	7 ⁷ / ₈	1 ¹ / ₁₆	3/4
		220	24	28	23	18	18
3/4" EP Branch Multiport Tee, 8 outlets	Q2287550	9 ⁹ / ₁₆	1 ⁵ / ₁₆	1 ¹ / ₈	7 ⁷ / ₈	1 ¹ / ₁₆	3/4
		243	24	28	23	18	18
1" EP Branch Multiport Tee, 7 outlets	Q2271051	8 ⁷ / ₈	1 ³ / ₁₆	1 ¹ / ₈	7 ⁷ / ₈	1 ¹ / ₁₆	3/4
		226	30	28	23	18	18
1" EP Branch Multiport Tee, 8 outlets	Q2281051	9 ⁹ / ₁₆	1 ³ / ₁₆	1 ¹ / ₈	7 ⁷ / ₈	1 ¹ / ₁₆	3/4
		249	30	28	23	18	18
1" EP Branch Multiport Tee, 10 outlets	Q2101051	11 ⁹ / ₁₆	1 ³ / ₁₆	1 ¹ / ₈	7 ⁷ / ₈	1 ¹ / ₁₆	3/4
		294	30	28	23	18	18
1" EP Branch Multiport Tee, 12 outlets	Q2121051	13 ³ / ₈	1 ³ / ₁₆	1 ¹ / ₈	7 ⁷ / ₈	1 ¹ / ₁₆	3/4
		340	30	28	23	18	18

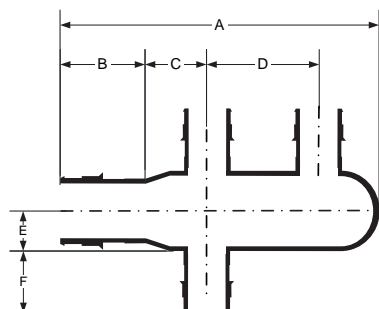

EP branch opposing-port multiport tees		A	B	C	D	E	F
Description	Part no.	in/mm	in/mm	in/mm	in/mm	in/mm	in/mm
3/4" EP Branch Opposing-port Multiport Tee, 3 outlets	Q2337550	3 ³ / ₁₆	1 ⁵ / ₁₆	5 ⁵ / ₈	1 ¹ / ₄	7 ⁷ / ₁₆	3/4
		91	24	16	32	11	18
3/4" EP Branch Opposing-port Multiport Tee, 4 outlets	Q2347550	3 ³ / ₁₆	1 ⁵ / ₁₆	5 ⁵ / ₈	1 ¹ / ₄	7 ⁷ / ₁₆	3/4
		91	24	16	32	11	18
3/4" EP Branch Opposing-port Multiport Tee, 8 outlets	Q2387550	6 ¹ / ₁₆	1 ⁵ / ₁₆	5 ⁵ / ₈	1 ¹ / ₄	7 ⁷ / ₁₆	3/4
		154	24	16	32	11	18

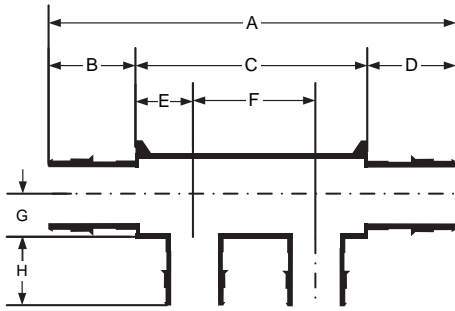

EP flow-through multiport tees		A	B	C	D	E	F	G	H
Description	Part no.	in/mm	in/mm	in/mm	in/mm	in/mm	in/mm	in/mm	in/mm
2 outlets, 3/4" x 3/4"	Q2227557	4 3/8	1 5/16	2 1/2	1 5/16	5/8	1 1/4	7/16	3/4
		112	24	64	24	16	32	11	19
3 outlets, 3/4" x 3/4"	Q2237557	5 11/16	1 5/16	3 3/4	1 5/16	5/8	1 1/4	7/16	3/4
		143	24	95	24	16	32	11	19
3 outlets, 1" x 3/4"	Q2231057	6 3/16	1 3/16	4 1/16	1 5/16	3/4	1 1/4	9/16	3/4
		157	30	103	24	19	32	14	19
3 outlets, 1 3/4" x 1 1/4"	Q2231373	8 3/16	1 7/16	5 5/16	1 7/16	7/8	1 3/4	5/8	1
		208	37	135	37	23	44	17	25
3 outlets, 2" x 2"	Q2232102	10 5/8	2 3/16	6 1/4	2 3/16	1 1/8	2	1 5/16	1 5/16
		269	55	158	55	28	51	24	33
4 outlets, 3/4" x 3/4"	Q2247557	7 1/16	1 5/16	5 7/8	1 5/16	1 1/16	1 1/2	7/16	3/4
		198	24	150	24	18	38	11	18
4 outlets, 1" x 3/4"	Q2241057	7 1/8	1 3/16	5	1 5/16	5/8	1 1/4	9/16	3/4
		180	30	127	24	16	32	14	19
4 outlets, 1" x 1"	Q2241051	7 11/16	1 3/16	5 5/16	1 3/16	3/4	1 1/4	9/16	3/4
		195	30	135	30	19	32	14	19
6 outlets, 3/4" x 3/4"	Q2267557	9 3/8	1 5/16	7 1/2	1 5/16	5/8	1 1/4	7/16	3/4
		239	24	191	24	16	32	11	19
6 outlets, 1" x 3/4"	Q2261057	9 5/8	1 3/16	7 1/2	1 5/16	5/8	1 1/4	9/16	3/4
		244	30	191	24	16	32	14	19
6 outlets, 1" x 1"	Q2261051	9 7/8	1 3/16	7 1/2	1 3/16	5/8	1 1/4	9/16	3/4
		251	30	191	30	16	32	14	19

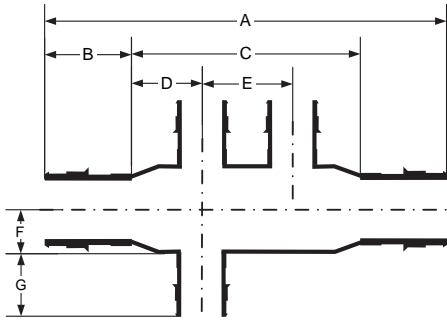

EP flow-through opposing-port multiport tees		A	B	C	D	E	F	G
Description	Part no.	in/mm	in/mm	in/mm	in/mm	in/mm	in/mm	in/mm
3 outlets, 3/4" x 3/4"	Q2337557	4 ⁷ / ₁₆	1 ⁵ / ₁₆	2 1/2	5/8	1 1/4	1/2	3/4
		112	24	63	16	32	12	18
4 outlets, 3/4" x 3/4"	Q2347557	4 ⁷ / ₁₆	1 ⁵ / ₁₆	2 1/2	5/8	1 1/4	1/2	3/4
		112	24	63	16	32	12	19
6 outlets, 3/4" x 3/4"	Q2367557	5 ¹¹ / ₁₆	1 ⁵ / ₁₆	3 3/4	5/8	1 1/4	1/2	3/4
		144	24	95	16	32	12	19

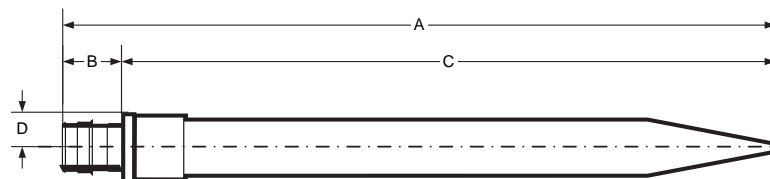

ProPEX LF copper straight stubs		A	B	C	D
Description	Part no.	in/mm	in/mm	in/mm	in/mm
1/2" PEX LF brass x 1/2" copper, 8"	LF2935050	8 ⁵ / ₁₆	1 ¹ / ₁₆	7 ⁷ / ₁₆	3/8
		211	18	193	10
1/2" PEX LF brass x 1/2" copper, 15"	LF2945050	14 1/2	1 ¹ / ₁₆	13 ¹³ / ₁₆	3/8
		368	18	350	10
2 1/2" PEX LF brass x 2 1/2" copper	LF2962525	12 ¹ / ₈	2 ¹³ / ₁₆	9 1/4	1 ¹³ / ₁₆
		308	72	236	46
3" PEX LF brass x 3" copper	LF2963030	13 ¹¹ / ₁₆	3 ³ / ₈	10 ⁹ / ₁₆	2 1/8
		347	86	261	53

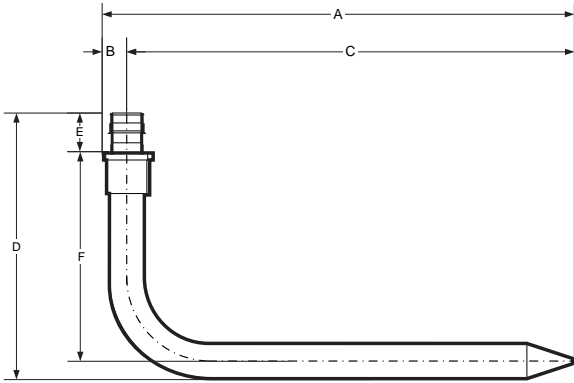

ProPEX LF copper stub ells		A	B	C	D	E	F
Description	Part no.	in/mm	in/mm	in/mm	in/mm	in/mm	in/mm
1/2" PEX LF brass x 1/2" copper, 3 1/2" x 8"	LF2865050	8 3/8	3/8	8	4 3/4	1 1/16	3 3/4
		213	10	203	121	18	95
1/2" PEX LF brass x 1/2" copper, 13" x 8"	LF2855050	8 3/8	3/8	8	13 5/16	1 1/16	12 5/16
		213	10	203	338	18	312
1/2" PEX LF brass x 1/2" copper, 8" x 13"	LF2895050	13 3/8	3/8	13	13 5/16	1 1/16	7 5/16
		340	10	330	338	18	185
3/4" PEX LF brass x 3/4" copper, 4" x 8"	LF2897575	8 9/16	9/16	8	5 7/16	1 5/16	4 1/16
		217	14	203	138	24	103
1" PEX LF brass x 1" copper, 12" x 12"	LF2891010	13 11/16	1 1/16	13	16	1 3/16	14 1/4
		347	17	330	406	30	362

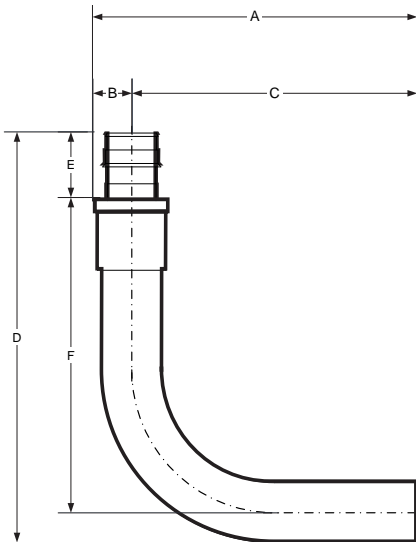

ProPEX LF copper tub ells		A	B	C	D	E	F
Description	Part no.	in/mm	in/mm	in/mm	in/mm	in/mm	in/mm
1/2" PEX LF brass x 1/2" copper, 3" x 6"	LF2875050	3 3/8	3/8	3	6 9/16	1 1/16	5 1/4
		86	10	76	160	18	134
1/2" PEX LF brass x 1/2" copper, 3" x 4"	LF2885050	3 3/8	3/8	3	4 9/16	1 1/16	3 1/4
		86	10	76	109	18	83

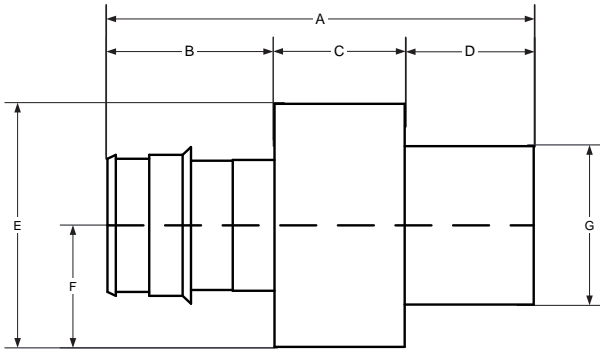

ProPEX LF brass CPVC spigot adapters		A	B	C	D	E	F	G
Description	Part no.	in/mm	in/mm	in/mm	in/mm	in/mm	in/mm	in/mm
1¼" PEX x 1¼" CPVC (CTS)	CP4501313	3 ¹¹ / ₁₆	1 ⁷ / ₁₆	1 ¹ / ₈	1 ¹ / ₈	2 ¹ / ₈	1 ¹ / ₁₆	1 ³ / ₈
		94	37	29	29	54	27	35
1½" PEX x 1½" CPVC (CTS)	CP4501515	4 ³ / ₁₆	1 ¹¹ / ₁₆	1 ³ / ₁₆	1 ⁵ / ₁₆	2 ³ / ₈	1 ³ / ₁₆	1 ⁵ / ₈
		107	43	30	34	61	30	41
2" PEX x 2" CPVC (CTS)	CP4502020	5 ³ / ₁₆	2 ³ / ₁₆	1 ¹ / ₈	1 ³ / ₄	3	1 ¹ / ₂	2 ¹ / ₈
		134	55	36	44	76	38	54

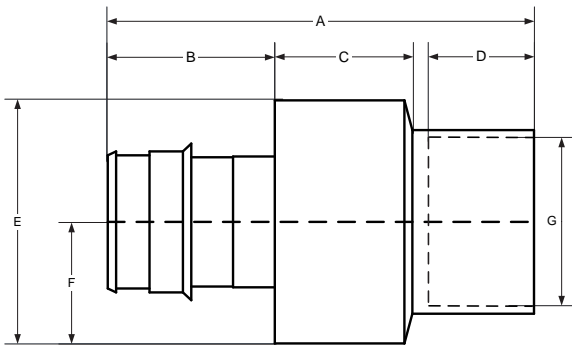

ProPEX LF brass CPVC socket adapters		A	B	C	D	E	F	G
Description	Part no.	in/mm	in/mm	in/mm	in/mm	in/mm	in/mm	in/mm
1¼" PEX x 1¼" CPVC (CTS)	CP4511313	3 ¹¹ / ₁₆	1 ⁷ / ₁₆	1 ¹ / ₄	1	2 ¹ / ₈	1 ¹ / ₁₆	1 ³ / ₈
		94	37	31	26	54	27	35
1½" PEX x 1½" CPVC (CTS)	CP4511515	4 ³ / ₁₆	1 ¹¹ / ₁₆	1 ¹ / ₄	1 ¹ / ₁₆	2 ¹ / ₈	1 ¹ / ₁₆	1 ³ / ₈
		106	43	32	33	61	30	42
2" PEX x 2" CPVC (CTS)	CP4512020	5 ³ / ₁₆	2 ³ / ₁₆	1 ³ / ₈	2	3	1 ¹ / ₂	2 ¹ / ₈
		133	55	38	43	76	38	54

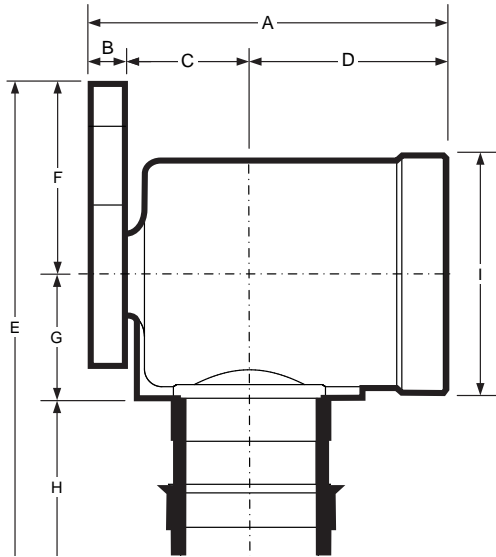

ProPEX LF brass drop ear elbow		A	B	C	D	E	F	G	H	I
Description	Part no.	in/mm	in/mm	in/mm	in/mm	in/mm	in/mm	in/mm	in/mm	in/mm
½" PEX x ½" FIP	LF4235050	1 ¹ / ₁₆	¼	7 ⁷ / ₁₆	1	2 ³ / ₁₆	1	9 ⁹ / ₁₆	1 ¹ / ₁₆	1 ¹ / ₁₆
		43	6	11	26	56	26	14	18	26
¾" PEX x ¾" FIP	LF4237575	1 ¹⁵ / ₁₆	¼	¾	1	2 ³ / ₁₆	1 ³ / ₁₆	1 ¹ / ₁₆	1 ⁵ / ₁₆	1 ³ / ₈
		49	6	18	26	71	29	17	24	35
1" PEX x ¾" FIP	LF4231010	2 ⁷ / ₁₆	¼	7 ⁷ / ₈	1¼	3 ⁵ / ₁₆	1 ⁵ / ₁₆	7 ⁷ / ₈	1 ³ / ₁₆	1 ⁵ / ₈
		62	6	22	33	84	33	22	30	42

Appendix E:

Expansion arm and loop calculations

Thermal expansion in underground applications

For direct-burial applications, mitigate the effects of thermal expansion with a proper installation that provides adequate resistance to axial

stress. Per PPI TR-21 *Thermal Expansion and Contraction in Plastics Piping Systems*, restrain a buried or concrete-encased pipe from both lateral and axial movement with surrounding embedment material. The magnitude of the frictional restraining force

is dependent on the nature of the soil and on installation and operating conditions.

For example, the extent of compaction near the pipe can affect the quality of contact between the pipe and surrounding soil. The

anchoring or restraining effect of surrounding soil on pipe movement can be significantly augmented by external pipe geometry. Tees, lateral connections and changes in direction all help to anchor a pipe in the surrounding soil.

PEX with PEX-a Pipe Support, strut and strut clamps

has a thermal expansion rate of 0.08"/10°F ΔT/100 ft. (2.03mm/5.56°C ΔT/30.48m)

½" PEX pipe expansion arm

	Delta T (ΔT)	Run (ft)	Delta L (in)	Flexible arm length (in)	L1 (in)	L2 (in)
PEX with PEX-a Pipe Support, strut and strut clamps has a thermal expansion rate of 0.08"/10°F ΔT/100 ft. (2.03mm/5.56°C ΔT/30.48m).	10	50	0.04	1.90	0.38	0.76
		60	0.048	2.08	0.42	0.83
		70	0.056	2.24	0.45	0.90
		80	0.064	2.40	0.48	0.96
		90	0.072	2.55	0.51	1.02
		100	0.08	2.68	0.54	1.07
	20	50	0.08	2.68	0.54	1.07
		60	0.096	2.94	0.59	1.18
		70	0.112	3.17	0.63	1.27
		80	0.128	3.39	0.68	1.36
		90	0.144	3.60	0.72	1.44
	30	50	0.12	3.29	0.66	1.31
		60	0.144	3.60	0.72	1.44
		70	0.168	3.89	0.78	1.56
		80	0.192	4.16	0.83	1.66
		90	0.216	4.41	0.88	1.76
	40	50	0.16	3.79	0.76	1.52
		60	0.192	4.16	0.83	1.66
		70	0.224	4.49	0.90	1.80
		80	0.256	4.80	0.96	1.92
90		0.288	5.09	1.02	2.04	
		100	0.32	5.37	1.07	2.15

½" PEX pipe expansion arm

	Delta T (ΔT)	Run (ft)	Delta L (in)	Flexible arm length (in)	L1 (in)	L2 (in)
PEX with PEX-a Pipe Support, strut and strut clamps has a thermal expansion rate of 0.08"/10°F ΔT/100 ft. (2.03mm/5.56°C ΔT/30.48m).	50	50	0.2	4.24	0.85	1.70
		60	0.24	4.65	0.93	1.86
		70	0.28	5.02	1.00	2.01
		80	0.32	5.37	1.07	2.15
		90	0.36	5.69	1.14	2.28
		100	0.4	6.00	1.20	2.40
	60	50	0.24	4.65	0.93	1.86
		60	0.288	5.09	1.02	2.04
		70	0.336	5.50	1.10	2.20
		80	0.384	5.88	1.18	2.35
		90	0.432	6.24	1.25	2.49
	70	50	0.28	5.02	1.00	2.01
		60	0.336	5.50	1.10	2.20
		70	0.392	5.94	1.19	2.38
		80	0.448	6.35	1.27	2.54
		90	0.504	6.73	1.35	2.69
	80	50	0.32	5.37	1.07	2.15
		60	0.384	5.88	1.18	2.35
		70	0.448	6.35	1.27	2.54
		80	0.512	6.79	1.36	2.72
90		0.576	7.20	1.44	2.88	
		100	0.64	7.59	1.52	3.04

Table E-1: PEX pipe expansion arm calculations ½" to 3"

½" PEX pipe expansion arm

PEX with PEX-a Pipe Support, strut and strut clamps has a thermal expansion rate of 0.08"/10°F ΔT/100 ft. (2.03mm/5.56°C ΔT/30.48m).

Delta T (ΔT)	Run (ft)	Delta L (in)	Flexible arm length (in)	L1 (in)	L2 (in)
90	50	0.36	5.69	1.14	2.28
	60	0.432	6.24	1.25	2.49
	70	0.504	6.73	1.35	2.69
	80	0.576	7.20	1.44	2.88
	90	0.648	7.64	1.53	3.05
	100	0.72	8.05	1.61	3.22
100	50	0.4	6.00	1.20	2.40
	60	0.48	6.57	1.31	2.63
	70	0.56	7.10	1.42	2.84
	80	0.64	7.59	1.52	3.04
	90	0.72	8.05	1.61	3.22
	100	0.8	8.49	1.70	3.39
110	50	0.44	6.29	1.26	2.52
	60	0.528	6.89	1.38	2.76
	70	0.616	7.45	1.49	2.98
	80	0.704	7.96	1.59	3.18
	90	0.792	8.44	1.69	3.38
	100	0.88	8.90	1.78	3.56
120	50	0.48	6.57	1.31	2.63
	60	0.576	7.20	1.44	2.88
	70	0.672	7.78	1.56	3.11
	80	0.768	8.31	1.66	3.33
	90	0.864	8.82	1.76	3.53
	100	0.96	9.30	1.86	3.72
130	50	0.52	6.84	1.37	2.74
	60	0.624	7.49	1.50	3.00
	70	0.728	8.09	1.62	3.24
	80	0.832	8.65	1.73	3.46
	90	0.936	9.18	1.84	3.67
	100	1.04	9.67	1.93	3.87
140	50	0.56	7.10	1.42	2.84
	60	0.672	7.78	1.56	3.11
	70	0.784	8.40	1.68	3.36
	80	0.896	8.98	1.80	3.59
	90	1.008	9.52	1.90	3.81
	100	1.12	10.04	2.01	4.02
150	50	0.6	7.35	1.47	2.94
	60	0.72	8.05	1.61	3.22
	70	0.84	8.69	1.74	3.48
	80	0.96	9.30	1.86	3.72
	90	1.08	9.86	1.97	3.94
	100	1.2	10.39	2.08	4.16

½" PEX pipe expansion arm

PEX with PEX-a Pipe Support, strut and strut clamps has a thermal expansion rate of 0.08"/10°F ΔT/100 ft. (2.03mm/5.56°C ΔT/30.48m).

Delta T (ΔT)	Run (ft)	Delta L (in)	Flexible arm length (in)	L1 (in)	L2 (in)
160	50	0.64	7.59	1.52	3.04
	60	0.768	8.31	1.66	3.33
	70	0.896	8.98	1.80	3.59
	80	1.024	9.60	1.92	3.84
	90	1.152	10.18	2.04	4.07
	100	1.28	10.73	2.15	4.29

¾" PEX pipe expansion arm

PEX with PEX-a Pipe Support, strut and strut clamps has a thermal expansion rate of 0.08"/10°F ΔT/100 ft. (2.03mm/5.56°C ΔT/30.48m).

Delta T (ΔT)	Run (ft)	Delta L (in)	Flexible arm length (in)	L1 (in)	L2 (in)
10	50	0.04	2.24	0.45	0.90
	60	0.048	2.46	0.49	0.98
	70	0.056	2.66	0.53	1.06
	80	0.064	2.84	0.57	1.14
	90	0.072	3.01	0.60	1.20
	100	0.08	3.17	0.63	1.27
20	50	0.08	3.17	0.63	1.27
	60	0.096	3.48	0.70	1.39
	70	0.112	3.76	0.75	1.50
	80	0.128	4.02	0.80	1.61
	90	0.144	4.26	0.85	1.70
	100	0.16	4.49	0.90	1.80
30	50	0.12	3.89	0.78	1.56
	60	0.144	4.26	0.85	1.70
	70	0.168	4.60	0.92	1.84
	80	0.192	4.92	0.98	1.97
	90	0.216	5.22	1.04	2.09
	100	0.24	5.50	1.10	2.20
40	50	0.16	4.49	0.90	1.80
	60	0.192	4.92	0.98	1.97
	70	0.224	5.31	1.06	2.13
	80	0.256	5.68	1.14	2.27
	90	0.288	6.02	1.20	2.41
	100	0.32	6.35	1.27	2.54
50	50	0.2	5.02	1.00	2.01
	60	0.24	5.50	1.10	2.20
	70	0.28	5.94	1.19	2.38
	80	0.32	6.35	1.27	2.54
	90	0.36	6.73	1.35	2.69
	100	0.4	7.10	1.42	2.84

Table E-1: PEX pipe expansion arm calculations ½" to 3"

¾" PEX pipe expansion arm

PEX with PEX-a Pipe Support, strut and strut clamps has a thermal expansion rate of 0.08"/10°F ΔT/100 ft. (2.03mm/5.56°C ΔT/30.48m).

Delta T (ΔT)	Run (ft)	Delta L (in)	Flexible arm length (in)	L1 (in)	L2 (in)
60	50	0.24	5.50	1.10	2.20
	60	0.288	6.02	1.20	2.41
	70	0.336	6.51	1.30	2.60
	80	0.384	6.96	1.39	2.78
	90	0.432	7.38	1.48	2.95
	100	0.48	7.78	1.56	3.11
70	50	0.28	5.94	1.19	2.38
	60	0.336	6.51	1.30	2.60
	70	0.392	7.03	1.41	2.81
	80	0.448	7.51	1.50	3.01
	90	0.504	7.97	1.59	3.19
	100	0.56	8.40	1.68	3.36
80	50	0.32	6.35	1.27	2.54
	60	0.384	6.96	1.39	2.78
	70	0.448	7.51	1.50	3.01
	80	0.512	8.03	1.61	3.21
	90	0.576	8.52	1.70	3.41
	100	0.64	8.98	1.80	3.59
90	50	0.36	6.73	1.35	2.69
	60	0.432	7.38	1.48	2.95
	70	0.504	7.97	1.59	3.19
	80	0.576	8.52	1.70	3.41
	90	0.648	9.04	1.81	3.61
	100	0.72	9.52	1.90	3.81
100	50	0.4	7.10	1.42	2.84
	60	0.48	7.78	1.56	3.11
	70	0.56	8.40	1.68	3.36
	80	0.64	8.98	1.80	3.59
	90	0.72	9.52	1.90	3.81
	100	0.8	10.04	2.01	4.02
110	50	0.44	7.45	1.49	2.98
	60	0.528	8.16	1.63	3.26
	70	0.616	8.81	1.76	3.52
	80	0.704	9.42	1.88	3.77
	90	0.792	9.99	2.00	4.00
	100	0.88	10.53	2.11	4.21
120	50	0.48	7.78	1.56	3.11
	60	0.576	8.52	1.70	3.41
	70	0.672	9.20	1.84	3.68
	80	0.768	9.84	1.97	3.93
	90	0.864	10.43	2.09	4.17
	100	0.96	11.00	2.20	4.40

¾" PEX pipe expansion arm

PEX with PEX-a Pipe Support, strut and strut clamps has a thermal expansion rate of 0.08"/10°F ΔT/100 ft. (2.03mm/5.56°C ΔT/30.48m).

Delta T (ΔT)	Run (ft)	Delta L (in)	Flexible arm length (in)	L1 (in)	L2 (in)
130	50	0.52	8.09	1.62	3.24
	60	0.624	8.87	1.77	3.55
	70	0.728	9.58	1.92	3.83
	80	0.832	10.24	2.05	4.10
	90	0.936	10.86	2.17	4.34
	100	1.04	11.45	2.29	4.58
140	50	0.56	8.40	1.68	3.36
	60	0.672	9.20	1.84	3.68
	70	0.784	9.94	1.99	3.98
	80	0.896	10.63	2.13	4.25
	90	1.008	11.27	2.25	4.51
	100	1.12	11.88	2.38	4.75
150	50	0.6	8.69	1.74	3.48
	60	0.72	9.52	1.90	3.81
	70	0.84	10.29	2.06	4.12
	80	0.96	11.00	2.20	4.40
	90	1.08	11.67	2.33	4.67
	100	1.2	12.30	2.46	4.92
160	50	0.64	8.98	1.80	3.59
	60	0.768	9.84	1.97	3.93
	70	0.896	10.63	2.13	4.25
	80	1.024	11.36	2.27	4.54
	90	1.152	12.05	2.41	4.82
	100	1.28	12.70	2.54	5.08

1" PEX pipe expansion arm

PEX with PEX-a Pipe Support, strut and strut clamps

Delta T (ΔT)	Run (ft)	Delta L (in)	Flexible arm length (in)	L1 (in)	L2 (in)
10	50	0.04	2.55	0.51	1.02
	60	0.048	2.79	0.56	1.12
	70	0.056	3.01	0.60	1.20
	80	0.064	3.22	0.64	1.29
	90	0.072	3.42	0.68	1.37
	100	0.08	3.60	0.72	1.44
20	50	0.08	3.60	0.72	1.44
	60	0.096	3.94	0.79	1.58
	70	0.112	4.26	0.85	1.70
	80	0.128	4.55	0.91	1.82
	90	0.144	4.83	0.97	1.93
	100	0.16	5.09	1.02	2.04

Table E-1: PEX pipe expansion arm calculations ½" to 3"

1" PEX pipe expansion arm

PEX with PEX-a Pipe Support, strut and strut clamps has a thermal expansion rate of 0.08"/10°F ΔT/100 ft. (2.03mm/5.56°C ΔT/30.48m).

Delta T (ΔT)	Run (ft)	Delta L (in)	Flexible arm length (in)	L1 (in)	L2 (in)
30	50	0.12	4.41	0.88	1.76
	60	0.144	4.83	0.97	1.93
	70	0.168	5.22	1.04	2.09
	80	0.192	5.58	1.12	2.23
	90	0.216	5.92	1.18	2.37
	100	0.24	6.24	1.25	2.49
40	50	0.16	5.09	1.02	2.04
	60	0.048	2.79	0.56	1.12
	70	0.056	3.01	0.60	1.20
	80	0.064	3.22	0.64	1.29
	90	0.072	3.42	0.68	1.37
	100	0.08	3.60	0.72	1.44
50	50	0.2	5.69	1.14	2.28
	60	0.24	6.24	1.25	2.49
	70	0.28	6.73	1.35	2.69
	80	0.32	7.20	1.44	2.88
	90	0.36	7.64	1.53	3.05
	100	0.4	8.05	1.61	3.22
60	50	0.24	6.24	1.25	2.49
	60	0.288	6.83	1.37	2.73
	70	0.336	7.38	1.48	2.95
	80	0.384	7.89	1.58	3.15
	90	0.432	8.37	1.67	3.35
	100	0.48	8.82	1.76	3.53
70	50	0.28	6.73	1.35	2.69
	60	0.336	7.38	1.48	2.95
	70	0.392	7.97	1.59	3.19
	80	0.448	8.52	1.70	3.41
	90	0.504	9.04	1.81	3.61
	100	0.56	9.52	1.90	3.81
80	50	0.32	7.20	1.44	2.88
	60	0.384	7.89	1.58	3.15
	70	0.448	8.52	1.70	3.41
	80	0.512	9.11	1.82	3.64
	90	0.576	9.66	1.93	3.86
	100	0.64	10.18	2.04	4.07
90	50	0.04	2.55	0.51	1.02
	60	0.048	2.79	0.56	1.12
	70	0.056	3.01	0.60	1.20
	80	0.064	3.22	0.64	1.29
	90	0.072	3.42	0.68	1.37
	100	0.08	3.60	0.72	1.44

1" PEX pipe expansion arm

PEX with PEX-a Pipe Support, strut and strut clamps has a thermal expansion rate of 0.08"/10°F ΔT/100 ft. (2.03mm/5.56°C ΔT/30.48m).

Delta T (ΔT)	Run (ft)	Delta L (in)	Flexible arm length (in)	L1 (in)	L2 (in)
100	50	0.08	3.60	0.72	1.44
	60	0.096	3.94	0.79	1.58
	70	0.112	4.26	0.85	1.70
	80	0.128	4.55	0.91	1.82
	90	0.144	4.83	0.97	1.93
	100	0.16	5.09	1.02	2.04
110	50	0.44	8.44	1.69	3.38
	60	0.528	9.25	1.85	3.70
	70	0.616	9.99	2.00	4.00
	80	0.704	10.68	2.14	4.27
	90	0.792	11.33	2.27	4.53
	100	0.88	11.94	2.39	4.78
120	50	0.48	8.82	1.76	3.53
	60	0.576	9.66	1.93	3.86
	70	0.672	10.43	2.09	4.17
	80	0.768	11.15	2.23	4.46
	90	0.864	11.83	2.37	4.73
	100	0.96	12.47	2.49	4.99
130	50	0.52	9.18	1.84	3.67
	60	0.624	10.05	2.01	4.02
	70	0.728	10.86	2.17	4.34
	80	0.832	11.61	2.32	4.64
	90	0.936	12.31	2.46	4.93
	100	1.04	12.98	2.60	5.19
140	50	0.56	9.52	1.90	3.81
	60	0.672	10.43	2.09	4.17
	70	0.784	11.27	2.25	4.51
	80	0.896	12.05	2.41	4.82
	90	1.008	12.78	2.56	5.11
	100	1.12	13.47	2.69	5.39
150	50	0.6	9.86	1.97	3.94
	60	0.72	10.80	2.16	4.32
	70	0.84	11.67	2.33	4.67
	80	0.96	12.47	2.49	4.99
	90	1.08	13.23	2.65	5.29
	100	1.2	13.94	2.79	5.58
160	50	0.64	10.18	2.04	4.07
	60	0.768	11.15	2.23	4.46
	70	0.896	12.05	2.41	4.82
	80	1.024	12.88	2.58	5.15
	90	1.152	13.66	2.73	5.46
	100	1.28	14.40	2.88	5.76

Table E-1: PEX pipe expansion arm calculations ½" to 3"

1¼" PEX pipe expansion arm

PEX with PEX-a Pipe Support, strut and strut clamps has a thermal expansion rate of 0.08"/10°F ΔT/100 ft. (2.03mm/5.56°C ΔT/30.48m).

Delta T (ΔT)	Run (ft)	Delta L (in)	Flexible arm length (in)	L1 (in)	L2 (in)
10	50	0.04	2.81	0.56	1.13
	60	0.048	3.08	0.62	1.23
	70	0.056	3.33	0.67	1.33
	80	0.064	3.56	0.71	1.42
	90	0.072	3.78	0.76	1.51
	100	0.08	3.98	0.80	1.59
20	50	0.08	3.98	0.80	1.59
	60	0.096	4.36	0.87	1.74
	70	0.112	4.71	0.94	1.88
	80	0.128	5.03	1.01	2.01
	90	0.144	5.34	1.07	2.14
	100	0.16	5.63	1.13	2.25
30	50	0.12	4.87	0.97	1.95
	60	0.144	5.34	1.07	2.14
	70	0.168	5.77	1.15	2.31
	80	0.192	6.17	1.23	2.47
	90	0.216	6.54	1.31	2.62
	100	0.24	6.89	1.38	2.76
40	50	0.16	5.63	1.13	2.25
	60	0.192	6.17	1.23	2.47
	70	0.224	6.66	1.33	2.66
	80	0.256	7.12	1.42	2.85
	90	0.288	7.55	1.51	3.02
	100	0.32	7.96	1.59	3.18
50	50	0.2	6.29	1.26	2.52
	60	0.24	6.89	1.38	2.76
	70	0.28	7.45	1.49	2.98
	80	0.32	7.96	1.59	3.18
	90	0.36	8.44	1.69	3.38
	100	0.4	8.90	1.78	3.56
60	50	0.24	6.89	1.38	2.76
	60	0.288	7.55	1.51	3.02
	70	0.336	8.16	1.63	3.26
	80	0.384	8.72	1.74	3.49
	90	0.432	9.25	1.85	3.70
	100	0.48	9.75	1.95	3.90
70	50	0.28	7.45	1.49	2.98
	60	0.336	8.16	1.63	3.26
	70	0.392	8.81	1.76	3.52
	80	0.448	9.42	1.88	3.77
	90	0.504	9.99	2.00	4.00
	100	0.56	10.53	2.11	4.21

1¼" PEX pipe expansion arm

PEX with PEX-a Pipe Support, strut and strut clamps has a thermal expansion rate of 0.08"/10°F ΔT/100 ft. (2.03mm/5.56°C ΔT/30.48m).

Delta T (ΔT)	Run (ft)	Delta L (in)	Flexible arm length (in)	L1 (in)	L2 (in)
80	50	0.32	7.96	1.59	3.18
	60	0.384	8.72	1.74	3.49
	70	0.448	9.42	1.88	3.77
	80	0.512	10.07	2.01	4.03
	90	0.576	10.68	2.14	4.27
	100	0.64	11.26	2.25	4.50
90	50	0.36	8.44	1.69	3.38
	60	0.432	9.25	1.85	3.70
	70	0.504	9.99	2.00	4.00
	80	0.576	10.68	2.14	4.27
	90	0.648	11.33	2.27	4.53
	100	0.72	11.94	2.39	4.78
100	50	0.4	8.90	1.78	3.56
	60	0.48	9.75	1.95	3.90
	70	0.56	10.53	2.11	4.21
	80	0.64	11.26	2.25	4.50
	90	0.72	11.94	2.39	4.78
	100	0.8	12.59	2.52	5.03
110	50	0.44	9.33	1.87	3.73
	60	0.528	10.22	2.04	4.09
	70	0.616	11.04	2.21	4.42
	80	0.704	11.81	2.36	4.72
	90	0.792	12.52	2.50	5.01
	100	0.88	13.20	2.64	5.28
120	50	0.48	9.75	1.95	3.90
	60	0.576	10.68	2.14	4.27
	70	0.672	11.53	2.31	4.61
	80	0.768	12.33	2.47	4.93
	90	0.864	13.08	2.62	5.23
	100	0.96	13.79	2.76	5.51
130	50	0.52	10.15	2.03	4.06
	60	0.624	11.12	2.22	4.45
	70	0.728	12.01	2.40	4.80
	80	0.832	12.83	2.57	5.13
	90	0.936	13.61	2.72	5.45
	100	1.04	14.35	2.87	5.74
140	50	0.56	10.53	2.11	4.21
	60	0.672	11.53	2.31	4.61
	70	0.784	12.46	2.49	4.98
	80	0.896	13.32	2.66	5.33
	90	1.008	14.13	2.83	5.65
	100	1.12	14.89	2.98	5.96

Table E-1: PEX pipe expansion arm calculations ½" to 3"

1¼" PEX pipe expansion arm

	Delta T (ΔT)	Run (ft)	Delta L (in)	Flexible arm length (in)	L1 (in)	L2 (in)
PEX with PEX-a Pipe Support, strut and strut clamps	150	50	0.6	10.90	2.18	4.36
		60	0.72	11.94	2.39	4.78
		70	0.84	12.90	2.58	5.16
		80	0.96	13.79	2.76	5.51
		90	1.08	14.62	2.92	5.85
	160	50	0.64	11.26	2.25	4.50
		60	0.768	12.33	2.47	4.93
		70	0.896	13.32	2.66	5.33
		80	1.024	14.24	2.85	5.70
		90	1.152	15.10	3.02	6.04
	100	1.28	15.92	3.18	6.37	

1½" PEX pipe expansion arm

	Delta T (ΔT)	Run (ft)	Delta L (in)	Flexible arm length (in)	L1 (in)	L2 (in)
PEX with PEX-a Pipe Support, strut and strut clamps has a thermal expansion rate of 0.08"/10°F ΔT/100 ft. (2.03mm/5.56°C ΔT/30.48m).	10	50	0.04	3.06	0.61	1.22
		60	0.048	3.35	0.67	1.34
		70	0.056	3.62	0.72	1.45
		80	0.064	3.87	0.77	1.55
		90	0.072	4.10	0.82	1.64
		100	0.08	4.33	0.87	1.73
	20	50	0.08	4.33	0.87	1.73
		60	0.096	4.74	0.95	1.90
		70	0.112	5.12	1.02	2.05
		80	0.128	5.47	1.09	2.19
		90	0.144	5.80	1.16	2.32
		100	0.16	6.12	1.22	2.45
	30	50	0.12	5.30	1.06	2.12
		60	0.144	5.80	1.16	2.32
		70	0.168	6.27	1.25	2.51
		80	0.192	6.70	1.34	2.68
		90	0.216	7.11	1.42	2.84
		100	0.24	7.49	1.50	3.00
	40	50	0.16	6.12	1.22	2.45
		60	0.192	6.70	1.34	2.68
		70	0.224	7.24	1.45	2.90
		80	0.256	7.74	1.55	3.10
		90	0.288	8.21	1.64	3.28
		100	0.32	8.65	1.73	3.46

1½" PEX pipe expansion arm

	Delta T (ΔT)	Run (ft)	Delta L (in)	Flexible arm length (in)	L1 (in)	L2 (in)
PEX with PEX-a Pipe Support, strut and strut clamps has a thermal expansion rate of 0.08"/10°F ΔT/100 ft. (2.03mm/5.56°C ΔT/30.48m).	50	50	0.2	6.84	1.37	2.74
		60	0.24	7.49	1.50	3.00
		70	0.28	8.09	1.62	3.24
		80	0.32	8.65	1.73	3.46
		90	0.36	9.18	1.84	3.67
	60	50	0.24	7.49	1.50	3.00
		60	0.288	8.21	1.64	3.28
		70	0.336	8.87	1.77	3.55
		80	0.384	9.48	1.90	3.79
		90	0.432	10.05	2.01	4.02
	70	50	0.28	8.09	1.62	3.24
		60	0.336	8.87	1.77	3.55
		70	0.392	9.58	1.92	3.83
		80	0.448	10.24	2.05	4.10
		90	0.504	10.86	2.17	4.34
	80	50	0.32	8.65	1.73	3.46
		60	0.384	9.48	1.90	3.79
		70	0.448	10.24	2.05	4.10
		80	0.512	10.95	2.19	4.38
		90	0.576	11.61	2.32	4.64
	90	50	0.36	9.18	1.84	3.67
		60	0.432	10.05	2.01	4.02
		70	0.504	10.86	2.17	4.34
		80	0.576	11.61	2.32	4.64
		90	0.648	12.31	2.46	4.93
	100	50	0.4	9.67	1.93	3.87
		60	0.48	10.60	2.12	4.24
		70	0.56	11.45	2.29	4.58
		80	0.64	12.24	2.45	4.90
		90	0.72	12.98	2.60	5.19
	110	50	0.44	10.15	2.03	4.06
		60	0.528	11.12	2.22	4.45
		70	0.616	12.01	2.40	4.80
		80	0.704	12.83	2.57	5.13
		90	0.792	13.61	2.72	5.45
	100	0.88	14.35	2.87	5.74	

Table E-1: PEX pipe expansion arm calculations ½" to 3"

1½" PEX pipe expansion arm

PEX with PEX-a Pipe Support, strut and strut clamps has a thermal expansion rate of 0.08"/10°F ΔT/100 ft. (2.03mm/5.56°C ΔT/30.48m).

Delta T (ΔT)	Run (ft)	Delta L (in)	Flexible arm length (in)	L1 (in)	L2 (in)
120	50	0.48	10.60	2.12	4.24
	60	0.576	11.61	2.32	4.64
	70	0.672	12.54	2.51	5.02
	80	0.768	13.41	2.68	5.36
	90	0.864	14.22	2.84	5.69
	100	0.96	14.99	3.00	6.00
130	50	0.52	11.03	2.21	4.41
	60	0.624	12.08	2.42	4.83
	70	0.728	13.05	2.61	5.22
	80	0.832	13.95	2.79	5.58
	90	0.936	14.80	2.96	5.92
	100	1.04	15.60	3.12	6.24
140	50	0.56	11.45	2.29	4.58
	60	0.672	12.54	2.51	5.02
	70	0.784	13.54	2.71	5.42
	80	0.896	14.48	2.90	5.79
	90	1.008	15.36	3.07	6.14
	100	1.12	16.19	3.24	6.48
150	50	0.6	11.85	2.37	4.74
	60	0.72	12.98	2.60	5.19
	70	0.84	14.02	2.80	5.61
	80	0.96	14.99	3.00	6.00
	90	1.08	15.90	3.18	6.36
	100	1.2	16.76	3.35	6.70
160	50	0.64	12.24	2.45	4.90
	60	0.768	13.41	2.68	5.36
	70	0.896	14.48	2.90	5.79
	80	1.024	15.48	3.10	6.19
	90	1.152	16.42	3.28	6.57
	100	1.28	17.31	3.46	6.92

2" PEX pipe expansion arm

PEX with PEX-a Pipe Support, strut and strut clamps has a thermal expansion rate of 0.08"/10°F ΔT/100 ft. (2.03mm/5.56°C ΔT/30.48m).

Delta T (ΔT)	Run (ft)	Delta L (in)	Flexible arm length (in)	L1 (in)	L2 (in)
20	50	0.08	4.95	0.99	1.98
	60	0.096	5.42	1.08	2.17
	70	0.112	5.85	1.17	2.34
	80	0.128	6.26	1.25	2.50
	90	0.144	6.64	1.33	2.66
	100	0.16	7.00	1.40	2.80
30	50	0.12	6.06	1.21	2.42
	60	0.144	6.64	1.33	2.66
	70	0.168	7.17	1.43	2.87
	80	0.192	7.66	1.53	3.07
	90	0.216	8.13	1.63	3.25
	100	0.24	8.57	1.71	3.43
40	50	0.16	7.00	1.40	2.80
	60	0.192	7.66	1.53	3.07
	70	0.224	8.28	1.66	3.31
	80	0.256	8.85	1.77	3.54
	90	0.288	9.39	1.88	3.76
	100	0.32	9.90	1.98	3.96
50	50	0.2	7.82	1.56	3.13
	60	0.24	8.57	1.71	3.43
	70	0.28	9.26	1.85	3.70
	80	0.32	9.90	1.98	3.96
	90	0.36	10.50	2.10	4.20
	100	0.4	11.06	2.21	4.43
60	50	0.24	8.57	1.71	3.43
	60	0.288	9.39	1.88	3.76
	70	0.336	10.14	2.03	4.06
	80	0.384	10.84	2.17	4.34
	90	0.432	11.50	2.30	4.60
	100	0.48	12.12	2.42	4.85
70	50	0.28	9.26	1.85	3.70
	60	0.336	10.14	2.03	4.06
	70	0.392	10.95	2.19	4.38
	80	0.448	11.71	2.34	4.68
	90	0.504	12.42	2.48	4.97
	100	0.56	13.09	2.62	5.24
80	50	0.32	9.90	1.98	3.96
	60	0.384	10.84	2.17	4.34
	70	0.448	11.71	2.34	4.68
	80	0.512	12.52	2.50	5.01
	90	0.576	13.28	2.66	5.31
	100	0.64	13.99	2.80	5.60

2" PEX pipe expansion arm

PEX with PEX-a Pipe Support, strut and strut clamps has a thermal expansion rate of 0.08"/10°F ΔT/100 ft. (2.03mm/5.56°C ΔT/30.48m).

Delta T (ΔT)	Run (ft)	Delta L (in)	Flexible arm length (in)	L1 (in)	L2 (in)
10	50	0.04	3.50	0.70	1.40
	60	0.048	3.83	0.77	1.53
	70	0.056	4.14	0.83	1.66
	80	0.064	4.43	0.89	1.77
	90	0.072	4.69	0.94	1.88
	100	0.08	4.95	0.99	1.98

Table E-1: PEX pipe expansion arm calculations ½" to 3"

2" PEX pipe expansion arm

PEX with PEX-a Pipe Support, strut and strut clamps has a thermal expansion rate of 0.08"/10°F ΔT/100 ft. (2.03mm/5.56°C ΔT/30.48m).

Delta T (ΔT)	Run (ft)	Delta L (in)	Flexible arm length (in)	L1 (in)	L2 (in)
90	50	0.36	10.50	2.10	4.20
	60	0.432	11.50	2.30	4.60
	70	0.504	12.42	2.48	4.97
	80	0.576	13.28	2.66	5.31
	90	0.648	14.08	2.82	5.63
	100	0.72	14.84	2.97	5.94
100	50	0.4	11.06	2.21	4.43
	60	0.48	12.12	2.42	4.85
	70	0.56	13.09	2.62	5.24
	80	0.64	13.99	2.80	5.60
	90	0.72	14.84	2.97	5.94
	100	0.8	15.65	3.13	6.26
110	50	0.44	11.60	2.32	4.64
	60	0.528	12.71	2.54	5.08
	70	0.616	13.73	2.75	5.49
	80	0.704	14.68	2.94	5.87
	90	0.792	15.57	3.11	6.23
	100	0.88	16.41	3.28	6.56
120	50	0.48	12.12	2.42	4.85
	60	0.576	13.28	2.66	5.31
	70	0.672	14.34	2.87	5.74
	80	0.768	15.33	3.07	6.13
	90	0.864	16.26	3.25	6.50
	100	0.96	17.14	3.43	6.86
130	50	0.52	12.61	2.52	5.05
	60	0.624	13.82	2.76	5.53
	70	0.728	14.93	2.99	5.97
	80	0.832	15.96	3.19	6.38
	90	0.936	16.92	3.38	6.77
	100	1.04	17.84	3.57	7.14
140	50	0.56	13.09	2.62	5.24
	60	0.672	14.34	2.87	5.74
	70	0.784	15.49	3.10	6.20
	80	0.896	16.56	3.31	6.62
	90	1.008	17.56	3.51	7.03
	100	1.12	18.51	3.70	7.41
150	50	0.6	13.55	2.71	5.42
	60	0.72	14.84	2.97	5.94
	70	0.84	16.03	3.21	6.41
	80	0.96	17.14	3.43	6.86
	90	1.08	18.18	3.64	7.27
	100	1.2	19.16	3.83	7.66

2" PEX pipe expansion arm

PEX with PEX-a Pipe Support, strut and strut clamps has a thermal expansion rate of 0.08"/10°F ΔT/100 ft. (2.03mm/5.56°C ΔT/30.48m).

Delta T (ΔT)	Run (ft)	Delta L (in)	Flexible arm length (in)	L1 (in)	L2 (in)
160	50	0.64	13.99	2.80	5.60
	60	0.768	15.33	3.07	6.13
	70	0.896	16.56	3.31	6.62
	80	1.024	17.70	3.54	7.08
	90	1.152	18.78	3.76	7.51
	100	1.28	19.79	3.96	7.92

2½" PEX pipe expansion arm

PEX with PEX-a Pipe Support, strut and strut clamps has a thermal expansion rate of 0.08"/10°F ΔT/100 ft. (2.03mm/5.56°C ΔT/30.48m).

Delta T (ΔT)	Run (ft)	Delta L (in)	Flexible arm length (in)	L1 (in)	L2 (in)
10	50	0.04	3.89	0.78	1.56
	60	0.048	4.26	0.85	1.70
	70	0.056	4.60	0.92	1.84
	80	0.064	4.92	0.98	1.97
	90	0.072	5.22	1.04	2.09
	100	0.08	5.50	1.10	2.20
20	50	0.08	5.50	1.10	2.20
	60	0.096	6.02	1.20	2.41
	70	0.112	6.51	1.30	2.60
	80	0.128	6.96	1.39	2.78
	90	0.144	7.38	1.48	2.95
	100	0.16	7.78	1.56	3.11
30	50	0.12	6.73	1.35	2.69
	60	0.144	7.38	1.48	2.95
	70	0.168	7.97	1.59	3.19
	80	0.192	8.52	1.70	3.41
	90	0.216	9.04	1.81	3.61
	100	0.24	9.52	1.90	3.81
40	50	0.16	7.78	1.56	3.11
	60	0.192	8.52	1.70	3.41
	70	0.224	9.20	1.84	3.68
	80	0.256	9.84	1.97	3.93
	90	0.288	10.43	2.09	4.17
	100	0.32	11.00	2.20	4.40
50	50	0.2	8.69	1.74	3.48
	60	0.24	9.52	1.90	3.81
	70	0.28	10.29	2.06	4.12
	80	0.32	11.00	2.20	4.40
	90	0.36	11.67	2.33	4.67
	100	0.4	12.30	2.46	4.92

Table E-1: PEX pipe expansion arm calculations ½" to 3"

2½" PEX pipe expansion arm

Delta T (ΔT)	Run (ft)	Delta L (in)	Flexible arm length (in)	L1 (in)	L2 (in)
60	50	0.24	9.52	1.90	3.81
	60	0.288	10.43	2.09	4.17
	70	0.336	11.27	2.25	4.51
	80	0.384	12.05	2.41	4.82
	90	0.432	12.78	2.56	5.11
70	100	0.48	13.47	2.69	5.39
	50	0.28	10.29	2.06	4.12
	60	0.336	11.27	2.25	4.51
	70	0.392	12.17	2.43	4.87
	80	0.448	13.01	2.60	5.21
80	90	0.504	13.80	2.76	5.52
	100	0.56	14.55	2.91	5.82
	50	0.32	11.00	2.20	4.40
	60	0.384	12.05	2.41	4.82
	70	0.448	13.01	2.60	5.21
90	80	0.512	13.91	2.78	5.56
	90	0.576	14.76	2.95	5.90
	100	0.64	15.55	3.11	6.22
	50	0.36	11.67	2.33	4.67
	60	0.432	12.78	2.56	5.11
100	70	0.504	13.80	2.76	5.52
	80	0.576	14.76	2.95	5.90
	90	0.648	15.65	3.13	6.26
	100	0.72	16.50	3.30	6.60
	50	0.4	12.30	2.46	4.92
110	60	0.48	13.47	2.69	5.39
	70	0.56	14.55	2.91	5.82
	80	0.64	15.55	3.11	6.22
	90	0.72	16.50	3.30	6.60
	100	0.8	17.39	3.48	6.96
120	50	0.44	12.90	2.58	5.16
	60	0.528	14.13	2.83	5.65
	70	0.616	15.26	3.05	6.10
	80	0.704	16.31	3.26	6.53
	90	0.792	17.30	3.46	6.92
130	100	0.88	18.24	3.65	7.30
	50	0.48	13.47	2.69	5.39
	60	0.576	14.76	2.95	5.90
	70	0.672	15.94	3.19	6.38
	80	0.768	17.04	3.41	6.82
140	90	0.864	18.07	3.61	7.23
	100	0.96	19.05	3.81	7.62

PEX with PEX-a Pipe Support, strut and strut clamps has a thermal expansion rate of 0.08"/10°F ΔT/100 ft. (2.03mm/5.56°C ΔT/30.48m).

2½" PEX pipe expansion arm

Delta T (ΔT)	Run (ft)	Delta L (in)	Flexible arm length (in)	L1 (in)	L2 (in)
130	50	0.52	14.02	2.80	5.61
	60	0.624	15.36	3.07	6.14
	70	0.728	16.59	3.32	6.64
	80	0.832	17.73	3.55	7.09
	90	0.936	18.81	3.76	7.52
140	100	1.04	19.83	3.97	7.93
	50	0.56	14.55	2.91	5.82
	60	0.672	15.94	3.19	6.38
	70	0.784	17.21	3.44	6.89
	80	0.896	18.40	3.68	7.36
150	90	1.008	19.52	3.90	7.81
	100	1.12	20.58	4.12	8.23
	50	0.6	15.06	3.01	6.02
	60	0.72	16.50	3.30	6.60
	70	0.84	17.82	3.56	7.13
160	80	0.96	19.05	3.81	7.62
	90	1.08	20.20	4.04	8.08
	100	1.2	21.30	4.26	8.52
	50	0.64	15.55	3.11	6.22
	60	0.768	17.04	3.41	6.82
170	70	0.896	18.40	3.68	7.36
	80	1.024	19.67	3.93	7.87
	90	1.152	20.87	4.17	8.35
	100	1.28	22.00	4.40	8.80

PEX with PEX-a Pipe Support, strut and strut clamps has a thermal expansion rate of 0.08"/10°F ΔT/100 ft. (2.03mm/5.56°C ΔT/30.48m).

3" PEX pipe expansion arm

Delta T (ΔT)	Run (ft)	Delta L (in)	Flexible arm length (in)	L1 (in)	L2 (in)
10	50	0.04	4.24	0.85	1.70
	60	0.048	4.65	0.93	1.86
	70	0.056	5.02	1.00	2.01
	80	0.064	5.37	1.07	2.15
	90	0.072	5.69	1.14	2.28
20	100	0.08	6.00	1.20	2.40
	50	0.08	6.00	1.20	2.40
	60	0.096	6.57	1.31	2.63
	70	0.112	7.10	1.42	2.84
	80	0.128	7.59	1.52	3.04
30	90	0.144	8.05	1.61	3.22
	100	0.16	8.49	1.70	3.39

PEX with PEX-a Pipe Support, strut and strut clamps

Table E-1: PEX pipe expansion arm calculations ½" to 3"

3" PEX pipe expansion arm

PEX with PEX-a Pipe Support, strut and strut clamps has a thermal expansion rate of 0.08"/10°F ΔT/100 ft. (2.03mm/5.56°C ΔT/30.48m).

Delta T (ΔT)	Run (ft)	Delta L (in)	Flexible arm length (in)	L1 (in)	L2 (in)
30	50	0.12	7.35	1.47	2.94
	60	0.144	8.05	1.61	3.22
	70	0.168	8.69	1.74	3.48
	80	0.192	9.30	1.86	3.72
	90	0.216	9.86	1.97	3.94
	100	0.24	10.39	2.08	4.16
40	50	0.16	8.49	1.70	3.39
	60	0.192	9.30	1.86	3.72
	70	0.224	10.04	2.01	4.02
	80	0.256	10.73	2.15	4.29
	90	0.288	11.38	2.28	4.55
	100	0.32	12.00	2.40	4.80
50	50	0.2	9.49	1.90	3.79
	60	0.24	10.39	2.08	4.16
	70	0.28	11.22	2.24	4.49
	80	0.32	12.00	2.40	4.80
	90	0.36	12.73	2.55	5.09
	100	0.4	13.42	2.68	5.37
60	50	0.24	10.39	2.08	4.16
	60	0.288	11.38	2.28	4.55
	70	0.336	12.30	2.46	4.92
	80	0.384	13.15	2.63	5.26
	90	0.432	13.94	2.79	5.58
	100	0.48	14.70	2.94	5.88
70	50	0.28	11.22	2.24	4.49
	60	0.336	12.30	2.46	4.92
	70	0.392	13.28	2.66	5.31
	80	0.448	14.20	2.84	5.68
	90	0.504	15.06	3.01	6.02
	100	0.56	15.87	3.17	6.35
80	50	0.32	12.00	2.40	4.80
	60	0.384	13.15	2.63	5.26
	70	0.448	14.20	2.84	5.68
	80	0.512	15.18	3.04	6.07
	90	0.576	16.10	3.22	6.44
	100	0.64	16.97	3.39	6.79
90	50	0.36	12.73	2.55	5.09
	60	0.432	13.94	2.79	5.58
	70	0.504	15.06	3.01	6.02
	80	0.576	16.10	3.22	6.44
	90	0.648	17.08	3.42	6.83
	100	0.72	18.00	3.60	7.20

3" PEX pipe expansion arm

PEX with PEX-a Pipe Support, strut and strut clamps has a thermal expansion rate of 0.08"/10°F ΔT/100 ft. (2.03mm/5.56°C ΔT/30.48m).

Delta T (ΔT)	Run (ft)	Delta L (in)	Flexible arm length (in)	L1 (in)	L2 (in)
100	50	0.4	13.42	2.68	5.37
	60	0.48	14.70	2.94	5.88
	70	0.56	15.87	3.17	6.35
	80	0.64	16.97	3.39	6.79
	90	0.72	18.00	3.60	7.20
	100	0.8	18.97	3.79	7.59
110	50	0.44	14.07	2.81	5.63
	60	0.528	15.41	3.08	6.17
	70	0.616	16.65	3.33	6.66
	80	0.704	17.80	3.56	7.12
	90	0.792	18.88	3.78	7.55
	100	0.88	19.90	3.98	7.96
120	50	0.48	14.70	2.94	5.88
	60	0.576	16.10	3.22	6.44
	70	0.672	17.39	3.48	6.96
	80	0.768	18.59	3.72	7.44
	90	0.864	19.72	3.94	7.89
	100	0.96	20.78	4.16	8.31
130	50	0.52	15.30	3.06	6.12
	60	0.624	16.76	3.35	6.70
	70	0.728	18.10	3.62	7.24
	80	0.832	19.35	3.87	7.74
	90	0.936	20.52	4.10	8.21
	100	1.04	21.63	4.33	8.65
140	50	0.56	15.87	3.17	6.35
	60	0.672	17.39	3.48	6.96
	70	0.784	18.78	3.76	7.51
	80	0.896	20.08	4.02	8.03
	90	1.008	21.30	4.26	8.52
	100	1.12	22.45	4.49	8.98
150	50	0.6	16.43	3.29	6.57
	60	0.72	18.00	3.60	7.20
	70	0.84	19.44	3.89	7.78
	80	0.96	20.78	4.16	8.31
	90	1.08	22.05	4.41	8.82
	100	1.2	23.24	4.65	9.30
160	50	0.64	16.97	3.39	6.79
	60	0.768	18.59	3.72	7.44
	70	0.896	20.08	4.02	8.03
	80	1.024	21.47	4.29	8.59
	90	1.152	22.77	4.55	9.11
	100	1.28	24.00	4.80	9.60

Table E-1: PEX Pipe expansion arm calculations ½" to 3"

PEX with PEX-a Pipe Support and clevis hangers or loops

has a thermal expansion rate of 0.12/10°F ΔT/100 ft. (3.05mm/5.56°C ΔT/30.48m)

½" PEX pipe expansion arm

PEX with PEX-a Pipe Support and clevis hangers or loops has a thermal expansion rate of 0.12/10°F ΔT/100 ft. (3.05mm/5.56°C ΔT/30.48m).

Delta T (ΔT)	Run (ft)	Delta L (in)	Flexible arm length (in)	L1 (in)	L2 (in)
10	50	0.06	2.32	0.46	0.93
	60	0.072	2.55	0.51	1.02
	70	0.084	2.75	0.55	1.10
	80	0.096	2.94	0.59	1.18
	90	0.108	3.12	0.62	1.25
	100	0.12	3.29	0.66	1.31
20	50	0.12	3.29	0.66	1.31
	60	0.144	3.60	0.72	1.44
	70	0.168	3.89	0.78	1.56
	80	0.192	4.16	0.83	1.66
	90	0.216	4.41	0.88	1.76
	100	0.24	4.65	0.93	1.86
30	50	0.18	4.02	0.80	1.61
	60	0.216	4.41	0.88	1.76
	70	0.252	4.76	0.95	1.90
	80	0.288	5.09	1.02	2.04
	90	0.324	5.40	1.08	2.16
	100	0.36	5.69	1.14	2.28
40	50	0.24	4.65	0.93	1.86
	60	0.288	5.09	1.02	2.04
	70	0.336	5.50	1.10	2.20
	80	0.384	5.88	1.18	2.35
	90	0.432	6.24	1.25	2.49
	100	0.48	6.57	1.31	2.63
50	50	0.3	5.20	1.04	2.08
	60	0.36	5.69	1.14	2.28
	70	0.42	6.15	1.23	2.46
	80	0.48	6.57	1.31	2.63
	90	0.54	6.97	1.39	2.79
	100	0.6	7.35	1.47	2.94
60	50	0.36	5.69	1.14	2.28
	60	0.432	6.24	1.25	2.49
	70	0.504	6.73	1.35	2.69
	80	0.576	7.20	1.44	2.88
	90	0.648	7.64	1.53	3.05
	100	0.72	8.05	1.61	3.22

½" PEX pipe expansion arm

PEX with PEX-a Pipe Support and clevis hangers or loops has a thermal expansion rate of 0.12/10°F ΔT/100 ft. (3.05mm/5.56°C ΔT/30.48m).

Delta T (ΔT)	Run (ft)	Delta L (in)	Flexible arm length (in)	L1 (in)	L2 (in)
70	50	0.42	6.15	1.23	2.46
	60	0.504	6.73	1.35	2.69
	70	0.588	7.27	1.45	2.91
	80	0.672	7.78	1.56	3.11
	90	0.756	8.25	1.65	3.30
	100	0.84	8.69	1.74	3.48
80	50	0.48	6.57	1.31	2.63
	60	0.576	7.20	1.44	2.88
	70	0.672	7.78	1.56	3.11
	80	0.768	8.31	1.66	3.33
	90	0.864	8.82	1.76	3.53
	100	0.96	9.30	1.86	3.72
90	50	0.54	6.97	1.39	2.79
	60	0.648	7.64	1.53	3.05
	70	0.756	8.25	1.65	3.30
	80	0.864	8.82	1.76	3.53
	90	0.972	9.35	1.87	3.74
	100	1.08	9.86	1.97	3.94
100	50	0.6	7.35	1.47	2.94
	60	0.72	8.05	1.61	3.22
	70	0.84	8.69	1.74	3.48
	80	0.96	9.30	1.86	3.72
	90	1.08	9.86	1.97	3.94
	100	1.2	10.39	2.08	4.16
110	50	0.66	7.71	1.54	3.08
	60	0.792	8.44	1.69	3.38
	70	0.924	9.12	1.82	3.65
	80	1.056	9.75	1.95	3.90
	90	1.188	10.34	2.07	4.14
	100	1.32	10.90	2.18	4.36
120	50	0.72	8.05	1.61	3.22
	60	0.864	8.82	1.76	3.53
	70	1.008	9.52	1.90	3.81
	80	1.152	10.18	2.04	4.07
	90	1.296	10.80	2.16	4.32
	100	1.44	11.38	2.28	4.55

Table E-2: PEX pipe expansion arm calculations ½" to 3"

½" PEX pipe expansion arm

Delta T (ΔT)	Run (ft)	Delta L (in)	Flexible arm length (in)	L1 (in)	L2 (in)
130	50	0.78	8.38	1.68	3.35
	60	0.936	9.18	1.84	3.67
	70	1.092	9.91	1.98	3.97
	80	1.248	10.60	2.12	4.24
	90	1.404	11.24	2.25	4.50
	100	1.56	11.85	2.37	4.74
140	50	0.84	8.69	1.74	3.48
	60	1.008	9.52	1.90	3.81
	70	1.176	10.29	2.06	4.12
	80	1.344	11.00	2.20	4.40
	90	1.512	11.67	2.33	4.67
	100	1.68	12.30	2.46	4.92
150	50	0.9	9.00	1.80	3.60
	60	1.08	9.86	1.97	3.94
	70	1.26	10.65	2.13	4.26
	80	1.44	11.38	2.28	4.55
	90	1.62	12.07	2.41	4.83
	100	1.8	12.73	2.55	5.09
160	50	0.96	9.30	1.86	3.72
	60	1.152	10.18	2.04	4.07
	70	1.344	11.00	2.20	4.40
	80	1.536	11.76	2.35	4.70
	90	1.728	12.47	2.49	4.99
	100	1.92	13.15	2.63	5.26

PEX with PEX-a Pipe Support and clevis hangers or loops has a thermal expansion rate of 0.12/10°F ΔT/100 ft. (3.05mm/5.56°C ΔT/30.48m).

¾" PEX pipe expansion arm

Delta T (ΔT)	Run (ft)	Delta L (in)	Flexible Arm Length (in)	L1 (in)	L2 (in)
30	50	0.18	4.76	0.95	1.90
	60	0.216	5.22	1.04	2.09
	70	0.252	5.63	1.13	2.25
	80	0.288	6.02	1.20	2.41
	90	0.324	6.39	1.28	2.56
	100	0.36	6.73	1.35	2.69
40	50	0.24	5.50	1.10	2.20
	60	0.288	6.02	1.20	2.41
	70	0.336	6.51	1.30	2.60
	80	0.384	6.96	1.39	2.78
	90	0.432	7.38	1.48	2.95
	100	0.48	7.78	1.56	3.11
50	50	0.3	6.15	1.23	2.46
	60	0.36	6.73	1.35	2.69
	70	0.42	7.27	1.45	2.91
	80	0.48	7.78	1.56	3.11
	90	0.54	8.25	1.65	3.30
	100	0.6	8.69	1.74	3.48
60	50	0.36	6.73	1.35	2.69
	60	0.432	7.38	1.48	2.95
	70	0.504	7.97	1.59	3.19
	80	0.576	8.52	1.70	3.41
	90	0.648	9.04	1.81	3.61
	100	0.72	9.52	1.90	3.81
70	50	0.42	7.27	1.45	2.91
	60	0.504	7.97	1.59	3.19
	70	0.588	8.61	1.72	3.44
	80	0.672	9.20	1.84	3.68
	90	0.756	9.76	1.95	3.90
	100	0.84	10.29	2.06	4.12
80	50	0.48	7.78	1.56	3.11
	60	0.576	8.52	1.70	3.41
	70	0.672	9.20	1.84	3.68
	80	0.768	9.84	1.97	3.93
	90	0.864	10.43	2.09	4.17
	100	0.96	11.00	2.20	4.40
90	50	0.54	8.25	1.65	3.30
	60	0.648	9.04	1.81	3.61
	70	0.756	9.76	1.95	3.90
	80	0.864	10.43	2.09	4.17
	90	0.972	11.07	2.21	4.43
	100	1.08	11.67	2.33	4.67

PEX with PEX-a Pipe Support and clevis hangers or loops has a thermal expansion rate of 0.12/10°F ΔT/100 ft. (3.05mm/5.56°C ΔT/30.48m).

¾" PEX pipe expansion arm

Delta T (ΔT)	Run (ft)	Delta L (in)	Flexible Arm Length (in)	L1 (in)	L2 (in)
10	50	0.06	2.75	0.55	1.10
	60	0.072	3.01	0.60	1.20
	70	0.084	3.25	0.65	1.30
	80	0.096	3.48	0.70	1.39
	90	0.108	3.69	0.74	1.48
	100	0.12	3.89	0.78	1.56
20	50	0.12	3.89	0.78	1.56
	60	0.144	4.26	0.85	1.70
	70	0.168	4.60	0.92	1.84
	80	0.192	4.92	0.98	1.97
	90	0.216	5.22	1.04	2.09
	100	0.24	5.50	1.10	2.20

PEX with PEX-a Pipe Support and clevis hangers or loops

Table E-2: PEX pipe expansion arm calculations ½" to 3"

¾" PEX pipe expansion arm

PEX with PEX-a Pipe Support and clevis hangers or loops has a thermal expansion rate of 0.12/10°F ΔT/100 ft. (3.05mm/5.56°C ΔT/30.48m).

Delta T (ΔT)	Run (ft)	Delta L (in)	Flexible Arm Length (in)	L1 (in)	L2 (in)
100	50	0.6	8.69	1.74	3.48
	60	0.72	9.52	1.90	3.81
	70	0.84	10.29	2.06	4.12
	80	0.96	11.00	2.20	4.40
	90	1.08	11.67	2.33	4.67
110	100	1.2	12.30	2.46	4.92
	50	0.66	9.12	1.82	3.65
	60	0.792	9.99	2.00	4.00
	70	0.924	10.79	2.16	4.32
	80	1.056	11.53	2.31	4.61
120	90	1.188	12.23	2.45	4.89
	100	1.32	12.90	2.58	5.16
	50	0.72	9.52	1.90	3.81
	60	0.864	10.43	2.09	4.17
	70	1.008	11.27	2.25	4.51
130	80	1.152	12.05	2.41	4.82
	90	1.296	12.78	2.56	5.11
	100	1.44	13.47	2.69	5.39
	50	0.78	9.91	1.98	3.97
	60	0.936	10.86	2.17	4.34
140	70	1.092	11.73	2.35	4.69
	80	1.248	12.54	2.51	5.02
	90	1.404	13.30	2.66	5.32
	100	1.56	14.02	2.80	5.61
	50	0.84	10.29	2.06	4.12
150	60	1.008	11.27	2.25	4.51
	70	1.176	12.17	2.43	4.87
	80	1.344	13.01	2.60	5.21
	90	1.512	13.80	2.76	5.52
	100	1.68	14.55	2.91	5.82
160	50	0.9	10.65	2.13	4.26
	60	1.08	11.67	2.33	4.67
	70	1.26	12.60	2.52	5.04
	80	1.44	13.47	2.69	5.39
	90	1.62	14.29	2.86	5.71
170	100	1.8	15.06	3.01	6.02
	50	0.96	11.00	2.20	4.40
	60	1.152	12.05	2.41	4.82
	70	1.344	13.01	2.60	5.21
	80	1.536	13.91	2.78	5.56
180	90	1.728	14.76	2.95	5.90
	100	1.92	15.55	3.11	6.22

1" PEX pipe expansion arm

PEX with PEX-a Pipe Support and clevis hangers or loops has a thermal expansion rate of 0.12/10°F ΔT/100 ft. (3.05mm/5.56°C ΔT/30.48m).

Delta T (ΔT)	Run (ft)	Delta L (in)	Flexible arm length (in)	L1 (in)	L2 (in)
10	50	0.06	3.12	0.62	1.25
	60	0.072	3.42	0.68	1.37
	70	0.084	3.69	0.74	1.48
	80	0.096	3.94	0.79	1.58
	90	0.108	4.18	0.84	1.67
20	100	0.12	4.41	0.88	1.76
	50	0.12	4.41	0.88	1.76
	60	0.144	4.83	0.97	1.93
	70	0.168	5.22	1.04	2.09
	80	0.192	5.58	1.12	2.23
30	90	0.216	5.92	1.18	2.37
	100	0.24	6.24	1.25	2.49
	50	0.18	5.40	1.08	2.16
	60	0.216	5.92	1.18	2.37
	70	0.252	6.39	1.28	2.56
40	80	0.288	6.83	1.37	2.73
	90	0.324	7.24	1.45	2.90
	100	0.36	7.64	1.53	3.05
	50	0.24	6.24	1.25	2.49
	60	0.072	3.42	0.68	1.37
50	70	0.084	3.69	0.74	1.48
	80	0.096	3.94	0.79	1.58
	90	0.108	4.18	0.84	1.67
	100	0.12	4.41	0.88	1.76
	50	0.3	6.97	1.39	2.79
60	60	0.36	7.64	1.53	3.05
	70	0.42	8.25	1.65	3.30
	80	0.48	8.82	1.76	3.53
	90	0.54	9.35	1.87	3.74
	100	0.6	9.86	1.97	3.94
70	50	0.36	7.64	1.53	3.05
	60	0.432	8.37	1.67	3.35
	70	0.504	9.04	1.81	3.61
	80	0.576	9.66	1.93	3.86
	90	0.648	10.25	2.05	4.10
80	100	0.72	10.80	2.16	4.32
	50	0.42	8.25	1.65	3.30
	60	0.504	9.04	1.81	3.61
	70	0.588	9.76	1.95	3.90
	80	0.672	10.43	2.09	4.17
90	90	0.756	11.07	2.21	4.43
	100	0.84	11.67	2.33	4.67

Table E-2: PEX pipe expansion arm calculations ½" to 3"

1" PEX pipe expansion arm

PEX with PEX-a Pipe Support and clevis hangers or loops has a thermal expansion rate of 0.12/10°F ΔT/100 ft. (3.05mm/5.56°C ΔT/30.48m).

Delta T (ΔT)	Run (ft)	Delta L (in)	Flexible arm length (in)	L1 (in)	L2 (in)
80	50	0.48	8.82	1.76	3.53
	60	0.576	9.66	1.93	3.86
	70	0.672	10.43	2.09	4.17
	80	0.768	11.15	2.23	4.46
	90	0.864	11.83	2.37	4.73
	100	0.96	12.47	2.49	4.99
90	50	0.06	3.12	0.62	1.25
	60	0.072	3.42	0.68	1.37
	70	0.084	3.69	0.74	1.48
	80	0.096	3.94	0.79	1.58
	90	0.108	4.18	0.84	1.67
	100	0.12	4.41	0.88	1.76
100	50	0.12	4.41	0.88	1.76
	60	0.144	4.83	0.97	1.93
	70	0.168	5.22	1.04	2.09
	80	0.192	5.58	1.12	2.23
	90	0.216	5.92	1.18	2.37
	100	0.24	6.24	1.25	2.49
110	50	0.66	10.34	2.07	4.14
	60	0.792	11.33	2.27	4.53
	70	0.924	12.23	2.45	4.89
	80	1.056	13.08	2.62	5.23
	90	1.188	13.87	2.77	5.55
	100	1.32	14.62	2.92	5.85
120	50	0.72	10.80	2.16	4.32
	60	0.864	11.83	2.37	4.73
	70	1.008	12.78	2.56	5.11
	80	1.152	13.66	2.73	5.46
	90	1.296	14.49	2.90	5.80
	100	1.44	15.27	3.05	6.11
130	50	0.78	11.24	2.25	4.50
	60	0.936	12.31	2.46	4.93
	70	1.092	13.30	2.66	5.32
	80	1.248	14.22	2.84	5.69
	90	1.404	15.08	3.02	6.03
	100	1.56	15.90	3.18	6.36
140	50	0.84	11.67	2.33	4.67
	60	1.008	12.78	2.56	5.11
	70	1.176	13.80	2.76	5.52
	80	1.344	14.76	2.95	5.90
	90	1.512	15.65	3.13	6.26
	100	1.68	16.50	3.30	6.60

1" PEX pipe expansion arm

PEX with PEX-a Pipe Support and Clevis Hangers or Loops

Delta T (ΔT)	Run (ft)	Delta L (in)	Flexible arm length (in)	L1 (in)	L2 (in)
150	50	0.9	12.07	2.41	4.83
	60	1.08	13.23	2.65	5.29
	70	1.26	14.29	2.86	5.71
	80	1.44	15.27	3.05	6.11
	90	1.62	16.20	3.24	6.48
	100	1.8	17.08	3.42	6.83
160	50	0.96	12.47	2.49	4.99
	60	1.152	13.66	2.73	5.46
	70	1.344	14.76	2.95	5.90
	80	1.536	15.77	3.15	6.31
	90	1.728	16.73	3.35	6.69
	100	1.92	17.64	3.53	7.05

1¼" PEX pipe expansion arm

PEX with PEX-a Pipe Support and clevis hangers or loops has a thermal expansion rate of 0.12/10°F ΔT/100 ft. (3.05mm/5.56°C ΔT/30.48m).

Delta T (ΔT)	Run (ft)	Delta L (in)	Flexible arm length (in)	L1 (in)	L2 (in)
10	50	0.06	3.45	0.69	1.38
	60	0.072	3.78	0.76	1.51
	70	0.084	4.08	0.82	1.63
	80	0.096	4.36	0.87	1.74
	90	0.108	4.62	0.92	1.85
	100	0.12	4.87	0.97	1.95
20	50	0.12	4.87	0.97	1.95
	60	0.144	5.34	1.07	2.14
	70	0.168	5.77	1.15	2.31
	80	0.192	6.17	1.23	2.47
	90	0.216	6.54	1.31	2.62
	100	0.24	6.89	1.38	2.76
30	50	0.18	5.97	1.19	2.39
	60	0.216	6.54	1.31	2.62
	70	0.252	7.06	1.41	2.83
	80	0.288	7.55	1.51	3.02
	90	0.324	8.01	1.60	3.20
	100	0.36	8.44	1.69	3.38
40	50	0.24	6.89	1.38	2.76
	60	0.288	7.55	1.51	3.02
	70	0.336	8.16	1.63	3.26
	80	0.384	8.72	1.74	3.49
	90	0.432	9.25	1.85	3.70
	100	0.48	9.75	1.95	3.90

Table E-2: PEX Pipe expansion arm calculations ½" to 3"

1¼" PEX pipe expansion arm

PEX with PEX-a Pipe Support and clevis hangers or loops has a thermal expansion rate of 0.12/10°F ΔT/100 ft. (3.05mm/5.56°C ΔT/30.48m).

Delta T (ΔT)	Run (ft)	Delta L (in)	Flexible arm length (in)	L1 (in)	L2 (in)
50	50	0.3	7.71	1.54	3.08
	60	0.36	8.44	1.69	3.38
	70	0.42	9.12	1.82	3.65
	80	0.48	9.75	1.95	3.90
	90	0.54	10.34	2.07	4.14
	100	0.6	10.90	2.18	4.36
60	50	0.36	8.44	1.69	3.38
	60	0.432	9.25	1.85	3.70
	70	0.504	9.99	2.00	4.00
	80	0.576	10.68	2.14	4.27
	90	0.648	11.33	2.27	4.53
	100	0.72	11.94	2.39	4.78
70	50	0.42	9.12	1.82	3.65
	60	0.504	9.99	2.00	4.00
	70	0.588	10.79	2.16	4.32
	80	0.672	11.53	2.31	4.61
	90	0.756	12.23	2.45	4.89
	100	0.84	12.90	2.58	5.16
80	50	0.48	9.75	1.95	3.90
	60	0.576	10.68	2.14	4.27
	70	0.672	11.53	2.31	4.61
	80	0.768	12.33	2.47	4.93
	90	0.864	13.08	2.62	5.23
	100	0.96	13.79	2.76	5.51
90	50	0.54	10.34	2.07	4.14
	60	0.648	11.33	2.27	4.53
	70	0.756	12.23	2.45	4.89
	80	0.864	13.08	2.62	5.23
	90	0.972	13.87	2.77	5.55
	100	1.08	14.62	2.92	5.85
100	50	0.6	10.90	2.18	4.36
	60	0.72	11.94	2.39	4.78
	70	0.84	12.90	2.58	5.16
	80	0.96	13.79	2.76	5.51
	90	1.08	14.62	2.92	5.85
	100	1.2	15.41	3.08	6.17
110	50	0.66	11.43	2.29	4.57
	60	0.792	12.52	2.50	5.01
	70	0.924	13.53	2.71	5.41
	80	1.056	14.46	2.89	5.78
	90	1.188	15.34	3.07	6.13
	100	1.32	16.17	3.23	6.47

1½" PEX pipe expansion arm

PEX with PEX-a Pipe Support and clevis hangers or loops has a thermal expansion rate of 0.12/10°F ΔT/100 ft. (3.05mm/5.56°C ΔT/30.48m).

Delta T (ΔT)	Run (ft)	Delta L (in)	Flexible arm length (in)	L1 (in)	L2 (in)
120	50	0.72	11.94	2.39	4.78
	60	0.864	13.08	2.62	5.23
	70	1.008	14.13	2.83	5.65
	80	1.152	15.10	3.02	6.04
	90	1.296	16.02	3.20	6.41
	100	1.44	16.89	3.38	6.75
130	50	0.78	12.43	2.49	4.97
	60	0.936	13.61	2.72	5.45
	70	1.092	14.70	2.94	5.88
	80	1.248	15.72	3.14	6.29
	90	1.404	16.67	3.33	6.67
	100	1.56	17.57	3.51	7.03
140	50	0.84	12.90	2.58	5.16
	60	1.008	14.13	2.83	5.65
	70	1.176	15.26	3.05	6.10
	80	1.344	16.31	3.26	6.53
	90	1.512	17.30	3.46	6.92
	100	1.68	18.24	3.65	7.30
150	50	0.9	13.35	2.67	5.34
	60	1.08	14.62	2.92	5.85
	70	1.26	15.79	3.16	6.32
	80	1.44	16.89	3.38	6.75
	90	1.62	17.91	3.58	7.16
	100	1.8	18.88	3.78	7.55
160	50	0.96	13.79	2.76	5.51
	60	1.152	15.10	3.02	6.04
	70	1.344	16.31	3.26	6.53
	80	1.536	17.44	3.49	6.98
	90	1.728	18.50	3.70	7.40
	100	1.92	19.50	3.90	7.80

1½" PEX pipe expansion arm

Delta T (ΔT)	Run (ft)	Delta L (in)	Flexible arm length (in)	L1 (in)	L2 (in)
10	50	0.06	3.75	0.75	1.50
	60	0.072	4.10	0.82	1.64
	70	0.084	4.43	0.89	1.77
	80	0.096	4.74	0.95	1.90
	90	0.108	5.03	1.01	2.01
	100	0.12	5.30	1.06	2.12

Table E-2: PEX pipe expansion arm calculations ½" to 3"

1½" PEX pipe expansion arm

PEX with PEX-a Pipe Support and clevis hangers or loops has a thermal expansion rate of 0.12/10°F ΔT/100 ft. (3.05mm/5.56°C ΔT/30.48m).

Delta T (ΔT)	Run (ft)	Delta L (in)	Flexible arm length (in)	L1 (in)	L2 (in)
20	50	0.12	5.30	1.06	2.12
	60	0.144	5.80	1.16	2.32
	70	0.168	6.27	1.25	2.51
	80	0.192	6.70	1.34	2.68
	90	0.216	7.11	1.42	2.84
	100	0.24	7.49	1.50	3.00
30	50	0.18	6.49	1.30	2.60
	60	0.216	7.11	1.42	2.84
	70	0.252	7.68	1.54	3.07
	80	0.288	8.21	1.64	3.28
	90	0.324	8.71	1.74	3.48
	100	0.36	9.18	1.84	3.67
40	50	0.24	7.49	1.50	3.00
	60	0.288	8.21	1.64	3.28
	70	0.336	8.87	1.77	3.55
	80	0.384	9.48	1.90	3.79
	90	0.432	10.05	2.01	4.02
	100	0.48	10.60	2.12	4.24
50	50	0.3	8.38	1.68	3.35
	60	0.36	9.18	1.84	3.67
	70	0.42	9.91	1.98	3.97
	80	0.48	10.60	2.12	4.24
	90	0.54	11.24	2.25	4.50
	100	0.6	11.85	2.37	4.74
60	50	0.36	9.18	1.84	3.67
	60	0.432	10.05	2.01	4.02
	70	0.504	10.86	2.17	4.34
	80	0.576	11.61	2.32	4.64
	90	0.648	12.31	2.46	4.93
	100	0.72	12.98	2.60	5.19
70	50	0.42	9.91	1.98	3.97
	60	0.504	10.86	2.17	4.34
	70	0.588	11.73	2.35	4.69
	80	0.672	12.54	2.51	5.02
	90	0.756	13.30	2.66	5.32
	100	0.84	14.02	2.80	5.61
80	50	0.48	10.60	2.12	4.24
	60	0.576	11.61	2.32	4.64
	70	0.672	12.54	2.51	5.02
	80	0.768	13.41	2.68	5.36
	90	0.864	14.22	2.84	5.69
	100	0.96	14.99	3.00	6.00

1½" PEX pipe expansion arm

PEX with PEX-a Pipe Support and clevis hangers or loops has a thermal expansion rate of 0.12/10°F ΔT/100 ft. (3.05mm/5.56°C ΔT/30.48m).

Delta T (ΔT)	Run (ft)	Delta L (in)	Flexible arm length (in)	L1 (in)	L2 (in)
90	50	0.54	11.24	2.25	4.50
	60	0.648	12.31	2.46	4.93
	70	0.756	13.30	2.66	5.32
	80	0.864	14.22	2.84	5.69
	90	0.972	15.08	3.02	6.03
	100	1.08	15.90	3.18	6.36
100	50	0.6	11.85	2.37	4.74
	60	0.72	12.98	2.60	5.19
	70	0.84	14.02	2.80	5.61
	80	0.96	14.99	3.00	6.00
	90	1.08	15.90	3.18	6.36
	100	1.2	16.76	3.35	6.70
110	50	0.66	12.43	2.49	4.97
	60	0.792	13.61	2.72	5.45
	70	0.924	14.70	2.94	5.88
	80	1.056	15.72	3.14	6.29
	90	1.188	16.67	3.33	6.67
	100	1.32	17.57	3.51	7.03
120	50	0.72	12.98	2.60	5.19
	60	0.864	14.22	2.84	5.69
	70	1.008	15.36	3.07	6.14
	80	1.152	16.42	3.28	6.57
	90	1.296	17.41	3.48	6.97
	100	1.44	18.36	3.67	7.34
130	50	0.78	13.51	2.70	5.40
	60	0.936	14.80	2.96	5.92
	70	1.092	15.99	3.20	6.39
	80	1.248	17.09	3.42	6.84
	90	1.404	18.13	3.63	7.25
	100	1.56	19.11	3.82	7.64
140	50	0.84	14.02	2.80	5.61
	60	1.008	15.36	3.07	6.14
	70	1.176	16.59	3.32	6.64
	80	1.344	17.73	3.55	7.09
	90	1.512	18.81	3.76	7.52
	100	1.68	19.83	3.97	7.93
150	50	0.9	14.51	2.90	5.80
	60	1.08	15.90	3.18	6.36
	70	1.26	17.17	3.43	6.87
	80	1.44	18.36	3.67	7.34
	90	1.62	19.47	3.89	7.79
	100	1.8	20.52	4.10	8.21

Table E-2: PEX pipe expansion arm calculations ½" to 3"

1½" PEX pipe expansion arm

Delta T (ΔT)	Run (ft)	Delta L (in)	Flexible arm length (in)	L1 (in)	L2 (in)
160	50	0.96	14.99	3.00	6.00
	60	1.152	16.42	3.28	6.57
	70	1.344	17.73	3.55	7.09
	80	1.536	18.96	3.79	7.58
	90	1.728	20.11	4.02	8.04
	100	1.92	21.20	4.24	8.48

2" PEX pipe expansion arm

Delta T (ΔT)	Run (ft)	Delta L (in)	Flexible arm length (in)	L1 (in)	L2 (in)
10	50	0.06	4.28	0.86	1.71
	60	0.072	4.69	0.94	1.88
	70	0.084	5.07	1.01	2.03
	80	0.096	5.42	1.08	2.17
	90	0.108	5.75	1.15	2.30
	100	0.12	6.06	1.21	2.42
20	50	0.12	6.06	1.21	2.42
	60	0.144	6.64	1.33	2.66
	70	0.168	7.17	1.43	2.87
	80	0.192	7.66	1.53	3.07
	90	0.216	8.13	1.63	3.25
30	100	0.24	8.57	1.71	3.43
	50	0.18	7.42	1.48	2.97
	60	0.216	8.13	1.63	3.25
	70	0.252	8.78	1.76	3.51
	80	0.288	9.39	1.88	3.76
40	90	0.324	9.96	1.99	3.98
	100	0.36	10.50	2.10	4.20
	50	0.24	8.57	1.71	3.43
	60	0.288	9.39	1.88	3.76
	70	0.336	10.14	2.03	4.06
50	80	0.384	10.84	2.17	4.34
	90	0.432	11.50	2.30	4.60
	100	0.48	12.12	2.42	4.85
	50	0.3	9.58	1.92	3.83
	60	0.36	10.50	2.10	4.20
50	70	0.42	11.34	2.27	4.53
	80	0.48	12.12	2.42	4.85
	90	0.54	12.85	2.57	5.14
	100	0.6	13.55	2.71	5.42

2" PEX pipe expansion arm

Delta T (ΔT)	Run (ft)	Delta L (in)	Flexible arm length (in)	L1 (in)	L2 (in)
60	50	0.36	10.50	2.10	4.20
	60	0.432	11.50	2.30	4.60
	70	0.504	12.42	2.48	4.97
	80	0.576	13.28	2.66	5.31
	90	0.648	14.08	2.82	5.63
	100	0.72	14.84	2.97	5.94
70	50	0.42	11.34	2.27	4.53
	60	0.504	12.42	2.48	4.97
	70	0.588	13.41	2.68	5.37
	80	0.672	14.34	2.87	5.74
	90	0.756	15.21	3.04	6.08
80	100	0.84	16.03	3.21	6.41
	50	0.48	12.12	2.42	4.85
	60	0.576	13.28	2.66	5.31
	70	0.672	14.34	2.87	5.74
	80	0.768	15.33	3.07	6.13
90	90	0.864	16.26	3.25	6.50
	100	0.96	17.14	3.43	6.86
	50	0.54	12.85	2.57	5.14
	60	0.648	14.08	2.82	5.63
	70	0.756	15.21	3.04	6.08
100	80	0.864	16.26	3.25	6.50
	90	0.972	17.25	3.45	6.90
	100	1.08	18.18	3.64	7.27
	50	0.6	13.55	2.71	5.42
	60	0.72	14.84	2.97	5.94
110	70	0.84	16.03	3.21	6.41
	80	0.96	17.14	3.43	6.86
	90	1.08	18.18	3.64	7.27
	100	1.2	19.16	3.83	7.66
	50	0.66	14.21	2.84	5.68
120	60	0.792	15.57	3.11	6.23
	70	0.924	16.81	3.36	6.73
	80	1.056	17.98	3.60	7.19
	90	1.188	19.07	3.81	7.63
	100	1.32	20.10	4.02	8.04
120	50	0.72	14.84	2.97	5.94
	60	0.864	16.26	3.25	6.50
	70	1.008	17.56	3.51	7.03
	80	1.152	18.78	3.76	7.51
	90	1.296	19.91	3.98	7.97
100	1.44	20.99	4.20	8.40	

PEX with PEX-a Pipe Support and clevis hangers or loops has a thermal expansion rate of 0.12/10°F ΔT/100 ft. (3.05mm/5.56°C ΔT/30.48m).

Table E-2: PEX pipe expansion arm calculations ½" to 3"

2" PEX pipe expansion arm

Delta T (ΔT)	Run (ft)	Delta L (in)	Flexible arm length (in)	L1 (in)	L2 (in)
130	50	0.78	15.45	3.09	6.18
	60	0.936	16.92	3.38	6.77
	70	1.092	18.28	3.66	7.31
	80	1.248	19.54	3.91	7.82
	90	1.404	20.73	4.15	8.29
	100	1.56	21.85	4.37	8.74
140	50	0.84	16.03	3.21	6.41
	60	1.008	17.56	3.51	7.03
	70	1.176	18.97	3.79	7.59
	80	1.344	20.28	4.06	8.11
	90	1.512	21.51	4.30	8.60
	100	1.68	22.67	4.53	9.07
150	50	0.9	16.60	3.32	6.64
	60	1.08	18.18	3.64	7.27
	70	1.26	19.64	3.93	7.85
	80	1.44	20.99	4.20	8.40
	90	1.62	22.26	4.45	8.91
	100	1.8	23.47	4.69	9.39
160	50	0.96	17.14	3.43	6.86
	60	1.152	18.78	3.76	7.51
	70	1.344	20.28	4.06	8.11
	80	1.536	21.68	4.34	8.67
	90	1.728	22.99	4.60	9.20
	100	1.92	24.24	4.85	9.70

PEX with PEX-a Pipe Support and clevis hangers or loops has a thermal expansion rate of 0.12/10°F ΔT/100 ft. (3.05mm/5.56°C ΔT/30.48m).

Table E-2: PEX pipe expansion arm calculations ½" to 3"

2½" PEX pipe expansion arm

Delta T (ΔT)	Run (ft)	Delta L (in)	Flexible arm length (in)	L1 (in)	L2 (in)
10	50	0.06	4.76	0.95	1.90
	60	0.072	5.22	1.04	2.09
	70	0.084	5.63	1.13	2.25
	80	0.096	6.02	1.20	2.41
	90	0.108	6.39	1.28	2.56
	100	0.12	6.73	1.35	2.69
20	50	0.12	6.73	1.35	2.69
	60	0.144	7.38	1.48	2.95
	70	0.168	7.97	1.59	3.19
	80	0.192	8.52	1.70	3.41
	90	0.216	9.04	1.81	3.61
	100	0.24	9.52	1.90	3.81

PEX with PEX-a Pipe Support and clevis hangers or loops

Table E-2: PEX pipe expansion arm calculations ½" to 3"

2½" PEX pipe expansion arm

Delta T (ΔT)	Run (ft)	Delta L (in)	Flexible arm length (in)	L1 (in)	L2 (in)
30	50	0.18	8.25	1.65	3.30
	60	0.216	9.04	1.81	3.61
	70	0.252	9.76	1.95	3.90
	80	0.288	10.43	2.09	4.17
	90	0.324	11.07	2.21	4.43
	100	0.36	11.67	2.33	4.67
40	50	0.24	9.52	1.90	3.81
	60	0.288	10.43	2.09	4.17
	70	0.336	11.27	2.25	4.51
	80	0.384	12.05	2.41	4.82
	90	0.432	12.78	2.56	5.11
	100	0.48	13.47	2.69	5.39
50	50	0.3	10.65	2.13	4.26
	60	0.36	11.67	2.33	4.67
	70	0.42	12.60	2.52	5.04
	80	0.48	13.47	2.69	5.39
	90	0.54	14.29	2.86	5.71
	100	0.6	15.06	3.01	6.02
60	50	0.36	11.67	2.33	4.67
	60	0.432	12.78	2.56	5.11
	70	0.504	13.80	2.76	5.52
	80	0.576	14.76	2.95	5.90
	90	0.648	15.65	3.13	6.26
	100	0.72	16.50	3.30	6.60
70	50	0.42	12.60	2.52	5.04
	60	0.504	13.80	2.76	5.52
	70	0.588	14.91	2.98	5.96
	80	0.672	15.94	3.19	6.38
	90	0.756	16.90	3.38	6.76
	100	0.84	17.82	3.56	7.13
80	50	0.48	13.47	2.69	5.39
	60	0.576	14.76	2.95	5.90
	70	0.672	15.94	3.19	6.38
	80	0.768	17.04	3.41	6.82
	90	0.864	18.07	3.61	7.23
	100	0.96	19.05	3.81	7.62
90	50	0.54	14.29	2.86	5.71
	60	0.648	15.65	3.13	6.26
	70	0.756	16.90	3.38	6.76
	80	0.864	18.07	3.61	7.23
	90	0.972	19.17	3.83	7.67
	100	1.08	20.20	4.04	8.08

PEX with PEX-a Pipe Support and clevis hangers or loops has a thermal expansion rate of 0.12/10°F ΔT/100 ft. (3.05mm/5.56°C ΔT/30.48m).

2½" PEX pipe expansion arm

Delta T (ΔT)	Run (ft)	Delta L (in)	Flexible arm length (in)	L1 (in)	L2 (in)
100	50	0.6	15.06	3.01	6.02
	60	0.72	16.50	3.30	6.60
	70	0.84	17.82	3.56	7.13
	80	0.96	19.05	3.81	7.62
	90	1.08	20.20	4.04	8.08
	100	1.2	21.30	4.26	8.52
110	50	0.66	15.79	3.16	6.32
	60	0.792	17.30	3.46	6.92
	70	0.924	18.69	3.74	7.48
	80	1.056	19.98	4.00	7.99
	90	1.188	21.19	4.24	8.48
	100	1.32	22.34	4.47	8.93
120	50	0.72	16.50	3.30	6.60
	60	0.864	18.07	3.61	7.23
	70	1.008	19.52	3.90	7.81
	80	1.152	20.87	4.17	8.35
	90	1.296	22.13	4.43	8.85
	100	1.44	23.33	4.67	9.33
130	50	0.78	17.17	3.43	6.87
	60	0.936	18.81	3.76	7.52
	70	1.092	20.32	4.06	8.13
	80	1.248	21.72	4.34	8.69
	90	1.404	23.04	4.61	9.21
	100	1.56	24.28	4.86	9.71
140	50	0.84	17.82	3.56	7.13
	60	1.008	19.52	3.90	7.81
	70	1.176	21.08	4.22	8.43
	80	1.344	22.54	4.51	9.02
	90	1.512	23.91	4.78	9.56
	100	1.68	25.20	5.04	10.08
150	50	0.9	18.44	3.69	7.38
	60	1.08	20.20	4.04	8.08
	70	1.26	21.82	4.36	8.73
	80	1.44	23.33	4.67	9.33
	90	1.62	24.75	4.95	9.90
	100	1.8	26.08	5.22	10.43
160	50	0.96	19.05	3.81	7.62
	60	1.152	20.87	4.17	8.35
	70	1.344	22.54	4.51	9.02
	80	1.536	24.10	4.82	9.64
	90	1.728	25.56	5.11	10.22
	100	1.92	26.94	5.39	10.78

PEX with PEX-a Pipe Support and clevis hangers or loops has a thermal expansion rate of 0.12/10°F ΔT/100 ft. (3.05mm/5.56°C ΔT/30.48m).

3" PEX pipe expansion arm

Delta T (ΔT)	Run (ft)	Delta L (in)	Flexible arm length (in)	L1 (in)	L2 (in)
10	50	0.06	5.20	1.04	2.08
	60	0.072	5.69	1.14	2.28
	70	0.084	6.15	1.23	2.46
	80	0.096	6.57	1.31	2.63
	90	0.108	6.97	1.39	2.79
	100	0.12	7.35	1.47	2.94
20	50	0.12	7.35	1.47	2.94
	60	0.144	8.05	1.61	3.22
	70	0.168	8.69	1.74	3.48
	80	0.192	9.30	1.86	3.72
	90	0.216	9.86	1.97	3.94
	100	0.24	10.39	2.08	4.16
30	50	0.18	9.00	1.80	3.60
	60	0.216	9.86	1.97	3.94
	70	0.252	10.65	2.13	4.26
	80	0.288	11.38	2.28	4.55
	90	0.324	12.07	2.41	4.83
	100	0.36	12.73	2.55	5.09
40	50	0.24	10.39	2.08	4.16
	60	0.288	11.38	2.28	4.55
	70	0.336	12.30	2.46	4.92
	80	0.384	13.15	2.63	5.26
	90	0.432	13.94	2.79	5.58
	100	0.48	14.70	2.94	5.88
50	50	0.3	11.62	2.32	4.65
	60	0.36	12.73	2.55	5.09
	70	0.42	13.75	2.75	5.50
	80	0.48	14.70	2.94	5.88
	90	0.54	15.59	3.12	6.24
	100	0.6	16.43	3.29	6.57
60	50	0.36	12.73	2.55	5.09
	60	0.432	13.94	2.79	5.58
	70	0.504	15.06	3.01	6.02
	80	0.576	16.10	3.22	6.44
	90	0.648	17.08	3.42	6.83
	100	0.72	18.00	3.60	7.20
70	50	0.42	13.75	2.75	5.50
	60	0.504	15.06	3.01	6.02
	70	0.588	16.27	3.25	6.51
	80	0.672	17.39	3.48	6.96
	90	0.756	18.44	3.69	7.38
	100	0.84	19.44	3.89	7.78

PEX with PEX-a Pipe Support and clevis hangers or loops has a thermal expansion rate of 0.12/10°F ΔT/100 ft. (3.05mm/5.56°C ΔT/30.48m).

Table E-2: PEX pipe expansion arm calculations ½" to 3"

3" PEX pipe expansion arm

Delta T (ΔT)	Run (ft)	Delta L (in)	Flexible arm length (in)	L1 (in)	L2 (in)
80	50	0.48	14.70	2.94	5.88
	60	0.576	16.10	3.22	6.44
	70	0.672	17.39	3.48	6.96
	80	0.768	18.59	3.72	7.44
	90	0.864	19.72	3.94	7.89
	100	0.96	20.78	4.16	8.31
90	50	0.54	15.59	3.12	6.24
	60	0.648	17.08	3.42	6.83
	70	0.756	18.44	3.69	7.38
	80	0.864	19.72	3.94	7.89
	90	0.972	20.91	4.18	8.37
	100	1.08	22.05	4.41	8.82
100	50	0.6	16.43	3.29	6.57
	60	0.72	18.00	3.60	7.20
	70	0.84	19.44	3.89	7.78
	80	0.96	20.78	4.16	8.31
	90	1.08	22.05	4.41	8.82
	100	1.2	23.24	4.65	9.30
110	50	0.66	17.23	3.45	6.89
	60	0.792	18.88	3.78	7.55
	70	0.924	20.39	4.08	8.16
	80	1.056	21.80	4.36	8.72
	90	1.188	23.12	4.62	9.25
	100	1.32	24.37	4.87	9.75
120	50	0.72	18.00	3.60	7.20
	60	0.864	19.72	3.94	7.89
	70	1.008	21.30	4.26	8.52
	80	1.152	22.77	4.55	9.11
	90	1.296	24.15	4.83	9.66
	100	1.44	25.46	5.09	10.18
130	50	0.78	18.73	3.75	7.49
	60	0.936	20.52	4.10	8.21
	70	1.092	22.17	4.43	8.87
	80	1.248	23.70	4.74	9.48
	90	1.404	25.14	5.03	10.05
	100	1.56	26.50	5.30	10.60
140	50	0.84	19.44	3.89	7.78
	60	1.008	21.30	4.26	8.52
	70	1.176	23.00	4.60	9.20
	80	1.344	24.59	4.92	9.84
	90	1.512	26.08	5.22	10.43
	100	1.68	27.50	5.50	11.00

PEX with PEX-a Pipe Support and clevis hangers or loops has a thermal expansion rate of 0.12/10°F ΔT/100 ft. (3.05mm/5.56°C ΔT/30.48m).

3" PEX pipe expansion arm

Delta T (ΔT)	Run (ft)	Delta L (in)	Flexible arm length (in)	L1 (in)	L2 (in)
150	50	0.9	20.12	4.02	8.05
	60	1.08	22.05	4.41	8.82
	70	1.26	23.81	4.76	9.52
	80	1.44	25.46	5.09	10.18
	90	1.62	27.00	5.40	10.80
	100	1.8	28.46	5.69	11.38
160	50	0.96	20.78	4.16	8.31
	60	1.152	22.77	4.55	9.11
	70	1.344	24.59	4.92	9.84
	80	1.536	26.29	5.26	10.52
	90	1.728	27.89	5.58	11.15
	100	1.92	29.39	5.88	11.76

PEX with PEX-a Pipe Support and clevis hangers or loops

Table E-2: PEX pipe expansion arm calculations ½" to 3"

PEX has a free-body

thermal expansion rate of 1.1"/10°F ΔT/100 ft. (27.94mm/5.56°C ΔT/30.48m)

½" PEX pipe expansion arm

PEX has a free-body thermal expansion rate of 1.1"/10°F ΔT/100 ft. (27.94mm/5.56°C ΔT/30.48m).	Delta T (ΔT)	Run (ft)	Delta L (in)	Flexible arm length (in)	L1 (in)	L2 (in)
	10	50	0.55	7.04	1.41	2.81
		60	0.66	7.71	1.54	3.08
		70	0.77	8.32	1.66	3.33
		80	0.88	8.90	1.78	3.56
		90	0.99	9.44	1.89	3.78
	20	100	1.1	9.95	1.99	3.98
		50	1.1	9.95	1.99	3.98
		60	1.32	10.90	2.18	4.36
		70	1.54	11.77	2.35	4.71
80		1.76	12.59	2.52	5.03	
30	90	1.98	13.35	2.67	5.34	
	100	2.2	14.07	2.81	5.63	
	50	1.65	12.19	2.44	4.87	
	60	1.98	13.35	2.67	5.34	
	70	2.31	14.42	2.88	5.77	
40	80	2.64	15.41	3.08	6.17	
	90	2.97	16.35	3.27	6.54	
	100	3.3	17.23	3.45	6.89	
	50	2.2	14.07	2.81	5.63	
	60	2.64	15.41	3.08	6.17	
50	70	3.08	16.65	3.33	6.66	
	80	3.52	17.80	3.56	7.12	
	90	3.96	18.88	3.78	7.55	
	100	4.4	19.90	3.98	7.96	
	50	2.75	15.73	3.15	6.29	
60	60	3.3	17.23	3.45	6.89	
	70	3.85	18.61	3.72	7.45	
	80	4.4	19.90	3.98	7.96	
	90	4.95	21.11	4.22	8.44	
	100	5.5	22.25	4.45	8.90	
60	50	3.3	17.23	3.45	6.89	
	60	3.96	18.88	3.78	7.55	
	70	4.62	20.39	4.08	8.16	
	80	5.28	21.80	4.36	8.72	
	90	5.94	23.12	4.62	9.25	
100	6.6	24.37	4.87	9.75		

½" PEX pipe expansion arm

PEX has a free-body thermal expansion rate of 1.1"/10°F ΔT/100 ft. (27.94mm/5.56°C ΔT/30.48m).	Delta T (ΔT)	Run (ft)	Delta L (in)	Flexible arm length (in)	L1 (in)	L2 (in)
	70	50	3.85	18.61	3.72	7.45
		60	4.62	20.39	4.08	8.16
		70	5.39	22.02	4.40	8.81
		80	6.16	23.55	4.71	9.42
		90	6.93	24.97	4.99	9.99
	80	100	7.7	26.32	5.26	10.53
		50	4.4	19.90	3.98	7.96
		60	5.28	21.80	4.36	8.72
		70	6.16	23.55	4.71	9.42
80		7.04	25.17	5.03	10.07	
90	90	7.92	26.70	5.34	10.68	
	100	8.8	28.14	5.63	11.26	
	50	4.95	21.11	4.22	8.44	
	60	5.94	23.12	4.62	9.25	
	70	6.93	24.97	4.99	9.99	
100	80	7.92	26.70	5.34	10.68	
	90	8.91	28.32	5.66	11.33	
	100	9.9	29.85	5.97	11.94	
	50	5.5	22.25	4.45	8.90	
	60	6.6	24.37	4.87	9.75	
110	70	7.7	26.32	5.26	10.53	
	80	8.8	28.14	5.63	11.26	
	90	9.9	29.85	5.97	11.94	
	100	11	31.46	6.29	12.59	
	50	6.05	23.33	4.67	9.33	
120	60	7.26	25.56	5.11	10.22	
	70	8.47	27.61	5.52	11.04	
	80	9.68	29.52	5.90	11.81	
	90	10.89	31.31	6.26	12.52	
	100	12.1	33.00	6.60	13.20	
120	50	6.6	24.37	4.87	9.75	
	60	7.92	26.70	5.34	10.68	
	70	9.24	28.84	5.77	11.53	
	80	10.56	30.83	6.17	12.33	
	90	11.88	32.70	6.54	13.08	
100	13.2	34.47	6.89	13.79		

Table E-3: PEX pipe expansion arm calculations ½" to 3"

½" PEX pipe expansion arm

PEX has a free-body thermal expansion rate of 1.1"/10°F ΔT/100 ft. (27.94mm/5.56°C ΔT/30.48m).

Delta T (ΔT)	Run (ft)	Delta L (in)	Flexible arm length (in)	L1 (in)	L2 (in)
130	50	7.15	25.37	5.07	10.15
	60	8.58	27.79	5.56	11.12
	70	10.01	30.01	6.00	12.01
	80	11.44	32.09	6.42	12.83
	90	12.87	34.03	6.81	13.61
	100	14.3	35.87	7.17	14.35
140	50	7.7	26.32	5.26	10.53
	60	9.24	28.84	5.77	11.53
	70	10.78	31.15	6.23	12.46
	80	12.32	33.30	6.66	13.32
	90	13.86	35.32	7.06	14.13
	100	15.4	37.23	7.45	14.89
150	50	8.25	27.25	5.45	10.90
	60	9.9	29.85	5.97	11.94
	70	11.55	32.24	6.45	12.90
	80	13.2	34.47	6.89	13.79
	90	14.85	36.56	7.31	14.62
	100	16.5	38.54	7.71	15.41
160	50	8.8	28.14	5.63	11.26
	60	10.56	30.83	6.17	12.33
	70	12.32	33.30	6.66	13.32
	80	14.08	35.60	7.12	14.24
	90	15.84	37.76	7.55	15.10
	100	17.6	39.80	7.96	15.92

Table E-3: PEX pipe expansion arm calculations ½" to 3"

¾" PEX pipe expansion arm

PEX has a free-body thermal expansion rate of 1.1"/10°F ΔT/100 ft. (27.94mm/5.56°C ΔT/30.48m).

Delta T (ΔT)	Run (ft)	Delta L (in)	Flexible arm length (in)	L1 (in)	L2 (in)
30	50	1.65	14.42	2.88	5.77
	60	1.98	15.79	3.16	6.32
	70	2.31	17.06	3.41	6.82
	80	2.64	18.24	3.65	7.30
	90	2.97	19.34	3.87	7.74
	100	3.3	20.39	4.08	8.16
40	50	2.2	16.65	3.33	6.66
	60	2.64	18.24	3.65	7.30
	70	3.08	19.70	3.94	7.88
	80	3.52	21.06	4.21	8.42
	90	3.96	22.34	4.47	8.93
	100	4.4	23.55	4.71	9.42
50	50	2.75	18.61	3.72	7.45
	60	3.3	20.39	4.08	8.16
	70	3.85	22.02	4.40	8.81
	80	4.4	23.55	4.71	9.42
	90	4.95	24.97	4.99	9.99
	100	5.5	26.32	5.26	10.53
60	50	3.3	20.39	4.08	8.16
	60	3.96	22.34	4.47	8.93
	70	4.62	24.13	4.83	9.65
	80	5.28	25.79	5.16	10.32
	90	5.94	27.36	5.47	10.94
	100	6.6	28.84	5.77	11.53
70	50	3.85	22.02	4.40	8.81
	60	4.62	24.13	4.83	9.65
	70	5.39	26.06	5.21	10.42
	80	6.16	27.86	5.57	11.14
	90	6.93	29.55	5.91	11.82
	100	7.7	31.15	6.23	12.46
80	50	4.4	23.55	4.71	9.42
	60	5.28	25.79	5.16	10.32
	70	6.16	27.86	5.57	11.14
	80	7.04	29.78	5.96	11.91
	90	7.92	31.59	6.32	12.64
	100	8.8	33.30	6.66	13.32
90	50	4.95	24.97	4.99	9.99
	60	5.94	27.36	5.47	10.94
	70	6.93	29.55	5.91	11.82
	80	7.92	31.59	6.32	12.64
	90	8.91	33.51	6.70	13.40
	100	9.9	35.32	7.06	14.13

Table E-3: PEX pipe expansion arm calculations ½" to 3"

¾" PEX pipe expansion arm

PEX has a free-body thermal expansion rate of 1.1"/10°F ΔT/100 ft. (27.94mm/5.56°C ΔT/30.48m).

Delta T (ΔT)	Run (ft)	Delta L (in)	Flexible arm length (in)	L1 (in)	L2 (in)
10	50	0.55	8.32	1.66	3.33
	60	0.66	9.12	1.82	3.65
	70	0.77	9.85	1.97	3.94
	80	0.88	10.53	2.11	4.21
	90	0.99	11.17	2.23	4.47
	100	1.1	11.77	2.35	4.71
20	50	1.1	11.77	2.35	4.71
	60	1.32	12.90	2.58	5.16
	70	1.54	13.93	2.79	5.57
	80	1.76	14.89	2.98	5.96
	90	1.98	15.79	3.16	6.32
	100	2.2	16.65	3.33	6.66

Table E-3: PEX pipe expansion arm calculations ½" to 3"

¾" PEX pipe expansion arm

PEX has a free-body thermal expansion rate of 1.1"/10°F ΔT/100 ft. (27.94mm/5.56°C ΔT/30.48m).

Delta T (ΔT)	Run (ft)	Delta L (in)	Flexible arm length (in)	L1 (in)	L2 (in)
100	50	5.5	26.32	5.26	10.53
	60	6.6	28.84	5.77	11.53
	70	7.7	31.15	6.23	12.46
	80	8.8	33.30	6.66	13.32
	90	9.9	35.32	7.06	14.13
110	100	11	37.23	7.45	14.89
	50	6.05	27.61	5.52	11.04
	60	7.26	30.24	6.05	12.10
	70	8.47	32.67	6.53	13.07
	80	9.68	34.92	6.98	13.97
120	90	10.89	37.04	7.41	14.82
	100	12.1	39.05	7.81	15.62
	50	6.6	28.84	5.77	11.53
	60	7.92	31.59	6.32	12.64
	70	9.24	34.12	6.82	13.65
130	80	10.56	36.48	7.30	14.59
	90	11.88	38.69	7.74	15.48
	100	13.2	40.78	8.16	16.31
	50	7.15	30.01	6.00	12.01
	60	8.58	32.88	6.58	13.15
140	70	10.01	35.51	7.10	14.21
	80	11.44	37.97	7.59	15.19
	90	12.87	40.27	8.05	16.11
	100	14.3	42.45	8.49	16.98
	50	7.7	31.15	6.23	12.46
150	60	9.24	34.12	6.82	13.65
	70	10.78	36.85	7.37	14.74
	80	12.32	39.40	7.88	15.76
	90	13.86	41.79	8.36	16.72
	100	15.4	44.05	8.81	17.62
160	50	8.25	32.24	6.45	12.90
	60	9.9	35.32	7.06	14.13
	70	11.55	38.15	7.63	15.26
	80	13.2	40.78	8.16	16.31
	90	14.85	43.26	8.65	17.30
	100	16.5	45.60	9.12	18.24
	50	8.8	33.30	6.66	13.32
	60	10.56	36.48	7.30	14.59
	70	12.32	39.40	7.88	15.76
	80	14.08	42.12	8.42	16.85
	90	15.84	44.67	8.93	17.87
	100	17.6	47.09	9.42	18.84

1" PEX pipe expansion arm

PEX has a free-body thermal expansion rate of 1.1"/10°F ΔT/100 ft. (27.94mm/5.56°C ΔT/30.48m).

Delta T (ΔT)	Run (ft)	Delta L (in)	Flexible arm length (in)	L1 (in)	L2 (in)
10	50	0.55	9.44	1.89	3.78
	60	0.66	10.34	2.07	4.14
	70	0.77	11.17	2.23	4.47
	80	0.88	11.94	2.39	4.78
	90	0.99	12.66	2.53	5.07
20	100	1.1	13.35	2.67	5.34
	50	1.1	13.35	2.67	5.34
	60	1.32	14.62	2.92	5.85
	70	1.54	15.79	3.16	6.32
	80	1.76	16.89	3.38	6.75
30	90	1.98	17.91	3.58	7.16
	100	2.2	18.88	3.78	7.55
	50	1.65	16.35	3.27	6.54
	60	1.98	17.91	3.58	7.16
	70	2.31	19.34	3.87	7.74
40	80	2.64	20.68	4.14	8.27
	90	2.97	21.93	4.39	8.77
	100	3.3	23.12	4.62	9.25
	50	2.2	18.88	3.78	7.55
	60	0.66	10.34	2.07	4.14
50	70	0.77	11.17	2.23	4.47
	80	0.88	11.94	2.39	4.78
	90	0.99	12.66	2.53	5.07
	100	1.1	13.35	2.67	5.34
	50	2.75	21.11	4.22	8.44
60	60	3.3	23.12	4.62	9.25
	70	3.85	24.97	4.99	9.99
	80	4.4	26.70	5.34	10.68
	90	4.95	28.32	5.66	11.33
	100	5.5	29.85	5.97	11.94
70	50	3.3	23.12	4.62	9.25
	60	3.96	25.33	5.07	10.13
	70	4.62	27.36	5.47	10.94
	80	5.28	29.25	5.85	11.70
	90	5.94	31.02	6.20	12.41
	100	6.6	32.70	6.54	13.08
	50	3.85	24.97	4.99	9.99
	60	4.62	27.36	5.47	10.94
	70	5.39	29.55	5.91	11.82
	80	6.16	31.59	6.32	12.64
	90	6.93	33.51	6.70	13.40
	100	7.7	35.32	7.06	14.13

Table E-3: PEX pipe expansion arm calculations ½" to 3"

1" PEX pipe expansion arm

PEX has a free-body thermal expansion rate of 1.1"/10°F ΔT/100 ft. (27.94mm/5.56°C ΔT/30.48m).

Delta T (ΔT)	Run (ft)	Delta L (in)	Flexible arm length (in)	L1 (in)	L2 (in)
80	50	4.4	26.70	5.34	10.68
	60	5.28	29.25	5.85	11.70
	70	6.16	31.59	6.32	12.64
	80	7.04	33.77	6.75	13.51
	90	7.92	35.82	7.16	14.33
	100	8.8	37.76	7.55	15.10
90	50	0.55	9.44	1.89	3.78
	60	0.66	10.34	2.07	4.14
	70	0.77	11.17	2.23	4.47
	80	0.88	11.94	2.39	4.78
	90	0.99	12.66	2.53	5.07
	100	1.1	13.35	2.67	5.34
100	50	1.1	13.35	2.67	5.34
	60	1.32	14.62	2.92	5.85
	70	1.54	15.79	3.16	6.32
	80	1.76	16.89	3.38	6.75
	90	1.98	17.91	3.58	7.16
	100	2.2	18.88	3.78	7.55
110	50	6.05	31.31	6.26	12.52
	60	7.26	34.29	6.86	13.72
	70	8.47	37.04	7.41	14.82
	80	9.68	39.60	7.92	15.84
	90	10.89	42.00	8.40	16.80
	100	12.1	44.27	8.85	17.71
120	50	6.6	32.70	6.54	13.08
	60	7.92	35.82	7.16	14.33
	70	9.24	38.69	7.74	15.48
	80	10.56	41.36	8.27	16.54
	90	11.88	43.87	8.77	17.55
	100	13.2	46.24	9.25	18.50
130	50	7.15	34.03	6.81	13.61
	60	8.58	37.28	7.46	14.91
	70	10.01	40.27	8.05	16.11
	80	11.44	43.05	8.61	17.22
	90	12.87	45.66	9.13	18.26
	100	14.3	48.13	9.63	19.25
140	50	7.7	35.32	7.06	14.13
	60	9.24	38.69	7.74	15.48
	70	10.78	41.79	8.36	16.72
	80	12.32	44.67	8.93	17.87
	90	13.86	47.38	9.48	18.95
	100	15.4	49.95	9.99	19.98

1" PEX pipe expansion arm

PEX has a free-body thermal expansion rate of 1.1"/10°F ΔT/100 ft. (27.94mm/5.56°C ΔT/30.48m).

Delta T (ΔT)	Run (ft)	Delta L (in)	Flexible arm length (in)	L1 (in)	L2 (in)
150	50	8.25	36.56	7.31	14.62
	60	9.9	40.05	8.01	16.02
	70	11.55	43.26	8.65	17.30
	80	13.2	46.24	9.25	18.50
	90	14.85	49.05	9.81	19.62
	100	16.5	51.70	10.34	20.68
160	50	8.8	37.76	7.55	15.10
	60	10.56	41.36	8.27	16.54
	70	12.32	44.67	8.93	17.87
	80	14.08	47.76	9.55	19.10
	90	15.84	50.66	10.13	20.26
	100	17.6	53.40	10.68	21.36

1¼" PEX pipe expansion arm

PEX has a free-body thermal expansion rate of 1.1"/10°F ΔT/100 ft. (27.94mm/5.56°C ΔT/30.48m).

Delta T (ΔT)	Run (ft)	Delta L (in)	Flexible arm length (in)	L1 (in)	L2 (in)
10	50	0.55	10.44	2.09	4.17
	60	0.66	11.43	2.29	4.57
	70	0.77	12.35	2.47	4.94
	80	0.88	13.20	2.64	5.28
	90	0.99	14.00	2.80	5.60
	100	1.1	14.76	2.95	5.90
20	50	0.55	10.44	2.09	4.17
	60	0.66	11.43	2.29	4.57
	70	0.77	12.35	2.47	4.94
	80	0.88	13.20	2.64	5.28
	90	0.99	14.00	2.80	5.60
	100	1.1	14.76	2.95	5.90
30	50	1.1	14.76	2.95	5.90
	60	1.32	16.17	3.23	6.47
	70	1.54	17.46	3.49	6.98
	80	1.76	18.67	3.73	7.47
	90	1.98	19.80	3.96	7.92
	100	2.2	20.87	4.17	8.35
40	50	1.65	18.07	3.61	7.23
	60	1.98	19.80	3.96	7.92
	70	2.31	21.39	4.28	8.55
	80	2.64	22.86	4.57	9.15
	90	2.97	24.25	4.85	9.70
	100	3.3	25.56	5.11	10.22

Table E-3: PEX pipe expansion arm calculations ½" to 3"

1¼" PEX pipe expansion arm

PEX has a free-body thermal expansion rate of 1.1"/10°F ΔT/100 ft. (27.94mm/5.56°C ΔT/30.48m).

Delta T (ΔT)	Run (ft)	Delta L (in)	Flexible arm length (in)	L1 (in)	L2 (in)
50	50	2.2	20.87	4.17	8.35
	60	2.64	22.86	4.57	9.15
	70	3.08	24.69	4.94	9.88
	80	3.52	26.40	5.28	10.56
	90	3.96	28.00	5.60	11.20
	100	4.4	29.52	5.90	11.81
60	50	2.75	23.33	4.67	9.33
	60	3.3	25.56	5.11	10.22
	70	3.85	27.61	5.52	11.04
	80	4.4	29.52	5.90	11.81
	90	4.95	31.31	6.26	12.52
	100	5.5	33.00	6.60	13.20
70	50	3.85	27.61	5.52	11.04
	60	4.62	30.24	6.05	12.10
	70	5.39	32.67	6.53	13.07
	80	6.16	34.92	6.98	13.97
	90	6.93	37.04	7.41	14.82
	100	7.7	39.05	7.81	15.62
80	50	4.4	29.52	5.90	11.81
	60	5.28	32.33	6.47	12.93
	70	6.16	34.92	6.98	13.97
	80	7.04	37.34	7.47	14.93
	90	7.92	39.60	7.92	15.84
	100	8.8	41.74	8.35	16.70
90	50	4.95	31.31	6.26	12.52
	60	5.94	34.29	6.86	13.72
	70	6.93	37.04	7.41	14.82
	80	7.92	39.60	7.92	15.84
	90	8.91	42.00	8.40	16.80
	100	9.9	44.27	8.85	17.71
100	50	5.5	33.00	6.60	13.20
	60	6.6	36.15	7.23	14.46
	70	7.7	39.05	7.81	15.62
	80	8.8	41.74	8.35	16.70
	90	9.9	44.27	8.85	17.71
	100	11	46.67	9.33	18.67
110	50	6.05	34.61	6.92	13.84
	60	7.26	37.91	7.58	15.17
	70	8.47	40.95	8.19	16.38
	80	9.68	43.78	8.76	17.51
	90	10.89	46.44	9.29	18.57
	100	12.1	48.95	9.79	19.58

1½" PEX pipe expansion arm

PEX has a free-body thermal expansion rate of 1.1"/10°F ΔT/100 ft. (27.94mm/5.56°C ΔT/30.48m).

Delta T (ΔT)	Run (ft)	Delta L (in)	Flexible arm length (in)	L1 (in)	L2 (in)
120	50	6.6	36.15	7.23	14.46
	60	7.92	39.60	7.92	15.84
	70	9.24	42.77	8.55	17.11
	80	10.56	45.73	9.15	18.29
	90	11.88	48.50	9.70	19.40
	100	13.2	51.12	10.22	20.45
130	50	7.15	37.63	7.53	15.05
	60	8.58	41.22	8.24	16.49
	70	10.01	44.52	8.90	17.81
	80	11.44	47.59	9.52	19.04
	90	12.87	50.48	10.10	20.19
	100	14.3	53.21	10.64	21.28
140	50	7.7	39.05	7.81	15.62
	60	9.24	42.77	8.55	17.11
	70	10.78	46.20	9.24	18.48
	80	12.32	49.39	9.88	19.76
	90	13.86	52.39	10.48	20.95
	100	15.4	55.22	11.04	22.09
150	50	8.25	40.42	8.08	16.17
	60	9.9	44.27	8.85	17.71
	70	11.55	47.82	9.56	19.13
	80	13.2	51.12	10.22	20.45
	90	14.85	54.22	10.84	21.69
	100	16.5	57.16	11.43	22.86
160	50	8.8	41.74	8.35	16.70
	60	10.56	45.73	9.15	18.29
	70	12.32	49.39	9.88	19.76
	80	14.08	52.80	10.56	21.12
	90	15.84	56.00	11.20	22.40
	100	17.6	59.03	11.81	23.61

1½" PEX pipe expansion arm

PEX has a free-body thermal expansion rate of 1.1"/10°F ΔT/100 ft. (27.94mm/5.56°C ΔT/30.48m).

Delta T (ΔT)	Run (ft)	Delta L (in)	Flexible arm length (in)	L1 (in)	L2 (in)
10	50	0.55	11.34	2.27	4.54
	60	0.66	12.43	2.49	4.97
	70	0.77	13.42	2.68	5.37
	80	0.88	14.35	2.87	5.74
	90	0.99	15.22	3.04	6.09
	100	1.1	16.04	3.21	6.42

Table E-3: PEX pipe expansion arm calculations ½" to 3"

1½" PEX pipe expansion arm

PEX has a free-body thermal expansion rate of 1.1"/10°F ΔT/100 ft. (27.94mm/5.56°C ΔT/30.48m).

Delta T (ΔT)	Run (ft)	Delta L (in)	Flexible arm length (in)	L1 (in)	L2 (in)
20	50	1.1	16.04	3.21	6.42
	60	1.32	17.57	3.51	7.03
	70	1.54	18.98	3.80	7.59
	80	1.76	20.29	4.06	8.12
	90	1.98	21.52	4.30	8.61
	100	2.2	22.69	4.54	9.08
30	50	1.65	19.65	3.93	7.86
	60	1.98	21.52	4.30	8.61
	70	2.31	23.25	4.65	9.30
	80	2.64	24.85	4.97	9.94
	90	2.97	26.36	5.27	10.54
	100	3.3	27.79	5.56	11.12
40	50	2.2	22.69	4.54	9.08
	60	2.64	24.85	4.97	9.94
	70	3.08	26.85	5.37	10.74
	80	3.52	28.70	5.74	11.48
	90	3.96	30.44	6.09	12.18
	100	4.4	32.09	6.42	12.83
50	50	2.75	25.37	5.07	10.15
	60	3.3	27.79	5.56	11.12
	70	3.85	30.01	6.00	12.01
	80	4.4	32.09	6.42	12.83
	90	4.95	34.03	6.81	13.61
	100	5.5	35.87	7.17	14.35
60	50	3.3	27.79	5.56	11.12
	60	3.96	30.44	6.09	12.18
	70	4.62	32.88	6.58	13.15
	80	5.28	35.15	7.03	14.06
	90	5.94	37.28	7.46	14.91
	100	6.6	39.30	7.86	15.72
70	50	3.85	30.01	6.00	12.01
	60	4.62	32.88	6.58	13.15
	70	5.39	35.51	7.10	14.21
	80	6.16	37.97	7.59	15.19
	90	6.93	40.27	8.05	16.11
	100	7.7	42.45	8.49	16.98
80	50	4.4	32.09	6.42	12.83
	60	5.28	35.15	7.03	14.06
	70	6.16	37.97	7.59	15.19
	80	7.04	40.59	8.12	16.24
	90	7.92	43.05	8.61	17.22
	100	8.8	45.38	9.08	18.15

1½" PEX pipe expansion arm

PEX has a free-body thermal expansion rate of 1.1"/10°F ΔT/100 ft. (27.94mm/5.56°C ΔT/30.48m).

Delta T (ΔT)	Run (ft)	Delta L (in)	Flexible arm length (in)	L1 (in)	L2 (in)
90	50	4.95	34.03	6.81	13.61
	60	5.94	37.28	7.46	14.91
	70	6.93	40.27	8.05	16.11
	80	7.92	43.05	8.61	17.22
	90	8.91	45.66	9.13	18.26
	100	9.9	48.13	9.63	19.25
100	50	5.5	35.87	7.17	14.35
	60	6.6	39.30	7.86	15.72
	70	7.7	42.45	8.49	16.98
	80	8.8	45.38	9.08	18.15
	90	9.9	48.13	9.63	19.25
	100	11	50.73	10.15	20.29
110	50	6.05	37.63	7.53	15.05
	60	7.26	41.22	8.24	16.49
	70	8.47	44.52	8.90	17.81
	80	9.68	47.59	9.52	19.04
	90	10.89	50.48	10.10	20.19
	100	12.1	53.21	10.64	21.28
120	50	6.6	39.30	7.86	15.72
	60	7.92	43.05	8.61	17.22
	70	9.24	46.50	9.30	18.60
	80	10.56	49.71	9.94	19.88
	90	11.88	52.72	10.54	21.09
	100	13.2	55.58	11.12	22.23
130	50	7.15	40.90	8.18	16.36
	60	8.58	44.81	8.96	17.92
	70	10.01	48.40	9.68	19.36
	80	11.44	51.74	10.35	20.70
	90	12.87	54.88	10.98	21.95
	100	14.3	57.85	11.57	23.14
140	50	7.7	42.45	8.49	16.98
	60	9.24	46.50	9.30	18.60
	70	10.78	50.22	10.04	20.09
	80	12.32	53.69	10.74	21.48
	90	13.86	56.95	11.39	22.78
	100	15.4	60.03	12.01	24.01
150	50	8.25	43.94	8.79	17.57
	60	9.9	48.13	9.63	19.25
	70	11.55	51.99	10.40	20.79
	80	13.2	55.58	11.12	22.23
	90	14.85	58.95	11.79	23.58
	100	16.5	62.14	12.43	24.85

Table E-3: PEX pipe expansion arm calculations ½" to 3"

1½" PEX pipe expansion arm

Delta T (ΔT)	Run (ft)	Delta L (in)	Flexible arm length (in)	L1 (in)	L2 (in)
160	50	8.8	45.38	9.08	18.15
	60	10.56	49.71	9.94	19.88
	70	12.32	53.69	10.74	21.48
	80	14.08	57.40	11.48	22.96
	90	15.84	60.88	12.18	24.35
	100	17.6	64.17	12.83	25.67

2" PEX pipe expansion arm

Delta T (ΔT)	Run (ft)	Delta L (in)	Flexible arm length (in)	L1 (in)	L2 (in)
10	50	0.55	12.97	2.59	5.19
	60	0.66	14.21	2.84	5.68
	70	0.77	15.35	3.07	6.14
	80	0.88	16.41	3.28	6.56
	90	0.99	17.41	3.48	6.96
	100	1.1	18.35	3.67	7.34
20	50	1.1	18.35	3.67	7.34
	60	1.32	20.10	4.02	8.04
	70	1.54	21.71	4.34	8.68
	80	1.76	23.21	4.64	9.28
	90	1.98	24.61	4.92	9.85
	100	2.2	25.95	5.19	10.38
30	50	1.65	22.47	4.49	8.99
	60	1.98	24.61	4.92	9.85
	70	2.31	26.59	5.32	10.63
	80	2.64	28.42	5.68	11.37
	90	2.97	30.15	6.03	12.06
	100	3.3	31.78	6.36	12.71
40	50	2.2	25.95	5.19	10.38
	60	2.64	28.42	5.68	11.37
	70	3.08	30.70	6.14	12.28
	80	3.52	32.82	6.56	13.13
	90	3.96	34.81	6.96	13.92
	100	4.4	36.69	7.34	14.68
50	50	2.75	29.01	5.80	11.60
	60	3.3	31.78	6.36	12.71
	70	3.85	34.32	6.86	13.73
	80	4.4	36.69	7.34	14.68
	90	4.95	38.92	7.78	15.57
	100	5.5	41.02	8.20	16.41

2" PEX pipe expansion arm

Delta T (ΔT)	Run (ft)	Delta L (in)	Flexible arm length (in)	L1 (in)	L2 (in)
60	50	3.3	31.78	6.36	12.71
	60	3.96	34.81	6.96	13.92
	70	4.62	37.60	7.52	15.04
	80	5.28	40.20	8.04	16.08
	90	5.94	42.63	8.53	17.05
	100	6.6	44.94	8.99	17.98
70	50	3.85	34.32	6.86	13.73
	60	4.62	37.60	7.52	15.04
	70	5.39	40.61	8.12	16.24
	80	6.16	43.42	8.68	17.37
	90	6.93	46.05	9.21	18.42
	100	7.7	48.54	9.71	19.42
80	50	4.4	36.69	7.34	14.68
	60	5.28	40.20	8.04	16.08
	70	6.16	43.42	8.68	17.37
	80	7.04	46.41	9.28	18.57
	90	7.92	49.23	9.85	19.69
	100	8.8	51.89	10.38	20.76
90	50	4.95	38.92	7.78	15.57
	60	5.94	42.63	8.53	17.05
	70	6.93	46.05	9.21	18.42
	80	7.92	49.23	9.85	19.69
	90	8.91	52.22	10.44	20.89
	100	9.9	55.04	11.01	22.02
100	50	5.5	41.02	8.20	16.41
	60	6.6	44.94	8.99	17.98
	70	7.7	48.54	9.71	19.42
	80	8.8	51.89	10.38	20.76
	90	9.9	55.04	11.01	22.02
	100	11	58.02	11.60	23.21
110	50	6.05	43.03	8.61	17.21
	60	7.26	47.13	9.43	18.85
	70	8.47	50.91	10.18	20.36
	80	9.68	54.42	10.88	21.77
	90	10.89	57.73	11.55	23.09
	100	12.1	60.85	12.17	24.34
120	50	6.6	44.94	8.99	17.98
	60	7.92	49.23	9.85	19.69
	70	9.24	53.17	10.63	21.27
	80	10.56	56.85	11.37	22.74
	90	11.88	60.29	12.06	24.12
	100	13.2	63.55	12.71	25.42

PEX has a free-body thermal expansion rate of 1.1"/10°F ΔT/100 ft. (27.94mm/5.56°C ΔT/30.48m).

Table E-3: PEX pipe expansion arm calculations ½" to 3"

2" PEX pipe expansion arm

PEX has a free-body thermal expansion rate of 1.1"/10°F ΔT/100 ft. (27.94mm/5.56°C ΔT/30.48m).	Delta T (ΔT)	Run (ft)	Delta L (in)	Flexible arm length (in)	L1 (in)	L2 (in)	
	130	50	50	7.15	46.77	9.35	18.71
		60	60	8.58	51.24	10.25	20.50
		70	70	10.01	55.34	11.07	22.14
		80	80	11.44	59.17	11.83	23.67
		90	90	12.87	62.76	12.55	25.10
	140	50	50	7.7	48.54	9.71	19.42
		60	60	9.24	53.17	10.63	21.27
		70	70	10.78	57.43	11.49	22.97
		80	80	12.32	61.40	12.28	24.56
90		90	13.86	65.12	13.02	26.05	
150	50	50	8.25	50.24	10.05	20.10	
	60	60	9.9	55.04	11.01	22.02	
	70	70	11.55	59.45	11.89	23.78	
	80	80	13.2	63.55	12.71	25.42	
	90	90	14.85	67.41	13.48	26.96	
160	50	50	8.8	51.89	10.38	20.76	
	60	60	10.56	56.85	11.37	22.74	
	70	70	12.32	61.40	12.28	24.56	
	80	80	14.08	65.64	13.13	26.26	
	90	90	15.84	69.62	13.92	27.85	
100	100	17.6	73.39	14.68	29.35		

Table E-3: PEX pipe expansion arm calculations ½" to 3"

2½" PEX pipe expansion arm

PEX has a free-body thermal expansion rate of 1.1"/10°F ΔT/100 ft. (27.94mm/5.56°C ΔT/30.48m).	Delta T (ΔT)	Run (ft)	Delta L (in)	Flexible arm length (in)	L1 (in)	L2 (in)	
	10	50	50	0.55	14.42	2.88	5.77
		60	60	0.66	15.79	3.16	6.32
		70	70	0.77	17.06	3.41	6.82
		80	80	0.88	18.24	3.65	7.30
		90	90	0.99	19.34	3.87	7.74
		100	100	1.1	20.39	4.08	8.16
	20	50	50	1.1	20.39	4.08	8.16
		60	60	1.32	22.34	4.47	8.93
		70	70	1.54	24.13	4.83	9.65
80		80	1.76	25.79	5.16	10.32	
90		90	1.98	27.36	5.47	10.94	
100		100	2.2	28.84	5.77	11.53	

Table E-3: PEX pipe expansion arm calculations ½" to 3"

2½" PEX pipe expansion arm

PEX has a free-body thermal expansion rate of 1.1"/10°F ΔT/100 ft. (27.94mm/5.56°C ΔT/30.48m).	Delta T (ΔT)	Run (ft)	Delta L (in)	Flexible arm length (in)	L1 (in)	L2 (in)	
	30	50	50	1.65	24.97	4.99	9.99
		60	60	1.98	27.36	5.47	10.94
		70	70	2.31	29.55	5.91	11.82
		80	80	2.64	31.59	6.32	12.64
		90	90	2.97	33.51	6.70	13.40
	40	50	50	2.2	28.84	5.77	11.53
		60	60	2.64	31.59	6.32	12.64
		70	70	3.08	34.12	6.82	13.65
		80	80	3.52	36.48	7.30	14.59
90		90	3.96	38.69	7.74	15.48	
50	50	50	2.75	32.24	6.45	12.90	
	60	60	3.3	35.32	7.06	14.13	
	70	70	3.85	38.15	7.63	15.26	
	80	80	4.4	40.78	8.16	16.31	
	90	90	4.95	43.26	8.65	17.30	
60	50	50	3.3	35.32	7.06	14.13	
	60	60	3.96	38.69	7.74	15.48	
	70	70	4.62	41.79	8.36	16.72	
	80	80	5.28	44.67	8.93	17.87	
	90	90	5.94	47.38	9.48	18.95	
70	50	50	3.85	38.15	7.63	15.26	
	60	60	4.62	41.79	8.36	16.72	
	70	70	5.39	45.14	9.03	18.06	
	80	80	6.16	48.25	9.65	19.30	
	90	90	6.93	51.18	10.24	20.47	
80	50	50	4.4	40.78	8.16	16.31	
	60	60	5.28	44.67	8.93	17.87	
	70	70	6.16	48.25	9.65	19.30	
	80	80	7.04	51.59	10.32	20.63	
	90	90	7.92	54.72	10.94	21.89	
90	50	50	4.95	43.26	8.65	17.30	
	60	60	5.94	47.38	9.48	18.95	
	70	70	6.93	51.18	10.24	20.47	
	80	80	7.92	54.72	10.94	21.89	
	90	90	8.91	58.03	11.61	23.21	
100	100	9.9	61.17	12.23	24.47		

Table E-3: PEX pipe expansion arm calculations ½" to 3"

2½" PEX pipe expansion arm

PEX has a free-body thermal expansion rate of 1.1"/10°F ΔT/100 ft. (27.94mm/5.56°C ΔT/30.48m).	Delta T (ΔT)	Run (ft)	Delta L (in)	Flexible arm length (in)	L1 (in)	L2 (in)	
	100	50	50	5.5	45.60	9.12	18.24
		60	60	6.6	49.95	9.99	19.98
		70	70	7.7	53.95	10.79	21.58
		80	80	8.8	57.67	11.53	23.07
		90	90	9.9	61.17	12.23	24.47
	100	100	11	64.48	12.90	25.79	
	110	50	50	6.05	47.82	9.56	19.13
		60	60	7.26	52.39	10.48	20.95
		70	70	8.47	56.58	11.32	22.63
80		80	9.68	60.49	12.10	24.20	
90		90	10.89	64.16	12.83	25.66	
100	100	12.1	67.63	13.53	27.05		
120	50	50	6.6	49.95	9.99	19.98	
	60	60	7.92	54.72	10.94	21.89	
	70	70	9.24	59.10	11.82	23.64	
	80	80	10.56	63.18	12.64	25.27	
	90	90	11.88	67.01	13.40	26.80	
100	100	13.2	70.64	14.13	28.25		
130	50	50	7.15	51.99	10.40	20.79	
	60	60	8.58	56.95	11.39	22.78	
	70	70	10.01	61.51	12.30	24.60	
	80	80	11.44	65.76	13.15	26.30	
	90	90	12.87	69.75	13.95	27.90	
100	100	14.3	73.52	14.70	29.41		
140	50	50	7.7	53.95	10.79	21.58	
	60	60	9.24	59.10	11.82	23.64	
	70	70	10.78	63.83	12.77	25.53	
	80	80	12.32	68.24	13.65	27.30	
	90	90	13.86	72.38	14.48	28.95	
100	100	15.4	76.30	15.26	30.52		
150	50	50	8.25	55.84	11.17	22.34	
	60	60	9.9	61.17	12.23	24.47	
	70	70	11.55	66.07	13.21	26.43	
	80	80	13.2	70.64	14.13	28.25	
	90	90	14.85	74.92	14.98	29.97	
100	100	16.5	78.97	15.79	31.59		
160	50	50	8.8	57.67	11.53	23.07	
	60	60	10.56	63.18	12.64	25.27	
	70	70	12.32	68.24	13.65	27.30	
	80	80	14.08	72.95	14.59	29.18	
	90	90	15.84	77.38	15.48	30.95	
100	100	17.6	81.56	16.31	32.63		

3" PEX pipe expansion arm

PEX has a free-body thermal expansion rate of 1.1"/10°F ΔT/100 ft. (27.94mm/5.56°C ΔT/30.48m).	Delta T (ΔT)	Run (ft)	Delta L (in)	Flexible arm length (in)	L1 (in)	L2 (in)	
	10	50	50	0.55	15.73	3.15	6.29
		60	60	0.66	17.23	3.45	6.89
		70	70	0.77	18.61	3.72	7.45
		80	80	0.88	19.90	3.98	7.96
		90	90	0.99	21.11	4.22	8.44
	100	100	1.1	22.25	4.45	8.90	
	20	50	50	1.1	22.25	4.45	8.90
		60	60	1.32	24.37	4.87	9.75
		70	70	1.54	26.32	5.26	10.53
80		80	1.76	28.14	5.63	11.26	
90		90	1.98	29.85	5.97	11.94	
100	100	2.2	31.46	6.29	12.59		
30	50	50	1.65	27.25	5.45	10.90	
	60	60	1.98	29.85	5.97	11.94	
	70	70	2.31	32.24	6.45	12.90	
	80	80	2.64	34.47	6.89	13.79	
	90	90	2.97	36.56	7.31	14.62	
100	100	3.3	38.54	7.71	15.41		
40	50	50	2.2	31.46	6.29	12.59	
	60	60	2.64	34.47	6.89	13.79	
	70	70	3.08	37.23	7.45	14.89	
	80	80	3.52	39.80	7.96	15.92	
	90	90	3.96	42.21	8.44	16.89	
100	100	4.4	44.50	8.90	17.80		
50	50	50	2.75	35.18	7.04	14.07	
	60	60	3.3	38.54	7.71	15.41	
	70	70	3.85	41.62	8.32	16.65	
	80	80	4.4	44.50	8.90	17.80	
	90	90	4.95	47.20	9.44	18.88	
100	100	5.5	49.75	9.95	19.90		
60	50	50	3.3	38.54	7.71	15.41	
	60	60	3.96	42.21	8.44	16.89	
	70	70	4.62	45.60	9.12	18.24	
	80	80	5.28	48.74	9.75	19.50	
	90	90	5.94	51.70	10.34	20.68	
100	100	6.6	54.50	10.90	21.80		
70	50	50	3.85	41.62	8.32	16.65	
	60	60	4.62	45.60	9.12	18.24	
	70	70	5.39	49.25	9.85	19.70	
	80	80	6.16	52.65	10.53	21.06	
	90	90	6.93	55.84	11.17	22.34	
100	100	7.7	58.86	11.77	23.55		

Table E-3: PEX pipe expansion arm calculations ½" to 3"

3" PEX pipe expansion arm

PEX has a free-body thermal expansion rate of 1.1"/10°F ΔT/100 ft. (27.94mm/5.56°C ΔT/30.48m).

Delta T (ΔT)	Run (ft)	Delta L (in)	Flexible arm length (in)	L1 (in)	L2 (in)
80	50	4.4	44.50	8.90	17.80
	60	5.28	48.74	9.75	19.50
	70	6.16	52.65	10.53	21.06
	80	7.04	56.28	11.26	22.51
	90	7.92	59.70	11.94	23.88
	100	8.8	62.93	12.59	25.17
90	50	4.95	47.20	9.44	18.88
	60	5.94	51.70	10.34	20.68
	70	6.93	55.84	11.17	22.34
	80	7.92	59.70	11.94	23.88
	90	8.91	63.32	12.66	25.33
	100	9.9	66.75	13.35	26.70
100	50	5.5	49.75	9.95	19.90
	60	6.6	54.50	10.90	21.80
	70	7.7	58.86	11.77	23.55
	80	8.8	62.93	12.59	25.17
	90	9.9	66.75	13.35	26.70
	100	11	70.36	14.07	28.14
110	50	6.05	52.18	10.44	20.87
	60	7.26	57.16	11.43	22.86
	70	8.47	61.74	12.35	24.69
	80	9.68	66.00	13.20	26.40
	90	10.89	70.00	14.00	28.00
	100	12.1	73.79	14.76	29.52
120	50	6.6	54.50	10.90	21.80
	60	7.92	59.70	11.94	23.88
	70	9.24	64.48	12.90	25.79
	80	10.56	68.93	13.79	27.57
	90	11.88	73.12	14.62	29.25
	100	13.2	77.07	15.41	30.83
130	50	7.15	56.72	11.34	22.69
	60	8.58	62.14	12.43	24.85
	70	10.01	67.12	13.42	26.85
	80	11.44	71.75	14.35	28.70
	90	12.87	76.10	15.22	30.44
	100	14.3	80.22	16.04	32.09
140	50	7.7	58.86	11.77	23.55
	60	9.24	64.48	12.90	25.79
	70	10.78	69.65	13.93	27.86
	80	12.32	74.46	14.89	29.78
	90	13.86	78.97	15.79	31.59
	100	15.4	83.25	16.65	33.30

3" PEX pipe expansion arm

Delta T (ΔT)	Run (ft)	Delta L (in)	Flexible arm length (in)	L1 (in)	L2 (in)
150	50	8.25	60.93	12.19	24.37
	60	9.9	66.75	13.35	26.70
	70	11.55	72.09	14.42	28.84
	80	13.2	77.07	15.41	30.83
	90	14.85	81.75	16.35	32.70
	100	16.5	86.17	17.23	34.47
160	50	8.8	62.93	12.59	25.17
	60	10.56	68.93	13.79	27.57
	70	12.32	74.46	14.89	29.78
	80	14.08	79.60	15.92	31.84
	90	15.84	84.43	16.89	33.77
	100	17.6	88.99	17.80	35.60

Table E-3: PEX pipe expansion arm calculations ½" to 3"

Appendix F:

Pipe heat loss and surface temperature

½" Uponor PEX heat loss at 50°F/10°C ambient

Water temp (°F)	Heat loss (btu/hr-ft)				
	No insulation	½" insulation	1" insulation	1½" insulation	2" insulation
30	-3.2	-2.0	-1.6	-1.4	-1.2
40	-1.6	-1.0	-0.8	-0.7	-0.6
50	0.0	0.0	0.0	0.0	0.0
60	1.6	1.0	0.8	0.7	0.6
70	3.2	2.0	1.6	1.4	1.2
80	4.7	3.0	2.4	2.0	1.8
90	6.3	4.1	3.2	2.7	2.4
100	7.9	5.1	4.0	3.4	3.1
110	9.5	6.1	4.7	4.1	3.7
120	11.1	7.1	5.5	4.8	4.3
130	12.6	8.1	6.3	5.4	4.9
140	14.2	9.1	7.1	6.1	5.5
150	15.8	10.1	7.9	6.8	6.1
160	17.4	11.1	8.7	7.5	6.7
170	18.9	12.2	9.5	8.2	7.3
180	20.5	13.2	10.3	8.8	8.0
190	22.1	14.2	11.1	9.5	8.6
200	23.7	15.2	11.9	10.2	9.2

½" Uponor PEX surface temperature at 50°F/10°C ambient

Water temp (°F)	Surface temperature (°F)				
	No insulation	½" insulation	1" insulation	1½" insulation	2" insulation
30	30.7	45.2	47.7	48.6	49.0
40	40.4	47.6	48.8	49.3	49.5
50	50.0	50.0	50.0	50.0	50.0
60	59.6	52.4	51.2	50.7	50.5
70	69.3	54.8	52.3	51.4	51.0
80	78.9	57.1	53.5	52.1	51.5
90	88.6	59.5	54.6	52.9	52.0
100	98.2	61.9	55.8	53.6	52.5
110	107.9	64.3	56.9	54.3	53.0
120	117.5	66.7	58.1	55.0	53.5
130	127.2	69.0	59.2	55.7	54.0
140	136.8	71.4	60.4	56.4	54.5
150	146.5	73.8	61.5	57.2	55.1
160	156.1	76.2	62.7	57.9	55.6
170	165.8	78.6	63.8	58.6	56.1
180	175.4	81.0	65.0	59.3	56.6
190	185.1	83.3	66.1	60.0	57.1
200	194.7	85.7	67.3	60.7	57.6

1. All calculations based on cylindrical thermal resistance methodology (ASHRAE).
2. Based on fluid velocity of 8 ft./sec. at 160°F/71.1°C (maximizing heat transfer from 100% water).
3. Pipe convection set to be 1.00 Btu/hr·ft²·°F (based on standard value for free convection of air).
4. This heat loss comparison uses 0.25 Btu·in/(hr·ft²·°F) as the insulation thermal conductivity.
This is a standard value for fiberglass pipe insulation at a 100°F/37.8°C mean temperature.

Pipe heat loss and surface temperature

¾" Uponor PEX heat loss at 50°F/10°C ambient

Water temp (°F)	Heat loss (btu/hr-ft)				
	No insulation	½" insulation	1" insulation	1½" insulation	2" insulation
30	-4.4	-2.5	-1.9	-1.6	-1.4
40	-2.2	-1.2	-0.9	-0.8	-0.7
50	0.0	0.0	0.0	0.0	0.0
60	2.2	1.2	0.9	0.8	0.7
70	4.4	2.5	1.9	1.6	1.4
80	6.6	3.7	2.8	2.4	2.1
90	8.7	5.0	3.8	3.2	2.8
100	10.9	6.2	4.7	4.0	3.5
110	13.1	7.4	5.6	4.8	4.3
120	15.3	8.7	6.6	5.6	5.0
130	17.5	9.9	7.5	6.4	5.7
140	19.7	11.2	8.5	7.2	6.4
150	21.9	12.4	9.4	8.0	7.1
160	24.0	13.6	10.4	8.8	7.8
170	26.2	14.9	11.3	9.6	8.5
180	28.4	16.1	12.2	10.3	9.2
190	30.6	17.4	13.2	11.1	9.9
200	32.8	18.6	14.1	11.9	10.6

¾" Uponor PEX surface temperature at 50°F/10°C ambient

Water temp (°F)	Surface temperature (°F)				
	No insulation	½" insulation	1" insulation	1½" insulation	2" insulation
30	30.9	45.0	47.5	48.4	48.9
40	40.5	47.5	48.7	49.2	49.4
50	50.0	50.0	50.0	50.0	50.0
60	59.5	52.5	51.3	50.8	50.6
70	69.1	55.0	52.5	51.6	51.1
80	78.6	57.6	53.8	52.4	51.7
90	88.2	60.1	55.0	53.1	52.2
100	97.7	62.6	56.3	53.9	52.8
110	107.3	65.1	57.5	54.7	53.3
120	116.8	67.7	58.8	55.5	53.9
130	126.3	70.2	60.0	56.3	54.4
140	135.9	72.7	61.3	57.1	55.0
150	145.4	75.2	62.5	57.8	55.6
160	155.0	77.8	63.8	58.6	56.1
170	164.5	80.3	65.0	59.4	56.7
180	174.1	82.8	66.3	60.2	57.2
190	183.6	85.3	67.5	61.0	57.8
200	193.1	87.9	68.8	61.8	58.3

1. All calculations based on cylindrical thermal resistance methodology (ASHRAE).
2. Based on fluid velocity of 8 ft./sec. at 160°F/71.1°C (maximizing heat transfer from 100% water).
3. Pipe convection set to be 1.00 Btu/hr•ft²•°F (based on standard value for free convection of air).
4. This heat loss comparison uses 0.25 Btu•in/(hr•ft²•°F) as the insulation thermal conductivity.
This is a standard value for fiberglass pipe insulation at a 100°F/37.8°C mean temperature.

Pipe heat loss and surface temperature

1" Uponor PEX heat loss at 50°F/10°C ambient

Water temp (°F)	Heat loss (btu/hr-ft)				
	No insulation	½" insulation	1" insulation	1½" insulation	2" insulation
30	-5.5	-2.9	-2.2	-1.8	-1.6
40	-2.8	-1.5	-1.1	-0.9	-0.8
50	0.0	0.0	0.0	0.0	0.0
60	2.8	1.5	1.1	0.9	0.8
70	5.5	2.9	2.2	1.8	1.6
80	8.3	4.4	3.2	2.7	2.4
90	11.1	5.8	4.3	3.6	3.2
100	13.9	7.3	5.4	4.5	4.0
110	16.6	8.7	6.5	5.4	4.8
120	19.4	10.2	7.6	6.3	5.6
130	22.2	11.7	8.7	7.2	6.4
140	25.0	13.1	9.7	8.1	7.2
150	27.7	14.6	10.8	9.0	8.0
160	30.5	16.0	11.9	9.9	8.8
170	33.3	17.5	13.0	10.8	9.6
180	36.1	18.9	14.1	11.8	10.4
190	38.8	20.4	15.2	12.7	11.2
200	41.6	21.8	16.2	13.6	12.0

1" Uponor PEX surface temperature at 50°F/10°C ambient

Water temp (°F)	Surface temperature (°F)				
	No insulation	½" insulation	1" insulation	1½" insulation	2" insulation
30	31.2	44.8	47.4	48.3	48.8
40	40.6	47.4	48.7	49.2	49.4
50	50.0	50.0	50.0	50.0	50.0
60	59.4	52.6	51.3	50.8	50.6
70	68.8	55.2	52.6	51.7	51.2
80	78.3	57.9	54.0	52.5	51.8
90	87.7	60.5	55.3	53.3	52.4
100	97.1	63.1	56.6	54.2	53.0
110	106.5	65.7	57.9	55.0	53.6
120	115.9	68.3	59.3	55.9	54.2
130	125.3	70.9	60.6	56.7	54.8
140	134.8	73.6	61.9	57.5	55.3
150	144.2	76.2	63.2	58.4	55.9
160	153.6	78.8	64.6	59.2	56.5
170	163.0	81.4	65.9	60.0	57.1
180	172.4	84.0	67.2	60.9	57.7
190	181.9	86.7	68.5	61.7	58.3
200	191.3	89.3	69.8	62.6	58.9

1. All calculations based on cylindrical thermal resistance methodology (ASHRAE).
2. Based on fluid velocity of 8 ft./sec. at 160°F/71.1°C (maximizing heat transfer from 100% water).
3. Pipe convection set to be 1.00 Btu/hr•ft²•°F (based on standard value for free convection of air).
4. This heat loss comparison uses 0.25 Btu•in/(hr•ft²•°F) as the insulation thermal conductivity.
This is a standard value for fiberglass pipe insulation at a 100°F/37.8°C mean temperature.

Pipe heat loss and surface temperature

1¼" Uponor PEX heat loss at 50°F/10°C ambient

Water temp (°F)	Heat loss (btu/hr-ft)				
	No insulation	½" insulation	1" insulation	1½" insulation	2" insulation
30	-6.7	-3.3	-2.4	-2.0	-1.8
40	-3.3	-1.7	-1.2	-1.0	-0.9
50	0.0	0.0	0.0	0.0	0.0
60	3.3	1.7	1.2	1.0	0.9
70	6.7	3.3	2.4	2.0	1.8
80	10.0	5.0	3.7	3.0	2.6
90	13.4	6.7	4.9	4.0	3.5
100	16.7	8.3	6.1	5.0	4.4
110	20.1	10.0	7.3	6.0	5.3
120	23.4	11.7	8.5	7.1	6.2
130	26.8	13.3	9.8	8.1	7.1
140	30.1	15.0	11.0	9.1	7.9
150	33.5	16.7	12.2	10.1	8.8
160	36.8	18.4	13.4	11.1	9.7
170	40.2	20.0	14.6	12.1	10.6
180	43.5	21.7	15.9	13.1	11.5
190	46.9	23.4	17.1	14.1	12.4
200	50.2	25.0	18.3	15.1	13.2

1¼" Uponor PEX surface temperature at 50°F/10°C ambient

Water temp (°F)	Surface temperature (°F)				
	No insulation	½" insulation	1" insulation	1½" insulation	2" insulation
30	31.4	44.6	47.2	48.2	48.7
40	40.7	47.3	48.6	49.1	49.4
50	50.0	50.0	50.0	50.0	50.0
60	59.3	52.7	51.4	50.9	50.6
70	68.6	55.4	52.8	51.8	51.3
80	77.9	58.1	54.1	52.6	51.9
90	87.2	60.7	55.5	53.5	52.5
100	96.5	63.4	56.9	54.4	53.1
110	105.8	66.1	58.3	55.3	53.8
120	115.1	68.8	59.7	56.2	54.4
130	124.4	71.5	61.0	57.0	55.0
140	133.7	74.2	62.4	57.9	55.6
150	143.0	76.8	63.8	58.8	56.3
160	152.3	79.5	65.2	59.7	56.9
170	161.6	82.2	66.6	60.6	57.5
180	170.9	84.9	67.9	61.4	58.2
190	180.2	87.6	69.3	62.3	58.8
200	189.5	90.3	70.7	63.2	59.4

1. All calculations based on cylindrical thermal resistance methodology (ASHRAE).
2. Based on fluid velocity of 8 ft./sec. at 160°F/71.1°C (maximizing heat transfer from 100% water).
3. Pipe convection set to be 1.00 Btu/hr•ft²•°F (based on standard value for free convection of air).
4. This heat loss comparison uses 0.25 Btu•in/(hr•ft²•°F) as the insulation thermal conductivity. This is a standard value for fiberglass pipe insulation at a 100°F/37.8°C mean temperature.

Pipe heat loss and surface temperature

1½" Uponor PEX heat loss at 50°F/10°C ambient

Water temp (°F)	Heat loss (btu/hr-ft)				
	No insulation	½" insulation	1" insulation	1½" insulation	2" insulation
30	-7.8	-3.8	-2.7	-2.2	-1.9
40	-3.9	-1.9	-1.4	-1.1	-1.0
50	0.0	0.0	0.0	0.0	0.0
60	3.9	1.9	1.4	1.1	1.0
70	7.8	3.8	2.7	2.2	1.9
80	11.7	5.6	4.1	3.3	2.9
90	15.6	7.5	5.4	4.4	3.9
100	19.5	9.4	6.8	5.5	4.8
110	23.4	11.3	8.1	6.6	5.8
120	27.3	13.1	9.5	7.8	6.7
130	31.2	15.0	10.8	8.9	7.7
140	35.1	16.9	12.2	10.0	8.7
150	39.0	18.8	13.5	11.1	9.6
160	43.0	20.6	14.9	12.2	10.6
170	46.9	22.5	16.2	13.3	11.6
180	50.8	24.4	17.6	14.4	12.5
190	54.7	26.3	18.9	15.5	13.5
200	58.6	28.1	20.3	16.6	14.5

1½" Uponor PEX surface temperature at 50°F/10°C ambient

Water temp (°F)	Surface temperature (°F)				
	No insulation	½" insulation	1" insulation	1½" insulation	2" insulation
30	31.6	44.5	47.1	48.2	48.7
40	40.8	47.3	48.6	49.1	49.3
50	50.0	50.0	50.0	50.0	50.0
60	59.2	52.7	51.4	50.9	50.7
70	68.4	55.5	52.9	51.8	51.3
80	77.5	58.2	54.3	52.7	52.0
90	86.7	60.9	55.7	53.7	52.6
100	95.9	63.7	57.1	54.6	53.3
110	105.1	66.4	58.6	55.5	53.9
120	114.2	69.1	60.0	56.4	54.6
130	123.4	71.8	61.4	57.3	55.2
140	132.6	74.6	62.8	58.2	55.9
150	141.8	77.3	64.3	59.1	56.5
160	151.0	80.0	65.7	60.1	57.2
170	160.1	82.8	67.1	61.0	57.9
180	169.3	85.5	68.5	61.9	58.5
190	178.5	88.2	70.0	62.8	59.2
200	187.7	91.0	71.4	63.7	59.8

1. All calculations based on cylindrical thermal resistance methodology (ASHRAE).
2. Based on fluid velocity of 8 ft./sec. at 160°F/71.1°C (maximizing heat transfer from 100% water).
3. Pipe convection set to be 1.00 Btu/hr•ft²•°F (based on standard value for free convection of air).
4. This heat loss comparison uses 0.25 Btu•in/(hr•ft²•°F) as the insulation thermal conductivity.
This is a standard value for fiberglass pipe insulation at a 100°F/37.8°C mean temperature.

Pipe heat loss and surface temperature

2" Uponor PEX heat loss at 50°F/10°C ambient

Water temp (°F)	Heat loss (btu/hr-ft)				
	No insulation	½" insulation	1" insulation	1½" insulation	2" insulation
30	-10.0	-4.6	-3.2	-2.6	-2.2
40	-5.0	-2.3	-1.6	-1.3	-1.1
50	0.0	0.0	0.0	0.0	0.0
60	5.0	2.3	1.6	1.3	1.1
70	10.0	4.6	3.2	2.6	2.2
80	14.9	6.9	4.8	3.9	3.4
90	19.9	9.1	6.4	5.2	4.5
100	24.9	11.4	8.1	6.5	5.6
110	29.9	13.7	9.7	7.8	6.7
120	34.9	16.0	11.3	9.1	7.8
130	39.9	18.3	12.9	10.4	9.0
140	44.8	20.6	14.5	11.7	10.1
150	49.8	22.8	16.1	13.0	11.2
160	54.8	25.1	17.7	14.3	12.3
170	59.8	27.4	19.3	15.6	13.5
180	64.8	29.7	21.0	16.9	14.6
190	69.8	32.0	22.6	18.2	15.7
200	74.7	34.3	24.2	19.5	16.8

2" Uponor PEX surface temperature at 50°F/10°C ambient

Water temp (°F)	Surface temperature (°F)				
	No insulation	½" insulation	1" insulation	1½" insulation	2" insulation
30	32.1	44.4	47.0	48.1	48.6
40	41.0	47.2	48.5	49.0	49.3
50	50.0	50.0	50.0	50.0	50.0
60	59.0	52.8	51.5	51.0	50.7
70	67.9	55.6	53.0	51.9	51.4
80	76.9	58.4	54.5	52.9	52.1
90	85.8	61.2	56.0	53.9	52.8
100	94.8	64.0	57.5	54.9	53.5
110	103.7	66.8	59.0	55.8	54.2
120	112.7	69.5	60.5	56.8	54.9
130	121.7	72.3	61.9	57.8	55.6
140	130.6	75.1	63.4	58.7	56.3
150	139.6	77.9	64.9	59.7	57.0
160	148.5	80.7	66.4	60.7	57.7
170	157.5	83.5	67.9	61.6	58.4
180	166.4	86.3	69.4	62.6	59.1
190	175.4	89.1	70.9	63.6	59.8
200	184.3	91.9	72.4	64.6	60.5

1. All calculations based on cylindrical thermal resistance methodology (ASHRAE).
2. Based on fluid velocity of 8 ft./sec. at 160°F/71.1°C (maximizing heat transfer from 100% water).
3. Pipe convection set to be 1.00 Btu/hr•ft²•°F (based on standard value for free convection of air).
4. This heat loss comparison uses 0.25 Btu•in/(hr•ft²•°F) as the insulation thermal conductivity.
This is a standard value for fiberglass pipe insulation at a 100°F/37.8°C mean temperature.

Pipe heat loss and surface temperature

2½" Uponor PEX heat loss at 50°F/10°C Ambient

Water temp (°F)	Heat loss (btu/hr-ft)				
	No insulation	½" insulation	1" insulation	1½" insulation	2" insulation
30	-12.0	-5.4	-3.7	-3.0	-2.5
40	-6.0	-2.7	-1.9	-1.5	-1.3
50	0.0	0.0	0.0	0.0	0.0
60	6.0	2.7	1.9	1.5	1.3
70	12.0	5.4	3.7	3.0	2.5
80	18.0	8.0	5.6	4.5	3.8
90	24.0	10.7	7.5	6.0	5.1
100	30.0	13.4	9.3	7.5	6.4
110	36.0	16.1	11.2	8.9	7.6
120	42.0	18.8	13.1	10.4	8.9
130	48.0	21.5	14.9	11.9	10.2
140	54.1	24.1	16.8	13.4	11.5
150	60.1	26.8	18.6	14.9	12.7
160	66.1	29.5	20.5	16.4	14.0
170	72.1	32.2	22.4	17.9	15.3
180	78.1	34.9	24.2	19.4	16.5
190	84.1	37.5	26.1	20.9	17.8
200	90.1	40.2	28.0	22.4	19.1

2½" Uponor PEX surface temperature at 50°F/10°C ambient

Water temp (°F)	Surface temperature (°F)				
	No insulation	½" insulation	1" insulation	1½" insulation	2" insulation
30	32.5	44.3	46.9	48.0	48.5
40	41.3	47.2	48.5	49.0	49.3
50	50.0	50.0	50.0	50.0	50.0
60	58.7	52.8	51.5	51.0	50.7
70	67.5	55.7	53.1	52.0	51.5
80	76.2	58.5	54.6	53.0	52.2
90	85.0	61.3	56.2	54.0	52.9
100	93.7	64.1	57.7	55.1	53.7
110	102.4	67.0	59.2	56.1	54.4
120	111.2	69.8	60.8	57.1	55.1
130	119.9	72.6	62.3	58.1	55.9
140	128.7	75.4	63.9	59.1	56.6
150	137.4	78.3	65.4	60.1	57.3
160	146.1	81.1	66.9	61.1	58.1
170	154.9	83.9	68.5	62.1	58.8
180	163.6	86.7	70.0	63.2	59.5
190	172.3	89.6	71.6	64.2	60.3
200	181.1	92.4	73.1	65.2	61.0

1. All calculations based on cylindrical thermal resistance methodology (ASHRAE).
2. Based on fluid velocity of 8 ft./sec. at 160°F/71.1°C (maximizing heat transfer from 100% water).
3. Pipe convection set to be 1.00 Btu/hr•ft²•°F (based on standard value for free convection of air).
4. This heat loss comparison uses 0.25 Btu•in/(hr•ft²•°F) as the insulation thermal conductivity.
This is a standard value for fiberglass pipe insulation at a 100°F/37.8°C mean temperature.

Pipe heat loss and surface temperature

3" Uponor PEX heat loss at 50°F/10°C ambient

Water temp (°F)	Heat loss (btu/hr-ft)				
	No insulation	½" insulation	1" insulation	1½" insulation	2" insulation
30	-14.0	-6.1	-4.2	-3.3	-2.8
40	-7.0	-3.1	-2.1	-1.7	-1.4
50	0.0	0.0	0.0	0.0	0.0
60	7.0	3.1	2.1	1.7	1.4
70	14.0	6.1	4.2	3.3	2.8
80	21.0	9.2	6.3	5.0	4.3
90	28.0	12.3	8.5	6.7	5.7
100	34.9	15.4	10.6	8.4	7.1
110	41.9	18.4	12.7	10.0	8.5
120	48.9	21.5	14.8	11.7	9.9
130	55.9	24.6	16.9	13.4	11.4
140	62.9	27.6	19.0	15.1	12.8
150	69.9	30.7	21.1	16.7	14.2
160	76.9	33.8	23.2	18.4	15.6
170	83.9	36.9	25.4	20.1	17.0
180	90.8	39.9	27.5	21.8	18.5
190	97.8	43.0	29.6	23.4	19.9
200	104.8	46.1	31.7	25.1	21.3

3" Uponor PEX surface temperature at 50°F/10°C ambient

Water temp (°F)	Surface temperature (°F)				
	No insulation	½" insulation	1" insulation	1½" insulation	2" insulation
30	32.9	44.3	46.9	47.9	48.5
40	41.5	47.2	48.4	49.0	49.2
50	50.0	50.0	50.0	50.0	50.0
60	58.5	52.8	51.6	51.0	50.8
70	67.1	55.7	53.1	52.1	51.5
80	75.6	58.5	54.7	53.1	52.3
90	84.2	61.4	56.3	54.2	53.0
100	92.7	64.2	57.9	55.2	53.8
110	101.3	67.1	59.4	56.3	54.6
120	109.8	69.9	61.0	57.3	55.3
130	118.3	72.8	62.6	58.4	56.1
140	126.9	75.6	64.2	59.4	56.9
150	135.4	78.4	65.7	60.4	57.6
160	144.0	81.3	67.3	61.5	58.4
170	152.5	84.1	68.9	62.5	59.1
180	161.0	87.0	70.5	63.6	59.9
190	169.6	89.8	72.0	64.6	60.7
200	178.1	92.7	73.6	65.7	61.4

1. All calculations based on cylindrical thermal resistance methodology (ASHRAE).
2. Based on fluid velocity of 8 ft./sec. at 160°F/71.1°C (maximizing heat transfer from 100% water).
3. Pipe convection set to be 1.00 Btu/hr•ft²•°F (based on standard value for free convection of air).
4. This heat loss comparison uses 0.25 Btu•in/(hr•ft²•°F) as the insulation thermal conductivity.
This is a standard value for fiberglass pipe insulation at a 100°F/37.8°C mean temperature.

Pipe heat loss and surface temperature

½" Uponor PEX heat loss at 70°F/21.1°C ambient

Water temp (°F)	Heat loss (btu/hr-ft)				
	No insulation	½" insulation	1" insulation	1½" insulation	2" insulation
30	-6.3	-4.1	-3.2	-2.7	-2.4
40	-4.7	-3.0	-2.4	-2.0	-1.8
50	-3.2	-2.0	-1.6	-1.4	-1.2
60	-1.6	-1.0	-0.8	-0.7	-0.6
70	0.0	0.0	0.0	0.0	0.0
80	1.6	1.0	0.8	0.7	0.6
90	3.2	2.0	1.6	1.4	1.2
100	4.7	3.0	2.4	2.0	1.8
110	6.3	4.1	3.2	2.7	2.4
120	7.9	5.1	4.0	3.4	3.1
130	9.5	6.1	4.7	4.1	3.7
140	11.1	7.1	5.5	4.8	4.3
150	12.6	8.1	6.3	5.4	4.9
160	14.2	9.1	7.1	6.1	5.5
170	15.8	10.1	7.9	6.8	6.1
180	17.4	11.1	8.7	7.5	6.7
190	18.9	12.2	9.5	8.2	7.3
200	20.5	13.2	10.3	8.8	8.0

½" Uponor PEX surface temperature at 70°F/21.1°C ambient

Water temp (°F)	Surface temperature (°F)				
	No insulation	½" insulation	1" insulation	1½" insulation	2" insulation
30	31.4	60.5	65.4	67.1	68.0
40	41.1	62.9	66.5	67.9	68.5
50	50.7	65.2	67.7	68.6	69.0
60	60.4	67.6	68.8	69.3	69.5
70	70.0	70.0	70.0	70.0	70.0
80	79.6	72.4	71.2	70.7	70.5
90	89.3	74.8	72.3	71.4	71.0
100	98.9	77.1	73.5	72.1	71.5
110	108.6	79.5	74.6	72.9	72.0
120	118.2	81.9	75.8	73.6	72.5
130	127.9	84.3	76.9	74.3	73.0
140	137.5	86.7	78.1	75.0	73.5
150	147.2	89.0	79.2	75.7	74.0
160	156.8	91.4	80.4	76.4	74.5
170	166.5	93.8	81.5	77.2	75.1
180	176.1	96.2	82.7	77.9	75.6
190	185.8	98.6	83.8	78.6	76.1
200	195.4	101.0	85.0	79.3	76.6

1. All calculations based on cylindrical thermal resistance methodology (ASHRAE).
2. Based on fluid velocity of 8 ft./sec. at 160°F/71.1°C (maximizing heat transfer from 100% water).
3. Pipe convection set to be 1.00 Btu/hr•ft²•°F (based on standard value for free convection of air).
4. This heat loss comparison uses 0.25 Btu•in/(hr•ft²•°F) as the insulation thermal conductivity.
This is a standard value for fiberglass pipe insulation at a 100°F/37.8°C mean temperature.

Pipe heat loss and surface temperature

¾" Uponor PEX heat loss at 70°F/21.1°C ambient

Water temp (°F)	Heat loss (btu/hr-ft)				
	No insulation	½" insulation	1" insulation	1½" insulation	2" insulation
30	-8.7	-5.0	-3.8	-3.2	-2.8
40	-6.6	-3.7	-2.8	-2.4	-2.1
50	-4.4	-2.5	-1.9	-1.6	-1.4
60	-2.2	-1.2	-0.9	-0.8	-0.7
70	0.0	0.0	0.0	0.0	0.0
80	2.2	1.2	0.9	0.8	0.7
90	4.4	2.5	1.9	1.6	1.4
100	6.6	3.7	2.8	2.4	2.1
110	8.7	5.0	3.8	3.2	2.8
120	10.9	6.2	4.7	4.0	3.5
130	13.1	7.4	5.6	4.8	4.3
140	15.3	8.7	6.6	5.6	5.0
150	17.5	9.9	7.5	6.4	5.7
160	19.7	11.2	8.5	7.2	6.4
170	21.9	12.4	9.4	8.0	7.1
180	24.0	13.6	10.4	8.8	7.8
190	26.2	14.9	11.3	9.6	8.5
200	28.4	16.1	12.2	10.3	9.2

¾" Uponor PEX surface temperature at 70°F/21.1°C ambient

Water temp (°F)	Surface temperature (°F)				
	No insulation	½" insulation	1" insulation	1½" insulation	2" insulation
30	31.8	59.9	65.0	66.9	67.8
40	41.4	62.4	66.2	67.6	68.3
50	50.9	65.0	67.5	68.4	68.9
60	60.5	67.5	68.7	69.2	69.4
70	70.0	70.0	70.0	70.0	70.0
80	79.5	72.5	71.3	70.8	70.6
90	89.1	75.0	72.5	71.6	71.1
100	98.6	77.6	73.8	72.4	71.7
110	108.2	80.1	75.0	73.1	72.2
120	117.7	82.6	76.3	73.9	72.8
130	127.3	85.1	77.5	74.7	73.3
140	136.8	87.7	78.8	75.5	73.9
150	146.3	90.2	80.0	76.3	74.4
160	155.9	92.7	81.3	77.1	75.0
170	165.4	95.2	82.5	77.8	75.6
180	175.0	97.8	83.8	78.6	76.1
190	184.5	100.3	85.0	79.4	76.7
200	194.1	102.8	86.3	80.2	77.2

1. All calculations based on cylindrical thermal resistance methodology (ASHRAE).
2. Based on fluid velocity of 8 ft./sec. at 160°F/71.1°C (maximizing heat transfer from 100% water).
3. Pipe convection set to be 1.00 Btu/hr•ft²•°F (based on standard value for free convection of air).
4. This heat loss comparison uses 0.25 Btu•in/(hr•ft²•°F) as the insulation thermal conductivity.
This is a standard value for fiberglass pipe insulation at a 100°F/37.8°C mean temperature.

Pipe heat loss and surface temperature

1" Uponor PEX heat loss at 70°F/21.1°C ambient

Water temp (°F)	Heat loss (btu/hr-ft)				
	No insulation	½" insulation	1" insulation	1½" insulation	2" insulation
30	-11.1	-5.8	-4.3	-3.6	-3.2
40	-8.3	-4.4	-3.2	-2.7	-2.4
50	-5.5	-2.9	-2.2	-1.8	-1.6
60	-2.8	-1.5	-1.1	-0.9	-0.8
70	0.0	0.0	0.0	0.0	0.0
80	2.8	1.5	1.1	0.9	0.8
90	5.5	2.9	2.2	1.8	1.6
100	8.3	4.4	3.2	2.7	2.4
110	11.1	5.8	4.3	3.6	3.2
120	13.9	7.3	5.4	4.5	4.0
130	16.6	8.7	6.5	5.4	4.8
140	19.4	10.2	7.6	6.3	5.6
150	22.2	11.7	8.7	7.2	6.4
160	25.0	13.1	9.7	8.1	7.2
170	27.7	14.6	10.8	9.0	8.0
180	30.5	16.0	11.9	9.9	8.8
190	33.3	17.5	13.0	10.8	9.6
200	36.1	18.9	14.1	11.8	10.4

1" Uponor PEX surface temperature at 70°F/21.1°C ambient

Water temp (°F)	Surface temperature (°F)				
	No insulation	½" insulation	1" insulation	1½" insulation	2" insulation
30	32.3	59.5	64.7	66.7	67.6
40	41.7	62.1	66.0	67.5	68.2
50	51.2	64.8	67.4	68.3	68.8
60	60.6	67.4	68.7	69.2	69.4
70	70.0	70.0	70.0	70.0	70.0
80	79.4	72.6	71.3	70.8	70.6
90	88.8	75.2	72.6	71.7	71.2
100	98.3	77.9	74.0	72.5	71.8
110	107.7	80.5	75.3	73.3	72.4
120	117.1	83.1	76.6	74.2	73.0
130	126.5	85.7	77.9	75.0	73.6
140	135.9	88.3	79.3	75.9	74.2
150	145.3	90.9	80.6	76.7	74.8
160	154.8	93.6	81.9	77.5	75.3
170	164.2	96.2	83.2	78.4	75.9
180	173.6	98.8	84.6	79.2	76.5
190	183.0	101.4	85.9	80.0	77.1
200	192.4	104.0	87.2	80.9	77.7

1. All calculations based on cylindrical thermal resistance methodology (ASHRAE).
2. Based on fluid velocity of 8 ft./sec. at 160°F/71.1°C (maximizing heat transfer from 100% water).
3. Pipe convection set to be 1.00 Btu/hr•ft²•°F (based on standard value for free convection of air).
4. This heat loss comparison uses 0.25 Btu•in/(hr•ft²•°F) as the insulation thermal conductivity.
This is a standard value for fiberglass pipe insulation at a 100°F/37.8°C mean temperature.

Pipe heat loss and surface temperature

1¼" Uponor PEX heat loss at 70°F/21.1°C ambient

Water temp (°F)	Heat loss (btu/hr-ft)				
	No insulation	½" insulation	1" insulation	1½" insulation	2" insulation
30	-13.4	-6.7	-4.9	-4.0	-3.5
40	-10.0	-5.0	-3.7	-3.0	-2.6
50	-6.7	-3.3	-2.4	-2.0	-1.8
60	-3.3	-1.7	-1.2	-1.0	-0.9
70	0.0	0.0	0.0	0.0	0.0
80	3.3	1.7	1.2	1.0	0.9
90	6.7	3.3	2.4	2.0	1.8
100	10.0	5.0	3.7	3.0	2.6
110	13.4	6.7	4.9	4.0	3.5
120	16.7	8.3	6.1	5.0	4.4
130	20.1	10.0	7.3	6.0	5.3
140	23.4	11.7	8.5	7.1	6.2
150	26.8	13.3	9.8	8.1	7.1
160	30.1	15.0	11.0	9.1	7.9
170	33.5	16.7	12.2	10.1	8.8
180	36.8	18.4	13.4	11.1	9.7
190	40.2	20.0	14.6	12.1	10.6
200	43.5	21.7	15.9	13.1	11.5

1¼" Uponor PEX surface temperature at 70°F/21.1°C ambient

Water temp (°F)	Surface temperature (°F)				
	No insulation	½" insulation	1" insulation	1½" insulation	2" insulation
30	32.8	59.3	64.5	66.5	67.5
40	42.1	61.9	65.9	67.4	68.1
50	51.4	64.6	67.2	68.2	68.7
60	60.7	67.3	68.6	69.1	69.4
70	70.0	70.0	70.0	70.0	70.0
80	79.3	72.7	71.4	70.9	70.6
90	88.6	75.4	72.8	71.8	71.3
100	97.9	78.1	74.1	72.6	71.9
110	107.2	80.7	75.5	73.5	72.5
120	116.5	83.4	76.9	74.4	73.1
130	125.8	86.1	78.3	75.3	73.8
140	135.1	88.8	79.7	76.2	74.4
150	144.4	91.5	81.0	77.0	75.0
160	153.7	94.2	82.4	77.9	75.6
170	163.0	96.8	83.8	78.8	76.3
180	172.3	99.5	85.2	79.7	76.9
190	181.6	102.2	86.6	80.6	77.5
200	190.9	104.9	87.9	81.4	78.2

1. All calculations based on cylindrical thermal resistance methodology (ASHRAE).
2. Based on fluid velocity of 8 ft./sec. at 160°F/71.1°C (maximizing heat transfer from 100% water).
3. Pipe convection set to be 1.00 Btu/hr•ft²•°F (based on standard value for free convection of air).
4. This heat loss comparison uses 0.25 Btu•in/(hr•ft²•°F) as the insulation thermal conductivity. This is a standard value for fiberglass pipe insulation at a 100°F/37.8°C mean temperature.

Pipe heat loss and surface temperature

1½" Uponor PEX heat loss at 70°F/21.1°C ambient

Water temp (°F)	Heat loss (btu/hr-ft)				
	No insulation	½" insulation	1" insulation	1½" insulation	2" insulation
30	-15.6	-7.5	-5.4	-4.4	-3.9
40	-11.7	-5.6	-4.1	-3.3	-2.9
50	-7.8	-3.8	-2.7	-2.2	-1.9
60	-3.9	-1.9	-1.4	-1.1	-1.0
70	0.0	0.0	0.0	0.0	0.0
80	3.9	1.9	1.4	1.1	1.0
90	7.8	3.8	2.7	2.2	1.9
100	11.7	5.6	4.1	3.3	2.9
110	15.6	7.5	5.4	4.4	3.9
120	19.5	9.4	6.8	5.5	4.8
130	23.4	11.3	8.1	6.6	5.8
140	27.3	13.1	9.5	7.8	6.7
150	31.2	15.0	10.8	8.9	7.7
160	35.1	16.9	12.2	10.0	8.7
170	39.0	18.8	13.5	11.1	9.6
180	43.0	20.6	14.9	12.2	10.6
190	46.9	22.5	16.2	13.3	11.6
200	50.8	24.4	17.6	14.4	12.5

1½" Uponor PEX surface temperature at 70°F/21.1°C ambient

Water temp (°F)	Surface temperature (°F)				
	No insulation	½" insulation	1" insulation	1½" insulation	2" insulation
30	33.3	59.1	64.3	66.3	67.4
40	42.5	61.8	65.7	67.3	68.0
50	51.6	64.5	67.1	68.2	68.7
60	60.8	67.3	68.6	69.1	69.3
70	70.0	70.0	70.0	70.0	70.0
80	79.2	72.7	71.4	70.9	70.7
90	88.4	75.5	72.9	71.8	71.3
100	97.5	78.2	74.3	72.7	72.0
110	106.7	80.9	75.7	73.7	72.6
120	115.9	83.7	77.1	74.6	73.3
130	125.1	86.4	78.6	75.5	73.9
140	134.2	89.1	80.0	76.4	74.6
150	143.4	91.8	81.4	77.3	75.2
160	152.6	94.6	82.8	78.2	75.9
170	161.8	97.3	84.3	79.1	76.5
180	171.0	100.0	85.7	80.1	77.2
190	180.1	102.8	87.1	81.0	77.9
200	189.3	105.5	88.5	81.9	78.5

1. All calculations based on cylindrical thermal resistance methodology (ASHRAE).
2. Based on fluid velocity of 8 ft./sec. at 160°F/71.1°C (maximizing heat transfer from 100% water).
3. Pipe convection set to be 1.00 Btu/hr•ft²•°F (based on standard value for free convection of air).
4. This heat loss comparison uses 0.25 Btu•in/(hr•ft²•°F) as the insulation thermal conductivity. This is a standard value for fiberglass pipe insulation at a 100°F/37.8°C mean temperature.

Pipe heat loss and surface temperature

2" Uponor PEX heat loss at 70°F/21.1°C ambient

Water temp (°F)	Heat loss (btu/hr-ft)				
	No insulation	½" insulation	1" insulation	1½" insulation	2" insulation
30	-19.9	-9.1	-6.4	-5.2	-4.5
40	-14.9	-6.9	-4.8	-3.9	-3.4
50	-10.0	-4.6	-3.2	-2.6	-2.2
60	-5.0	-2.3	-1.6	-1.3	-1.1
70	0.0	0.0	0.0	0.0	0.0
80	5.0	2.3	1.6	1.3	1.1
90	10.0	4.6	3.2	2.6	2.2
100	14.9	6.9	4.8	3.9	3.4
110	19.9	9.1	6.4	5.2	4.5
120	24.9	11.4	8.1	6.5	5.6
130	29.9	13.7	9.7	7.8	6.7
140	34.9	16.0	11.3	9.1	7.8
150	39.9	18.3	12.9	10.4	9.0
160	44.8	20.6	14.5	11.7	10.1
170	49.8	22.8	16.1	13.0	11.2
180	54.8	25.1	17.7	14.3	12.3
190	59.8	27.4	19.3	15.6	13.5
200	64.8	29.7	21.0	16.9	14.6

2" Uponor PEX surface temperature at 70°F/21.1°C ambient

Water temp (°F)	Surface temperature (°F)				
	No insulation	½" insulation	1" insulation	1½" insulation	2" insulation
30	34.2	58.8	64.0	66.1	67.2
40	43.1	61.6	65.5	67.1	67.9
50	52.1	64.4	67.0	68.1	68.6
60	61.0	67.2	68.5	69.0	69.3
70	70.0	70.0	70.0	70.0	70.0
80	79.0	72.8	71.5	71.0	70.7
90	87.9	75.6	73.0	71.9	71.4
100	96.9	78.4	74.5	72.9	72.1
110	105.8	81.2	76.0	73.9	72.8
120	114.8	84.0	77.5	74.9	73.5
130	123.7	86.8	79.0	75.8	74.2
140	132.7	89.5	80.5	76.8	74.9
150	141.7	92.3	81.9	77.8	75.6
160	150.6	95.1	83.4	78.7	76.3
170	159.6	97.9	84.9	79.7	77.0
180	168.5	100.7	86.4	80.7	77.7
190	177.5	103.5	87.9	81.6	78.4
200	186.4	106.3	89.4	82.6	79.1

1. All calculations based on cylindrical thermal resistance methodology (ASHRAE).
2. Based on fluid velocity of 8 ft./sec. at 160°F/71.1°C (maximizing heat transfer from 100% water).
3. Pipe convection set to be 1.00 Btu/hr•ft²•°F (based on standard value for free convection of air).
4. This heat loss comparison uses 0.25 Btu•in/(hr•ft²•°F) as the insulation thermal conductivity.
This is a standard value for fiberglass pipe insulation at a 100°F/37.8°C mean temperature.

Pipe heat loss and surface temperature

2½" Uponor PEX heat loss at 70°F/21.1°C ambient

Water temp (°F)	Heat loss (btu/hr-ft)				
	No insulation	½" insulation	1" insulation	1½" insulation	2" insulation
30	-24.0	-10.7	-7.5	-6.0	-5.1
40	-18.0	-8.0	-5.6	-4.5	-3.8
50	-12.0	-5.4	-3.7	-3.0	-2.5
60	-6.0	-2.7	-1.9	-1.5	-1.3
70	0.0	0.0	0.0	0.0	0.0
80	6.0	2.7	1.9	1.5	1.3
90	12.0	5.4	3.7	3.0	2.5
100	18.0	8.0	5.6	4.5	3.8
110	24.0	10.7	7.5	6.0	5.1
120	30.0	13.4	9.3	7.5	6.4
130	36.0	16.1	11.2	8.9	7.6
140	42.0	18.8	13.1	10.4	8.9
150	48.0	21.5	14.9	11.9	10.2
160	54.1	24.1	16.8	13.4	11.5
170	60.1	26.8	18.6	14.9	12.7
180	66.1	29.5	20.5	16.4	14.0
190	72.1	32.2	22.4	17.9	15.3
200	78.1	34.9	24.2	19.4	16.5

2½" Uponor PEX surface temperature at 70°F/21.1°C ambient

Water temp (°F)	Surface temperature (°F)				
	No insulation	½" insulation	1" insulation	1½" insulation	2" insulation
30	35.0	58.7	63.8	66.0	67.1
40	43.8	61.5	65.4	67.0	67.8
50	52.5	64.3	66.9	68.0	68.5
60	61.3	67.2	68.5	69.0	69.3
70	70.0	70.0	70.0	70.0	70.0
80	78.7	72.8	71.5	71.0	70.7
90	87.5	75.7	73.1	72.0	71.5
100	96.2	78.5	74.6	73.0	72.2
110	105.0	81.3	76.2	74.0	72.9
120	113.7	84.1	77.7	75.1	73.7
130	122.4	87.0	79.2	76.1	74.4
140	131.2	89.8	80.8	77.1	75.1
150	139.9	92.6	82.3	78.1	75.9
160	148.7	95.4	83.9	79.1	76.6
170	157.4	98.3	85.4	80.1	77.3
180	166.1	101.1	86.9	81.1	78.1
190	174.9	103.9	88.5	82.1	78.8
200	183.6	106.7	90.0	83.2	79.5

1. All calculations based on cylindrical thermal resistance methodology (ASHRAE).
2. Based on fluid velocity of 8 ft./sec. at 160°F/71.1°C (maximizing heat transfer from 100% water).
3. Pipe convection set to be 1.00 Btu/hr•ft²•°F (based on standard value for free convection of air).
4. This heat loss comparison uses 0.25 Btu•in/(hr•ft²•°F) as the insulation thermal conductivity.
This is a standard value for fiberglass pipe insulation at a 100°F/37.8°C mean temperature.

Pipe heat loss and surface temperature

3" Uponor PEX heat loss at 70°F/21.1°C ambient

Water temp (°F)	Heat loss (btu/hr-ft)				
	No insulation	½" insulation	1" insulation	1½" insulation	2" insulation
30	-28.0	-12.3	-8.5	-6.7	-5.7
40	-21.0	-9.2	-6.3	-5.0	-4.3
50	-14.0	-6.1	-4.2	-3.3	-2.8
60	-7.0	-3.1	-2.1	-1.7	-1.4
70	0.0	0.0	0.0	0.0	0.0
80	7.0	3.1	2.1	1.7	1.4
90	14.0	6.1	4.2	3.3	2.8
100	21.0	9.2	6.3	5.0	4.3
110	28.0	12.3	8.5	6.7	5.7
120	34.9	15.4	10.6	8.4	7.1
130	41.9	18.4	12.7	10.0	8.5
140	48.9	21.5	14.8	11.7	9.9
150	55.9	24.6	16.9	13.4	11.4
160	62.9	27.6	19.0	15.1	12.8
170	69.9	30.7	21.1	16.7	14.2
180	76.9	33.8	23.2	18.4	15.6
190	83.9	36.9	25.4	20.1	17.0
200	90.8	39.9	27.5	21.8	18.5

3" Uponor PEX surface temperature at 70°F/21.1°C ambient

Water temp (°F)	Surface temperature (°F)				
	No insulation	½" insulation	1" insulation	1½" insulation	2" insulation
30	35.8	58.6	63.7	65.8	67.0
40	44.4	61.5	65.3	66.9	67.7
50	52.9	64.3	66.9	67.9	68.5
60	61.5	67.2	68.4	69.0	69.2
70	70.0	70.0	70.0	70.0	70.0
80	78.5	72.8	71.6	71.0	70.8
90	87.1	75.7	73.1	72.1	71.5
100	95.6	78.5	74.7	73.1	72.3
110	104.2	81.4	76.3	74.2	73.0
120	112.7	84.2	77.9	75.2	73.8
130	121.3	87.1	79.4	76.3	74.6
140	129.8	89.9	81.0	77.3	75.3
150	138.3	92.8	82.6	78.4	76.1
160	146.9	95.6	84.2	79.4	76.9
170	155.4	98.4	85.7	80.4	77.6
180	164.0	101.3	87.3	81.5	78.4
190	172.5	104.1	88.9	82.5	79.1
200	181.0	107.0	90.5	83.6	79.9

1. All calculations based on cylindrical thermal resistance methodology (ASHRAE).
2. Based on fluid velocity of 8 ft./sec. at 160°F/71.1°C (maximizing heat transfer from 100% water).
3. Pipe convection set to be 1.00 Btu/hr•ft²•°F (based on standard value for free convection of air).
4. This heat loss comparison uses 0.25 Btu•in/(hr•ft²•°F) as the insulation thermal conductivity.
This is a standard value for fiberglass pipe insulation at a 100°F/37.8°C mean temperature.

Pipe heat loss and surface temperature

½" Uponor PEX heat loss at 90°F/32.2°C ambient

Water temp (°F)	Heat loss (btu/hr-ft)				
	No insulation	½" insulation	1" insulation	1½" insulation	2" insulation
30	-9.5	-6.1	-4.7	-4.1	-3.7
40	-7.9	-5.1	-4.0	-3.4	-3.1
50	-6.3	-4.1	-3.2	-2.7	-2.4
60	-4.7	-3.0	-2.4	-2.0	-1.8
70	-3.2	-2.0	-1.6	-1.4	-1.2
80	-1.6	-1.0	-0.8	-0.7	-0.6
90	0.0	0.0	0.0	0.0	0.0
100	1.6	1.0	0.8	0.7	0.6
110	3.2	2.0	1.6	1.4	1.2
120	4.7	3.0	2.4	2.0	1.8
130	6.3	4.1	3.2	2.7	2.4
140	7.9	5.1	4.0	3.4	3.1
150	9.5	6.1	4.7	4.1	3.7
160	11.1	7.1	5.5	4.8	4.3
170	12.6	8.1	6.3	5.4	4.9
180	14.2	9.1	7.1	6.1	5.5
190	15.8	10.1	7.9	6.8	6.1
200	17.4	11.1	8.7	7.5	6.7

½" Uponor PEX surface temperature at 90°F/32.2°C ambient

Water temp (°F)	Surface temperature (°F)				
	No insulation	½" insulation	1" insulation	1½" insulation	2" insulation
30	32.1	75.7	83.1	85.7	87.0
40	41.8	78.1	84.2	86.4	87.5
50	51.4	80.5	85.4	87.1	88.0
60	61.1	82.9	86.5	87.9	88.5
70	70.7	85.2	87.7	88.6	89.0
80	80.4	87.6	88.8	89.3	89.5
90	90.0	90.0	90.0	90.0	90.0
100	99.6	92.4	91.2	90.7	90.5
110	109.3	94.8	92.3	91.4	91.0
120	118.9	97.1	93.5	92.1	91.5
130	128.6	99.5	94.6	92.9	92.0
140	138.2	101.9	95.8	93.6	92.5
150	147.9	104.3	96.9	94.3	93.0
160	157.5	106.7	98.1	95.0	93.5
170	167.2	109.0	99.2	95.7	94.0
180	176.8	111.4	100.4	96.4	94.5
190	186.5	113.8	101.5	97.2	95.1
200	196.1	116.2	102.7	97.9	95.6

1. All calculations based on cylindrical thermal resistance methodology (ASHRAE).
2. Based on fluid velocity of 8 ft./sec. at 160°F/71.1°C (maximizing heat transfer from 100% water).
3. Pipe convection set to be 1.00 Btu/hr•ft²•°F (based on standard value for free convection of air).
4. This heat loss comparison uses 0.25 Btu•in/(hr•ft²•°F) as the insulation thermal conductivity.
This is a standard value for fiberglass pipe insulation at a 100°F/37.8°C mean temperature.

Pipe heat loss and surface temperature

¾" Uponor PEX heat loss at 90°F/32.2°C ambient

Water temp (°F)	Heat loss (btu/hr-ft)				
	No insulation	½" insulation	1" insulation	1½" insulation	2" insulation
30	-13.1	-7.4	-5.6	-4.8	-4.3
40	-10.9	-6.2	-4.7	-4.0	-3.5
50	-8.7	-5.0	-3.8	-3.2	-2.8
60	-6.6	-3.7	-2.8	-2.4	-2.1
70	-4.4	-2.5	-1.9	-1.6	-1.4
80	-2.2	-1.2	-0.9	-0.8	-0.7
90	0.0	0.0	0.0	0.0	0.0
100	2.2	1.2	0.9	0.8	0.7
110	4.4	2.5	1.9	1.6	1.4
120	6.6	3.7	2.8	2.4	2.1
130	8.7	5.0	3.8	3.2	2.8
140	10.9	6.2	4.7	4.0	3.5
150	13.1	7.4	5.6	4.8	4.3
160	15.3	8.7	6.6	5.6	5.0
170	17.5	9.9	7.5	6.4	5.7
180	19.7	11.2	8.5	7.2	6.4
190	21.9	12.4	9.4	8.0	7.1
200	24.0	13.6	10.4	8.8	7.8

¾" Uponor PEX surface temperature at 90°F/32.2°C ambient

Water temp (°F)	Surface temperature (°F)				
	No insulation	½" insulation	1" insulation	1½" insulation	2" insulation
30	32.7	74.9	82.5	85.3	86.7
40	42.3	77.4	83.7	86.1	87.2
50	51.8	79.9	85.0	86.9	87.8
60	61.4	82.4	86.2	87.6	88.3
70	70.9	85.0	87.5	88.4	88.9
80	80.5	87.5	88.7	89.2	89.4
90	90.0	90.0	90.0	90.0	90.0
100	99.5	92.5	91.3	90.8	90.6
110	109.1	95.0	92.5	91.6	91.1
120	118.6	97.6	93.8	92.4	91.7
130	128.2	100.1	95.0	93.1	92.2
140	137.7	102.6	96.3	93.9	92.8
150	147.3	105.1	97.5	94.7	93.3
160	156.8	107.7	98.8	95.5	93.9
170	166.3	110.2	100.0	96.3	94.4
180	175.9	112.7	101.3	97.1	95.0
190	185.4	115.2	102.5	97.8	95.6
200	195.0	117.8	103.8	98.6	96.1

1. All calculations based on cylindrical thermal resistance methodology (ASHRAE).
2. Based on fluid velocity of 8 ft./sec. at 160°F/71.1°C (maximizing heat transfer from 100% water).
3. Pipe convection set to be 1.00 Btu/hr•ft²•°F (based on standard value for free convection of air).
4. This heat loss comparison uses 0.25 Btu•in/(hr•ft²•°F) as the insulation thermal conductivity.
This is a standard value for fiberglass pipe insulation at a 100°F/37.8°C mean temperature.

Pipe heat loss and surface temperature

1" Uponor PEX heat loss at 90°F/32.2°C ambient

Water temp (°F)	Heat loss (btu/hr-ft)				
	No insulation	½" insulation	1" insulation	1½" insulation	2" insulation
30	-16.6	-8.7	-6.5	-5.4	-4.8
40	-13.9	-7.3	-5.4	-4.5	-4.0
50	-11.1	-5.8	-4.3	-3.6	-3.2
60	-8.3	-4.4	-3.2	-2.7	-2.4
70	-5.5	-2.9	-2.2	-1.8	-1.6
80	-2.8	-1.5	-1.1	-0.9	-0.8
90	0.0	0.0	0.0	0.0	0.0
100	2.8	1.5	1.1	0.9	0.8
110	5.5	2.9	2.2	1.8	1.6
120	8.3	4.4	3.2	2.7	2.4
130	11.1	5.8	4.3	3.6	3.2
140	13.9	7.3	5.4	4.5	4.0
150	16.6	8.7	6.5	5.4	4.8
160	19.4	10.2	7.6	6.3	5.6
170	22.2	11.7	8.7	7.2	6.4
180	25.0	13.1	9.7	8.1	7.2
190	27.7	14.6	10.8	9.0	8.0
200	30.5	16.0	11.9	9.9	8.8

1" Uponor PEX surface temperature at 90°F/32.2°C ambient

Water temp (°F)	Surface temperature (°F)				
	No insulation	½" insulation	1" insulation	1½" insulation	2" insulation
30	33.5	74.3	82.1	85.0	86.4
40	42.9	76.9	83.4	85.8	87.0
50	52.3	79.5	84.7	86.7	87.6
60	61.7	82.1	86.0	87.5	88.2
70	71.2	84.8	87.4	88.3	88.8
80	80.6	87.4	88.7	89.2	89.4
90	90.0	90.0	90.0	90.0	90.0
100	99.4	92.6	91.3	90.8	90.6
110	108.8	95.2	92.6	91.7	91.2
120	118.3	97.9	94.0	92.5	91.8
130	127.7	100.5	95.3	93.3	92.4
140	137.1	103.1	96.6	94.2	93.0
150	146.5	105.7	97.9	95.0	93.6
160	155.9	108.3	99.3	95.9	94.2
170	165.3	110.9	100.6	96.7	94.8
180	174.8	113.6	101.9	97.5	95.3
190	184.2	116.2	103.2	98.4	95.9
200	193.6	118.8	104.6	99.2	96.5

1. All calculations based on cylindrical thermal resistance methodology (ASHRAE).
2. Based on fluid velocity of 8 ft./sec. at 160°F/71.1°C (maximizing heat transfer from 100% water).
3. Pipe convection set to be 1.00 Btu/hr•ft²•°F (based on standard value for free convection of air).
4. This heat loss comparison uses 0.25 Btu•in/(hr•ft²•°F) as the insulation thermal conductivity.
This is a standard value for fiberglass pipe insulation at a 100°F/37.8°C mean temperature.

Pipe heat loss and surface temperature

1¼" Uponor PEX heat loss at 90°F/32.2°C ambient

Water temp (°F)	Heat loss (btu/hr-ft)				
	No insulation	½" insulation	1" insulation	1½" insulation	2" insulation
30	-20.1	-10.0	-7.3	-6.0	-5.3
40	-16.7	-8.3	-6.1	-5.0	-4.4
50	-13.4	-6.7	-4.9	-4.0	-3.5
60	-10.0	-5.0	-3.7	-3.0	-2.6
70	-6.7	-3.3	-2.4	-2.0	-1.8
80	-3.3	-1.7	-1.2	-1.0	-0.9
90	0.0	0.0	0.0	0.0	0.0
100	3.3	1.7	1.2	1.0	0.9
110	6.7	3.3	2.4	2.0	1.8
120	10.0	5.0	3.7	3.0	2.6
130	13.4	6.7	4.9	4.0	3.5
140	16.7	8.3	6.1	5.0	4.4
150	20.1	10.0	7.3	6.0	5.3
160	23.4	11.7	8.5	7.1	6.2
170	26.8	13.3	9.8	8.1	7.1
180	30.1	15.0	11.0	9.1	7.9
190	33.5	16.7	12.2	10.1	8.8
200	36.8	18.4	13.4	11.1	9.7

1¼" Uponor PEX surface temperature at 90°F/32.2°C ambient

Water temp (°F)	Surface temperature (°F)				
	No insulation	½" insulation	1" insulation	1½" insulation	2" insulation
30	34.2	73.9	81.7	84.7	86.2
40	43.5	76.6	83.1	85.6	86.9
50	52.8	79.3	84.5	86.5	87.5
60	62.1	81.9	85.9	87.4	88.1
70	71.4	84.6	87.2	88.2	88.7
80	80.7	87.3	88.6	89.1	89.4
90	90.0	90.0	90.0	90.0	90.0
100	99.3	92.7	91.4	90.9	90.6
110	108.6	95.4	92.8	91.8	91.3
120	117.9	98.1	94.1	92.6	91.9
130	127.2	100.7	95.5	93.5	92.5
140	136.5	103.4	96.9	94.4	93.1
150	145.8	106.1	98.3	95.3	93.8
160	155.1	108.8	99.7	96.2	94.4
170	164.4	111.5	101.0	97.0	95.0
180	173.7	114.2	102.4	97.9	95.6
190	183.0	116.8	103.8	98.8	96.3
200	192.3	119.5	105.2	99.7	96.9

1. All calculations based on cylindrical thermal resistance methodology (ASHRAE).
2. Based on fluid velocity of 8 ft./sec. at 160°F/71.1°C (maximizing heat transfer from 100% water).
3. Pipe convection set to be 1.00 Btu/hr•ft²•°F (based on standard value for free convection of air).
4. This heat loss comparison uses 0.25 Btu•in/(hr•ft²•°F) as the insulation thermal conductivity.
This is a standard value for fiberglass pipe insulation at a 100°F/37.8°C mean temperature.

Pipe heat loss and surface temperature

1½" Uponor PEX heat loss at 90°F/32.2°C ambient

Water temp (°F)	Heat loss (btu/hr-ft)				
	No insulation	½" insulation	1" insulation	1½" insulation	2" insulation
30	-23.4	-11.3	-8.1	-6.6	-5.8
40	-19.5	-9.4	-6.8	-5.5	-4.8
50	-15.6	-7.5	-5.4	-4.4	-3.9
60	-11.7	-5.6	-4.1	-3.3	-2.9
70	-7.8	-3.8	-2.7	-2.2	-1.9
80	-3.9	-1.9	-1.4	-1.1	-1.0
90	0.0	0.0	0.0	0.0	0.0
100	3.9	1.9	1.4	1.1	1.0
110	7.8	3.8	2.7	2.2	1.9
120	11.7	5.6	4.1	3.3	2.9
130	15.6	7.5	5.4	4.4	3.9
140	19.5	9.4	6.8	5.5	4.8
150	23.4	11.3	8.1	6.6	5.8
160	27.3	13.1	9.5	7.8	6.7
170	31.2	15.0	10.8	8.9	7.7
180	35.1	16.9	12.2	10.0	8.7
190	39.0	18.8	13.5	11.1	9.6
200	43.0	20.6	14.9	12.2	10.6

1½" Uponor PEX surface temperature at 90°F/32.2°C ambient

Water temp (°F)	Surface temperature (°F)				
	No insulation	½" insulation	1" insulation	1½" insulation	2" insulation
30	34.9	73.6	81.4	84.5	86.1
40	44.1	76.3	82.9	85.4	86.7
50	53.3	79.1	84.3	86.3	87.4
60	62.5	81.8	85.7	87.3	88.0
70	71.6	84.5	87.1	88.2	88.7
80	80.8	87.3	88.6	89.1	89.3
90	90.0	90.0	90.0	90.0	90.0
100	99.2	92.7	91.4	90.9	90.7
110	108.4	95.5	92.9	91.8	91.3
120	117.5	98.2	94.3	92.7	92.0
130	126.7	100.9	95.7	93.7	92.6
140	135.9	103.7	97.1	94.6	93.3
150	145.1	106.4	98.6	95.5	93.9
160	154.2	109.1	100.0	96.4	94.6
170	163.4	111.8	101.4	97.3	95.2
180	172.6	114.6	102.8	98.2	95.9
190	181.8	117.3	104.3	99.1	96.5
200	191.0	120.0	105.7	100.1	97.2

1. All calculations based on cylindrical thermal resistance methodology (ASHRAE).
2. Based on fluid velocity of 8 ft./sec. at 160°F/71.1°C (maximizing heat transfer from 100% water).
3. Pipe convection set to be 1.00 Btu/hr•ft²•°F (based on standard value for free convection of air).
4. This heat loss comparison uses 0.25 Btu•in/(hr•ft²•°F) as the insulation thermal conductivity.
This is a standard value for fiberglass pipe insulation at a 100°F/37.8°C mean temperature.

Pipe heat loss and surface temperature

2" Uponor PEX heat loss at 90°F/32.2°C ambient

Water temp (°F)	Heat loss (btu/hr-ft)				
	No insulation	½" insulation	1" insulation	1½" insulation	2" insulation
30	-29.9	-13.7	-9.7	-7.8	-6.7
40	-24.9	-11.4	-8.1	-6.5	-5.6
50	-19.9	-9.1	-6.4	-5.2	-4.5
60	-14.9	-6.9	-4.8	-3.9	-3.4
70	-10.0	-4.6	-3.2	-2.6	-2.2
80	-5.0	-2.3	-1.6	-1.3	-1.1
90	0.0	0.0	0.0	0.0	0.0
100	5.0	2.3	1.6	1.3	1.1
110	10.0	4.6	3.2	2.6	2.2
120	14.9	6.9	4.8	3.9	3.4
130	19.9	9.1	6.4	5.2	4.5
140	24.9	11.4	8.1	6.5	5.6
150	29.9	13.7	9.7	7.8	6.7
160	34.9	16.0	11.3	9.1	7.8
170	39.9	18.3	12.9	10.4	9.0
180	44.8	20.6	14.5	11.7	10.1
190	49.8	22.8	16.1	13.0	11.2
200	54.8	25.1	17.7	14.3	12.3

2" Uponor PEX surface temperature at 90°F/32.2°C ambient

Water temp (°F)	Surface temperature (°F)				
	No insulation	½" insulation	1" insulation	1½" insulation	2" insulation
30	36.3	73.2	81.0	84.2	85.8
40	45.2	76.0	82.5	85.1	86.5
50	54.2	78.8	84.0	86.1	87.2
60	63.1	81.6	85.5	87.1	87.9
70	72.1	84.4	87.0	88.1	88.6
80	81.0	87.2	88.5	89.0	89.3
90	90.0	90.0	90.0	90.0	90.0
100	99.0	92.8	91.5	91.0	90.7
110	107.9	95.6	93.0	91.9	91.4
120	116.9	98.4	94.5	92.9	92.1
130	125.8	101.2	96.0	93.9	92.8
140	134.8	104.0	97.5	94.9	93.5
150	143.7	106.8	99.0	95.8	94.2
160	152.7	109.5	100.5	96.8	94.9
170	161.7	112.3	101.9	97.8	95.6
180	170.6	115.1	103.4	98.7	96.3
190	179.6	117.9	104.9	99.7	97.0
200	188.5	120.7	106.4	100.7	97.7

1. All calculations based on cylindrical thermal resistance methodology (ASHRAE).
2. Based on fluid velocity of 8 ft./sec. at 160°F/71.1°C (maximizing heat transfer from 100% water).
3. Pipe convection set to be 1.00 Btu/hr•ft²•°F (based on standard value for free convection of air).
4. This heat loss comparison uses 0.25 Btu•in/(hr•ft²•°F) as the insulation thermal conductivity.
This is a standard value for fiberglass pipe insulation at a 100°F/37.8°C mean temperature.

Pipe heat loss and surface temperature

2½" Uponor PEX heat loss at 90°F/32.2°C ambient

Water temp (°F)	Heat loss (btu/hr-ft)				
	No insulation	½" insulation	1" insulation	1½" insulation	2" insulation
30	-36.0	-16.1	-11.2	-8.9	-7.6
40	-30.0	-13.4	-9.3	-7.5	-6.4
50	-24.0	-10.7	-7.5	-6.0	-5.1
60	-18.0	-8.0	-5.6	-4.5	-3.8
70	-12.0	-5.4	-3.7	-3.0	-2.5
80	-6.0	-2.7	-1.9	-1.5	-1.3
90	0.0	0.0	0.0	0.0	0.0
100	6.0	2.7	1.9	1.5	1.3
110	12.0	5.4	3.7	3.0	2.5
120	18.0	8.0	5.6	4.5	3.8
130	24.0	10.7	7.5	6.0	5.1
140	30.0	13.4	9.3	7.5	6.4
150	36.0	16.1	11.2	8.9	7.6
160	42.0	18.8	13.1	10.4	8.9
170	48.0	21.5	14.9	11.9	10.2
180	54.1	24.1	16.8	13.4	11.5
190	60.1	26.8	18.6	14.9	12.7
200	66.1	29.5	20.5	16.4	14.0

2½" Uponor PEX surface temperature at 90°F/32.2°C ambient

Water temp (°F)	Surface temperature (°F)				
	No insulation	½" insulation	1" insulation	1½" insulation	2" insulation
30	37.6	73.0	80.8	83.9	85.6
40	46.3	75.9	82.3	84.9	86.3
50	55.0	78.7	83.8	86.0	87.1
60	63.8	81.5	85.4	87.0	87.8
70	72.5	84.3	86.9	88.0	88.5
80	81.3	87.2	88.5	89.0	89.3
90	90.0	90.0	90.0	90.0	90.0
100	98.7	92.8	91.5	91.0	90.7
110	107.5	95.7	93.1	92.0	91.5
120	116.2	98.5	94.6	93.0	92.2
130	125.0	101.3	96.2	94.0	92.9
140	133.7	104.1	97.7	95.1	93.7
150	142.4	107.0	99.2	96.1	94.4
160	151.2	109.8	100.8	97.1	95.1
170	159.9	112.6	102.3	98.1	95.9
180	168.7	115.4	103.9	99.1	96.6
190	177.4	118.3	105.4	100.1	97.3
200	186.1	121.1	106.9	101.1	98.1

1. All calculations based on cylindrical thermal resistance methodology (ASHRAE).
2. Based on fluid velocity of 8 ft./sec. at 160°F/71.1°C (maximizing heat transfer from 100% water).
3. Pipe convection set to be 1.00 Btu/hr•ft²•°F (based on standard value for free convection of air).
4. This heat loss comparison uses 0.25 Btu•in/(hr•ft²•°F) as the insulation thermal conductivity. This is a standard value for fiberglass pipe insulation at a 100°F/37.8°C mean temperature.

Pipe heat loss and surface temperature

3" Uponor PEX-a heat loss at 90°F/32.2°C ambient

Water temp (°F)	Heat loss (btu/hr-ft)				
	No insulation	½" insulation	1" insulation	1½" insulation	2" insulation
30	-41.9	-18.4	-12.7	-10.0	-8.5
40	-34.9	-15.4	-10.6	-8.4	-7.1
50	-28.0	-12.3	-8.5	-6.7	-5.7
60	-21.0	-9.2	-6.3	-5.0	-4.3
70	-14.0	-6.1	-4.2	-3.3	-2.8
80	-7.0	-3.1	-2.1	-1.7	-1.4
90	0.0	0.0	0.0	0.0	0.0
100	7.0	3.1	2.1	1.7	1.4
110	14.0	6.1	4.2	3.3	2.8
120	21.0	9.2	6.3	5.0	4.3
130	28.0	12.3	8.5	6.7	5.7
140	34.9	15.4	10.6	8.4	7.1
150	41.9	18.4	12.7	10.0	8.5
160	48.9	21.5	14.8	11.7	9.9
170	55.9	24.6	16.9	13.4	11.4
180	62.9	27.6	19.0	15.1	12.8
190	69.9	30.7	21.1	16.7	14.2
200	76.9	33.8	23.2	18.4	15.6

3" Uponor PEX surface temperature at 90°F/32.2°C ambient

Water temp (°F)	Surface temperature (°F)				
	No insulation	½" insulation	1" insulation	1½" insulation	2" insulation
30	38.7	72.9	80.6	83.7	85.4
40	47.3	75.8	82.1	84.8	86.2
50	55.8	78.6	83.7	85.8	87.0
60	64.4	81.5	85.3	86.9	87.7
70	72.9	84.3	86.9	87.9	88.5
80	81.5	87.2	88.4	89.0	89.2
90	90.0	90.0	90.0	90.0	90.0
100	98.5	92.8	91.6	91.0	90.8
110	107.1	95.7	93.1	92.1	91.5
120	115.6	98.5	94.7	93.1	92.3
130	124.2	101.4	96.3	94.2	93.0
140	132.7	104.2	97.9	95.2	93.8
150	141.3	107.1	99.4	96.3	94.6
160	149.8	109.9	101.0	97.3	95.3
170	158.3	112.8	102.6	98.4	96.1
180	166.9	115.6	104.2	99.4	96.9
190	175.4	118.4	105.7	100.4	97.6
200	184.0	121.3	107.3	101.5	98.4

1. All calculations based on cylindrical thermal resistance methodology (ASHRAE).
2. Based on fluid velocity of 8 ft./sec. at 160°F/71.1°C (maximizing heat transfer from 100% water).
3. Pipe convection set to be 1.00 Btu/hr•ft²•°F (based on standard value for free convection of air).
4. This heat loss comparison uses 0.25 Btu•in/(hr•ft²•°F) as the insulation thermal conductivity.
This is a standard value for fiberglass pipe insulation at a 100°F/37.8°C mean temperature.



Uponor Inc.
5925 148th Street West
Apple Valley, MN 55124
USA

T 800.321.4739
F 952.891.2008

Uponor Ltd.
6510 Kennedy Road
Mississauga, ON L5T 2X4
CANADA

T 888.994.7726
F 800.638.9517

uponor

uponorengineering.com

ProPEX lead-free (LF) brass commercial ball valves

Project Information

Job name:	Location:
Engineer:	Date submitted:
Contractor:	Submitted by:
Manufacturer's representative:	Approved by:

Technical data

Cold working pressure	250 psi
Temp/pressure ratings	200 °F (93 °C) at 200 psi (13.8 bar)

Product information and application use

To help meet the stringent demands of commercial plumbing and hydronic distribution projects, Uponor is offering new ProPEX® ASTM F1960 lead-free (LF) brass ball valves in sizes from ½" to 2". The full-port ball valves feature a stainless-steel ball and stem for greater durability, longevity, and system performance.

Note: Temperature and pressure ratings stated are hydrostatic ratings. For domestic hot-water (DHW) and DHW recirculation installations, operating conditions should not exceed 140°F (60°C) at 80 psi (5.5 bar) in accordance with ASTM F2023. For additional information regarding application-specific temperature and pressure ratings, refer to the Uponor PEX Piping Systems Design and Installation Manual.

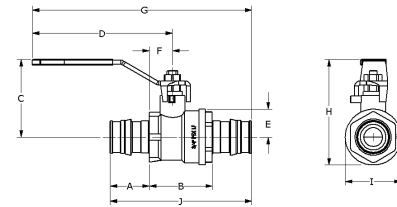

Part name	Part no.	A [inch]	B [inch]	C [inch]	D [inch]	E [inch]	F [inch]	G [inch]	H [inch]	I [inch]	J [inch]
ProPEX LF Brass Commercial Ball Valve (full port) SS Ball and Stem 1" PEX x 1" PEX	LFC4821010SS	1.181	1.618	2.181	4.52	0.748	0.685	6.504	2.181	1.496	3.98
ProPEX LF Brass Commercial Ball Valve (full port) SS Ball and Stem 1 1/4" PEX x 1 1/4" PEX	LFC4821313SS	1.445	1.862	2.388	4.516	0.915	0.821	7.002	3.303	1.831	4.752
ProPEX LF Brass Commercial Ball Valve (full port) SS Ball and Stem 1 1/2" PEX x 1 1/2" PEX	LFC4821515SS	1.705	2.059	3.114	5.584	1.024	0.98	8.368	4.138	2.087	5.469
ProPEX LF Brass Commercial Ball Valve (full port) SS Ball and Stem 2" PEX x 2" PEX	LFC4822020SS	2.146	2.413	3.339	5.584	1.358	1.122	9.021	4.697	2.638	6.705
ProPEX LF Brass Commercial Ball Valve (full port) SS Ball and Stem 1/2" PEX x 1/2" PEX	LFC4825050SS	0.709	1.228	1.679	3.37	0.447	0.465	4.843	2.126	0.959	2.646
ProPEX LF Brass Commercial Ball Valve (full port) SS Ball and Stem 3/4" PEX x 3/4" PEX	LFC4827575SS	0.945	1.358	1.789	3.37	0.634	0.522	5.151	2.423	1.268	3.248

Part name	Part no.	Cv	Weight per UOM [lbs/UOM]	End Type 1	End Type 2
ProPEX LF Brass Commercial Ball Valve (full port) SS Ball and Stem 1" PEX x 1" PEX	LFC4821010SS	29	0.87	ProPEX 1"	ProPEX 1"
ProPEX LF Brass Commercial Ball Valve (full port) SS Ball and Stem 1 1/4" PEX x 1 1/4" PEX	LFC4821313SS	49.1	1.29	ProPEX 1-1/4"	ProPEX 1-1/4"
ProPEX LF Brass Commercial Ball Valve (full port) SS Ball and Stem 1 1/2" PEX x 1 1/2" PEX	LFC4821515SS	58.9	1.9	ProPEX 1-1/2"	ProPEX 1-1/2"
ProPEX LF Brass Commercial Ball Valve (full port) SS Ball and Stem 2" PEX x 2" PEX	LFC4822020SS	139.1	2.97	ProPEX 2"	ProPEX 2"
ProPEX LF Brass Commercial Ball Valve (full port) SS Ball and Stem 1/2" PEX x 1/2" PEX	LFC4825050SS	6.8	0.33	ProPEX 1/2"	ProPEX 1/2"
ProPEX LF Brass Commercial Ball Valve (full port) SS Ball and Stem 3/4" PEX x 3/4" PEX	LFC4827575SS	17	0.45	ProPEX 3/4"	ProPEX 3/4"

Installation

Install valve and stem extension kit according to local building code. Do not dismantle. Refer to the Uponor Piping Pocket Guide or the Uponor Plumbing Design Assistance Manual (PDAM) for additional information.

Related applications

- Hot water distribution
- Hydronic heating and cooling systems
- Hydronic Piping Systems
- Hydronic Radiant Heating and Cooling Systems
- PEX-a Plumbing Systems
- Plumbing Systems
- Pre-Insulated Pipe Systems
- Radiant Heating and Cooling Systems

Codes	Standards	Listings
UPC IBC IRC IPC NPC of Canada UMC IMC	NSF-372 ASTM F877 NSF-359 ASTM F1960 CSA B137.5 NSF-61 NSF-14	cNSFus-pw-G U.P.Code

Footnotes	Contact information	
-	Uponor Inc. 5925 148th Street West Apple Valley, MN 55124 T 800.321.4739 F 952.891.2008	Uponor Ltd. 6510 Kennedy Road Mississauga, ON L5T 2X4 T 888.594.7726 F 800.638.9517