

This document must not be copied without our written permission and the contents thereof must not be imparted to a third party nor be used for any unauthorized purpose, contravention will be prosecuted.

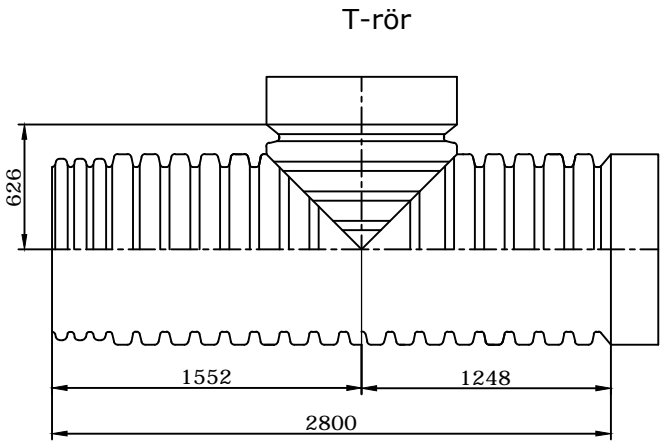
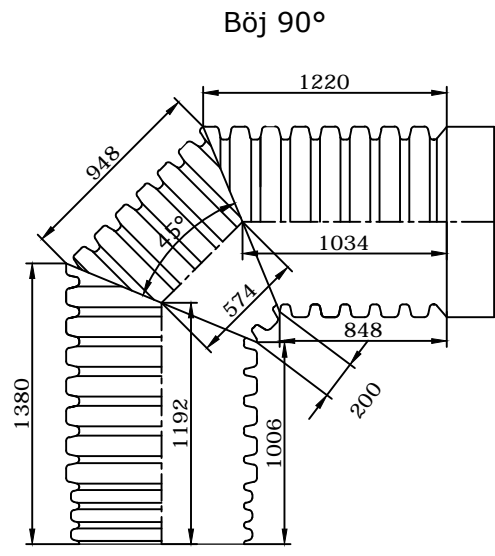
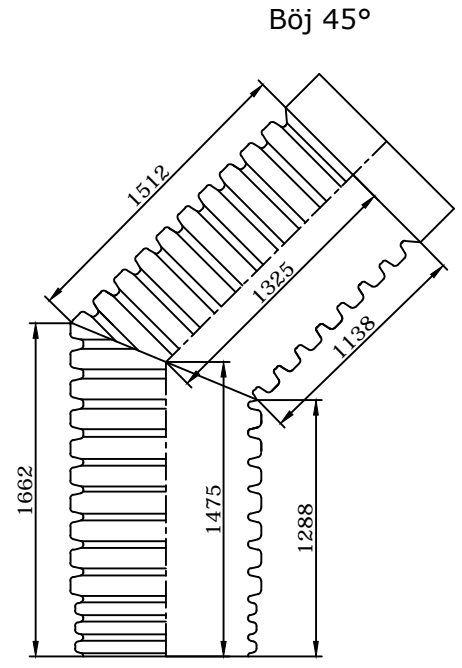
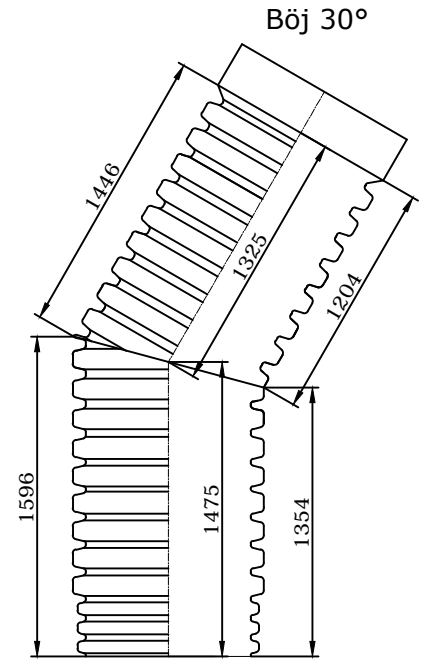
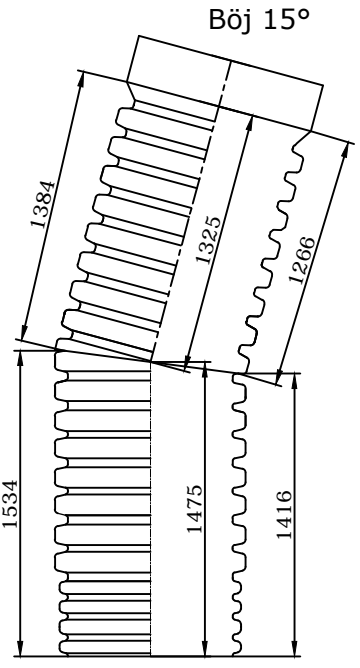

BEND ID 800 15° Uponor no. 1051762
 BEND ID 800 30° Uponor no. 1051763
 BEND ID 800 45° Uponor no. 1051764
 BEND ID 800 90° Uponor no. 1058171
 TEE BRANCH ID 800 Uponor no. 1051759

Change	Location	Change description	Date	Signature
A	B2-B1	NEW UPONOR NO. 1058172 ADDED	27.06.2011	M. HEINONEN
A	B2-B1	PRODUCT NAMES CHANGED	27.06.2011	M. HEINONEN

				PP	
Part	Name	Pcs	Material,color/Number/Tool no/Notes		
Surface	Volume	Weight	Scale	Drawn	27.06.2011 M. HEINONEN
Approvals	Markings		1:1	Check.	27.06.2011 R. JUUTI
Ass. Drw.	Prod. no			Appr.	27.06.2011 T. PARTANEN
			Uponor Uponor Suomi Oy Nastola Finland		Title DW FITTINGS ID 800 BENDS AND TEE BRANCH Tooling
				Drawing no. N01417	