

Blue foam staples

Project Information

| | |
|--------------------------------|-----------------|
| Job name: | Location: |
| Engineer: | Date submitted: |
| Contractor: | Submitted by: |
| Manufacturer's representative: | Approved by: |

Technical data

| | |
|-----------------------|---------------|
| Material | Plastic |
| Subcomponent Material | Polypropylene |

Product information and application use

Use 2" Blue Foam Staples with Uponor PEX Foam Stapler (E6025000) to secure $\frac{3}{8}$ ", $\frac{1}{2}$ ", $\frac{5}{8}$ " and $\frac{3}{4}$ " Uponor PEX or $\frac{1}{2}$ " and $\frac{5}{8}$ " Multi-layer Composite (MLC) tubing to foam board insulation.

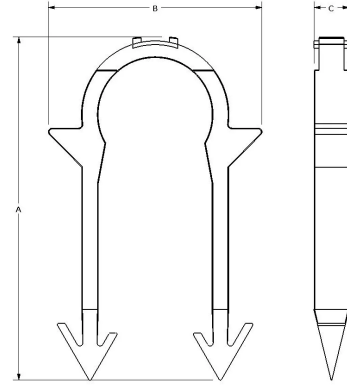

| Part name | Part no. | A [Inch] | B [Inch] | C [Inch] | Weight per UOM [lbs/UOM] |
|--------------------------------|----------|----------|----------|----------|--------------------------|
| 2" Blue Foam Staples, 300/pkg. | A7012000 | 2.189 | 1.46 | 0.234 | 0 |

Installation

Use 2" Blue Foam Staples (A7012000) with Uponor PEX Foam Stapler (E6025000) to secure PEX or MLC tubing to $1\frac{1}{2}$ " or thicker foam board insulation. Refer to the Uponor PEX Foam Stapler Instruction Sheet for more information.

Related applications

- Radiant Heating and Cooling Systems
- Permafrost Protection Systems
- Turf Conditioning Systems

Footnotes

-

Contact information

Uponor Inc.
5925 148th Street West
Apple Valley, MN 55124
T 800.321.4739
F 952.891.2008

Uponor Ltd.
6510 Kennedy Road
Mississauga, ON L5T 2X4
T 888.594.7726
F 800.638.9517