

Blue foam staples

Project Information

Job name:	Location:
Engineer:	Date submitted:
Contractor:	Submitted by:
Manufacturer's representative:	Approved by:

Technical data

Material	Plastic
Subcomponent Material	Polypropylene

Product information and application use

Use 2" Blue Foam Staples with Uponor PEX Foam Stapler (E6025000) to secure $\frac{3}{8}$ ", $\frac{1}{2}$ ", $\frac{5}{8}$ " and $\frac{3}{4}$ " Uponor PEX or $\frac{1}{2}$ " and $\frac{5}{8}$ " Multi-layer Composite (MLC) tubing to foam board insulation.

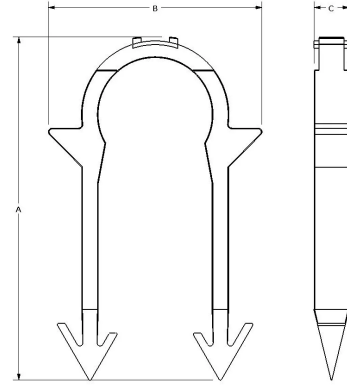

Part name	Part no.	A [Inch]	B [Inch]	C [Inch]	Weight per UOM [lbs/UOM]
2" Blue Foam Staples, 300/pkg.	A7012000	2.189	1.46	0.234	0

Installation

Use 2" Blue Foam Staples (A7012000) with Uponor PEX Foam Stapler (E6025000) to secure PEX or MLC tubing to $1\frac{1}{2}$ " or thicker foam board insulation. Refer to the Uponor PEX Foam Stapler Instruction Sheet for more information.

Related applications

- Radiant Heating and Cooling Systems
- Permafrost Protection Systems
- Turf Conditioning Systems

Footnotes

-

Contact information

Uponor Inc.
5925 148th Street West
Apple Valley, MN 55124
T 800.321.4739
F 952.891.2008

Uponor Ltd.
6510 Kennedy Road
Mississauga, ON L5T 2X4
T 888.594.7726
F 800.638.9517